

CR, CRI, CRN CRE, CRIE, CRNE

Vertical multistage centrifugal pumps
60 Hz



Contents

Mission

3

Product data

Introduction	4
Performance range - CR, CRI, CRN	5
Performance range - CRE, CRIE, CRNE	5
Applications	6
Product range	7
Pump	8
Motor	8
Terminal box positions	8
Ambient temperature	9
Viscosity	9

Product data for E-pumps

Examples of E-pump applications	10
---------------------------------	----

Control of E-pumps

Control options of E-pumps	11
Central management system	11
Control modes for E-pumps	11

Construction

CR(E) 1s, 1, 3, 5, 10, 15 and 20	13
CRI(E), CRN(E) 1s, 1, 3, 5, 10, 15 and 20	13
CR(E) 32, 45, 64 and 90	14
CRN(E) 32, 45, 64 and 90	14

Type keys and codes

Type keys	15
Codes	15

Operating and inlet pressure

Maximum operating pressure and temperature range	16
Operating range of the shaft seal	17
Maximum inlet pressure	18

Selection and sizing

Selection of pumps	19
How to read the curve charts	23
Guidelines to performance curves	23

Performance curves/ Technical data

CR, CRI, CRN 1s	24
CR(E), CRI(E), CRN(E) 1	28
CR(E), CRI(E), CRN(E) 3	32
CR(E), CRI(E), CRN(E) 5	36
CR(E), CRI(E), CRN(E) 10	40
CR(E), CRI(E), CRN(E) 15	44
CR(E), CRI(E), CRN(E) 20	48
CR(E), CRN(E) 32	52
CR(E), CRN(E) 45	55
CR(E), CRN(E) 64	58
CR, CRN 90	61

Motor data

TEFC motors	64
MLE motors	65
ODP motors	65

Pumped liquids

Pumped liquids	66
List of pumped liquids	66

Accessories

Pipework connection	69
Sensors for CRE, CRIE, CRNE	74
Gauges for CRE, CRIE, CRNE	74

Variants

Lists of variants - on request	75
Motors	75
Connections and other variants	75
Shaft seals	75
Pumps	75

Submittal data sheet

76

Quotation text

77

Further product documentation

Sources of product documentation	78
WinCAPS®	78
WebCAPS®	79

Mission

- to successfully develop, produce, and sell high quality pumps and pumping systems worldwide, contributing to a better quality of life and healthier environment



GBJ - Bjerringbro, Denmark



GMU - Fresno, California



GPU - Olathe, Kansas



GMX - Monterrey, Mexico



GPA - Allentown, Pennsylvania



GCA - Oakville, Ontario

- One of the 3 largest pump companies in the world
- World headquarters in Denmark
- North American headquarters in Kansas City - Manufacturing in Fresno, California
- 60 companies in 40 countries
- More than 10 million pumps produced annually worldwide
- North American companies operating in USA, Canada and Mexico
- Continuous reinvestment in growth and development enables the company to **BE** responsible, **THINK** ahead, and **INNOVATE**

Introduction

This data booklet deals with CR, CRI and CRN as well as CRE, CRIE and CRNE pumps.



Fig. 1 CR, CRI and CRN pumps

CR, CRI, CRN pumps are vertical multistage centrifugal pumps. The in-line design enables the pump to be installed in a horizontal one-pipe system where the suction and discharge ports are in the same horizontal plane and have the same pipe dimensions. This design provides a more compact pump design and pipework.

Grundfos CR pumps come with various pump sizes and various numbers of stages to provide the flow and the pressure required.

CR pumps are suitable for a variety of applications from pumping of potable water to pumping of chemicals. The pumps are therefore used in a wide variety of pumping systems where the performance and material of the pump meet specific demands.

The CR pumps consist of two main components: the motor and the pump unit. The motor on a CR pump is a heavy-duty Grundfos specified motor.

The pump unit consists of optimized hydraulics, various types of connections, an outer sleeve, a top and various other parts.

CR pumps are available in various material versions according to the pumped liquid.

CRE, CRIE, CRNE pumps



Fig. 2 CRE, CRIE and CRNE pumps

CRE, CRIE, CRNE pumps are built on the basis of CR, CRI, CRN pumps.

CRE, CRIE, CRNE pumps belong to the so-called E-pump family and are referred to as E-pumps.

The difference between the CR and the CRE pump range is the motor. CRE, CRIE, CRNE pumps are fitted with an E-motor, i.e. a motor with built-in frequency control.

The motor of the CRE pump is a Grundfos MLE motor.

Frequency control enables continuously variable control of motor speed, which makes it possible to set the pump to operation at any duty point. The aim of continuously variable control of the motor speed is to adjust the performance to a given requirement.

CRE, CRIE and CRNE pumps are available with an integrated pressure sensor connected to the frequency control.

The pump materials are the same as those of the CR, CRI, CRN pump range.

Selection a CRE pump

Select a CRE pump if:

- controlled operation is required, i.e. consumption fluctuates;
- constant pressure is required,
- communication with the pump is required.

Adaptation of performance through frequency-controlled speed control offers obvious advantages:

- Energy savings.
- Increased comfort.
- Control and monitoring of the pump performance.

Performance range - CR, CRI, CRN

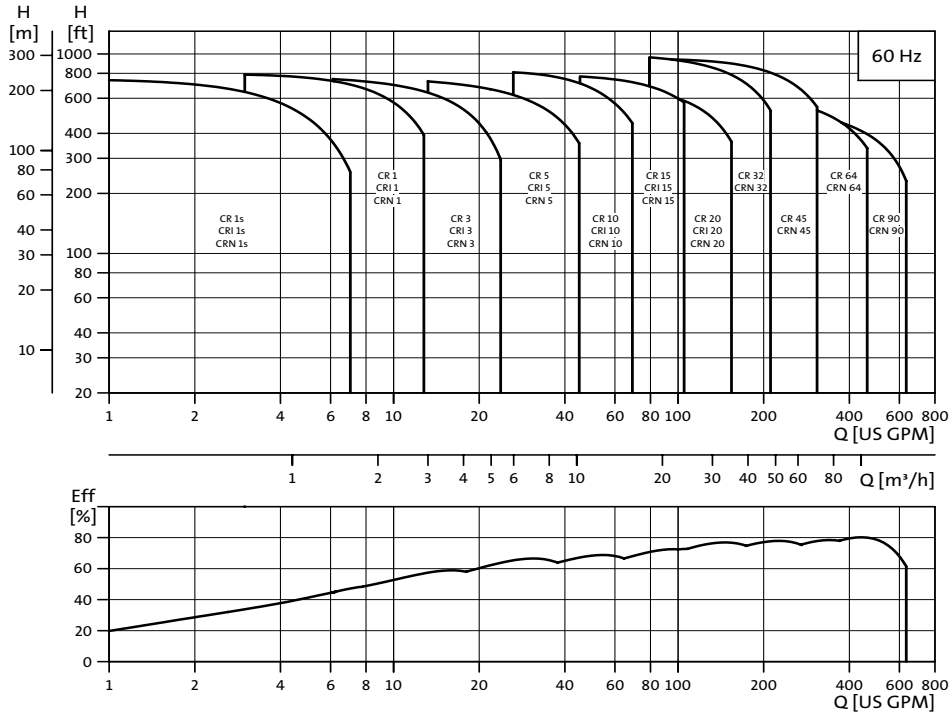

TM02 5518 5103

Performance range - CRE, CRIE, CRNE

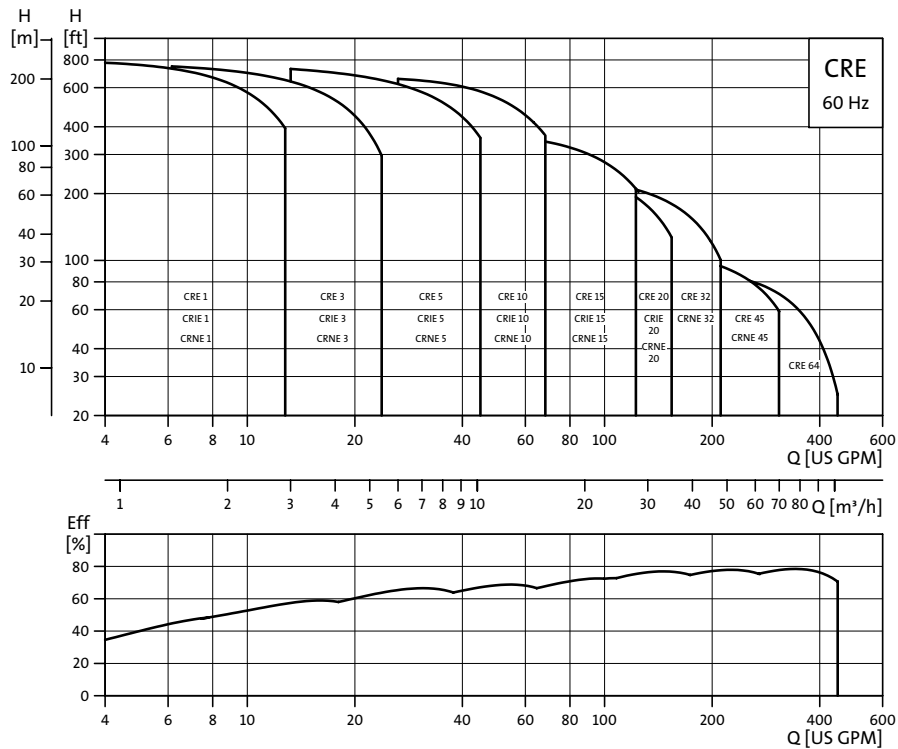

TM02 8094 4603

Applications

Application	CR, CRI	CRN	CRE, CRNE
Water supply			
Filtration and transfer at waterworks	●	○	●
Distribution from waterworks	●	○	●
Pressure boosting in mains	●	○	●
Pressure boosting in high-rise buildings, hotels, etc.	●	○	●
Pressure boosting for industrial water supply	●	○	●
Industry			
Pressure boosting in...			
process water systems	●	●	●
washing and cleaning systems	●	●	●
vehicle washing tunnels	●	○	●
fire fighting systems	●		
Liquid transfer in...			
cooling and air-conditioning systems (refrigerants)	●	○	●
boiler feed and condensate systems	●	○	●
machine tools (cooling lubricants)	●	●	●
aquafarming★	●	○	
Transfer of...			
oils and alcohols	●	●	●
acids and alkalis★		●	●
glycol and coolants	●		●
Water treatment			
Ultra-filtration systems		●	●
Reverse osmosis systems★		●	●
Softening, ion exchange, demineralizing systems		●	●
Distillation systems		●	●
Separators	●	●	●
Swimming pools★		●	●
Irrigation			
Field irrigation (flooding)	●	○	
Sprinkler irrigation	●	○	●
Drip-feed irrigation	●	○	

● Recommended version.

○ Alternative version.

★ CRT, CRTE version available. For further information about CRT, CRTE pumps see, "Pumped liquids" page 66 or related CRT, CRTE data booklet.

Product range

Range	CR 1s	CR, CRE 1	CR, CRE 3	CR, CRE 5	CR, CRE 10	CR, CRE 15	CR, CRE 20	CR, CRE 32	CR, CRE 45	CR, CRE 64	CR, CRE 90
Nominal flow rate [US GPM]	4.5	8.5	15	30	55	95	110	140	220	340	440
Temperature range [°F]				-4 to +250					-22 to +250		
Temperature range [°F] – on request				-40 to +356					-40 to +356		
Max. working pressure [psi]	360	360	360	360	360	360	360	435	435	360	360
Max. working pressure [psi] – on request	-	725	725	725	725	725	725	580	580	580	580
Max. pump efficiency [%]	35	49	59	67	70	72	72	76	78	79	80
CR pumps											
CR: Flow range [US GPM]	0.5 - 5.7	1 - 12.8	1.5 - 23.8	3 - 45	5.5 - 70	9.5 - 125	11 - 155	14 - 210	22 - 310	34 - 450	44 - 630
CR: Max. pump pressure (H[ft])	760	790	790	780	865	800	700	995	940	565	595
CR: Motor power [Hp]	1/3 - 2	1/3 - 3	1/3 - 5	3/4 - 7 1/2	3/4 - 15	2 - 25	3 - 25	3 - 40	7 1/2 - 60	7 1/2 - 50	15 - 60
CRE pumps											
CRE: Flow range [US GPM]	-	0 - 12.8	0 - 23.8	0 - 45	0 - 70	0 - 125	0 - 155	0 - 210	0 - 310	0 - 450	-
CRE: Max. pump pressure (H[ft])	-	790	790	780	665	390	270	240	120	100	-
CRE: Motor power [Hp]	-	1/3 - 3	1/3 - 5	3/4 - 7 1/2	3/4 - 10	2 - 10	3 - 10	3 - 10	7 1/2	7 1/2	-
Version											
CR, CRE: Cast iron and stainless steel AISI 304	●	●	●	●	●	●	●	●	●	●	●
CR1, CRIE: Stainless steel AISI 304	●	●	●	●	●	●	●	-	-	-	-
CRN, CRNE: Stainless steel AISI 316	●	●	●	●	●	●	●	●	●	●	●
CRT, CRTE: Titanium	-	●★	●★	●★	●★	●★	-	-	-	-	-
CR, CRE pipe connection											
Oval flange (NPT)	1"	1"	1"	1 1/4"	2"	2"	2"	-	-	-	-
Oval flange (NPT) - on request	1 1/4"	1 1/4"	1 1/4"	1"	1 1/2"	-	-	-	-	-	-
ANSI flange size	1 1/4"	1 1/4"	1 1/4"	1 1/4"	2"	2"	2"	2 1/2"	3"	4"	4"
ANSI flange size - on request	-	-	-	-	-	-	-	3"	4"	5"	5"
ANSI flange class	250 lb.	250 lb.	250 lb.	250 lb.	250 lb.	250 lb.	250 lb.	125/ 250 lb.	125/ 250 lb.	125/ 250 lb.	125/ 250 lb.
CRI, CRIE pipe connection											
Oval flange (NPT)	1"	1"	1"	1 1/4"	2"	2"	2"	-	-	-	-
Oval flange (NPT) - on request	1 1/4"	1 1/4"	1 1/4"	1"	1 1/2"	-	-	-	-	-	-
ANSI flange size	1 1/4"	1 1/4"	1 1/4"	1 1/4"	2"	2"	2"	-	-	-	-
ANSI flange class	300 lb.	300 lb.	300 lb.	300 lb.	300 lb.	300 lb.	300 lb.	-	-	-	-
Clamp coupling (NPT) - on request	1", 1 1/4"	1", 1 1/4"	1", 1 1/4"	1", 1 1/4"	1 1/2", 2"	1 1/2", 2"	2", 2 1/2"	-	-	-	-
Union (NPT ext. thread) - on request	2"	2"	2"	2"	-	-	-	-	-	-	-
CRN, CRNE pipe connection											
PJE (Vitaallic)	1 1/4"	1 1/4"	1 1/4"	1 1/4"	2"	2"	2"	-	-	-	-
PJE (Vitaallic) - on request	-	-	-	-	-	-	-	3"	4"	4"	4"
ANSI flange size	1 1/4"	1 1/4"	1 1/4"	1 1/4"	2"	2"	2"	2 1/2"	3"	4"	4"
ANSI flange size - on request	-	-	-	-	-	-	-	3"	-	-	-
ANSI flange class	300 lb.	300 lb.	300 lb.	300 lb.	300 lb.	300 lb.	300 lb.	150/ 300 lb.	150/ 300 lb.	150/ 300 lb.	150/ 300 lb.
Clamp coupling (NPT) - on request	1", 1 1/4"	1", 1 1/4"	1", 1 1/4"	1", 1 1/4"	1 1/2", 2"	2", 2 1/2"	2", 2 1/2"	-	-	-	-
Union (NPT ext. thread) - on request	2"	2"	2"	2"	-	-	-	-	-	-	-
CRT pipe connection											
PJE coupling (Vitaallic)	-	1 1/4"	1 1/4"	1 1/4"	2"	2"	-	-	-	-	-
ANSI flange size - on request	-	-	-	-	2"	2"	-	-	-	-	-

● :Available

★ :CRT 2, 4, 8, 16

Pump

The CR and CRE pump is a non-self-priming, vertical multistage centrifugal pump. The pumps are available with a Grundfos standard motor (CR pumps) or a frequency-controlled motor (CRE pumps).

The pump consists of a base and a pump head. The chamber stack and the outer sleeve are secured between the pump head and the base by means of staybolts. The base has suction and discharge ports on the same level (in-line).

All pumps are equipped with a maintenance-free mechanical shaft seal of the cartridge type.

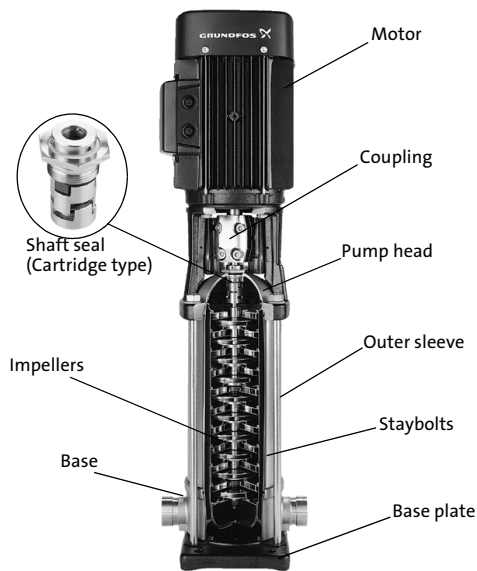

CR5357 - CR33395

Fig. 3 CR pump

Motor

Grundfos standard motors - ML and Baldor® motors

CR, CRI and CRN pumps are fitted with a Grundfos specified motor. The motors are all heavy-duty 2-pole, NEMA C-face motors.

Frequency-controlled motors - MLE motors

CRE, CRIE and CRNE pumps are fitted with a totally enclosed, fan-cooled, 2-pole frequency-controlled motor.

From 0.5 Hp to 1.5 Hp Grundfos offers CRE pumps fitted with single-phase MLE motors (1 x 208-230 V).

From 1.0 Hp to 10 Hp Grundfos offers CRE pumps fitted with three-phase MLE motors (3 x 460-480 V).

Electrical data

Mounting designation	NEMA
Insulation class	F & B
Efficiency class*	Standard efficiency Energy efficient / EPAct - on request Premium efficiency - on request
Enclosure class	TEFC - Totally Enclosed Fan Cooled (Grundfos standard) ODP - Open Drip Proof - on request
60 Hz Standard voltages	1 x 115/208-230 V 3 x 208-230/460 V 3 x 575 V

The motors are rated for:

Approvals



* 1, 1.5 and 2 HP ML motors are premium efficiency as standard

Optional motors

The Grundfos standard range of motors covers a wide variety of application demands. However, for special applications or operating conditions, custom-built motor solutions can be provided.

For special applications or operating conditions, Grundfos offers custom-built motors such as:

- explosion proof motors,
- motors with anti-condensation heating unit,
- low-noise motors,
- energy efficient and premium efficiency motors,
- motors with thermal protection.

Motor protection

Single-phase Grundfos motors have a built-in thermal overload switch.

Three-phase motors **must** be connected to a motor starter in accordance with local regulations.

Terminal box positions

As standard the terminal box is mounted on the suction side of the pump.

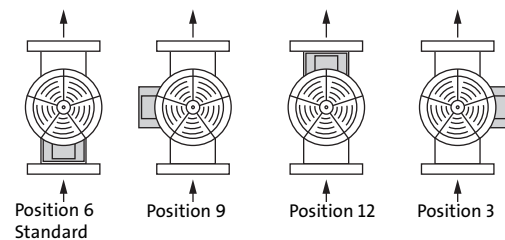

Fig. 4 Terminal box positions

TM02.18.05.2001

Ambient temperature

Ambient temperature: Maximum +104°F.

If the ambient temperature exceeds +104°F or if the motor is located 3280 feet above sea level or higher, the motor output (P2) must be reduced due to the low cooling effect of the air. In such cases, it may be necessary to use a motor with a higher output.

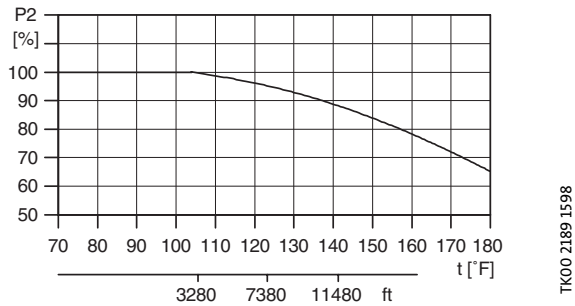

Fig. 5 Relationship between motor output (P2) and ambient temperature

Viscosity

The pumping of liquids with densities or kinematic viscosities higher than those of water will cause a considerable pressure drop, a drop in the hydraulic performance and a rise in the power consumption.

In such situations the pump should be equipped with a larger motor. If in doubt, contact Grundfos.

Examples of E-pump applications

CRE, CRIE and CRNE pumps are the ideal solution in a number of applications characterized by a need for variable flow at constant pressure. The pumps are suited for water supply systems and pressure boosting, but also industrial applications.

Depending on the nature of the application, the pumps offer energy-savings, increased comfort or improved processing.

E-pumps in the service of industry

Industry uses a large number of pumps in many different applications. Demands on pumps in terms of pump performance and mode of operation make speed control a must in many applications.

Below are mentioned some of the applications in which E-pumps are often used.

Constant pressure

- Water supply,
- Washing and cleaning systems,
- Distribution from waterworks,
- Humidifying systems,
- Water treatment systems,
- Process boosting systems, etc.

Example: Within industrial water supply, E-pumps with integrated pressure sensors are used to ensure a constant pressure in the piping network. From the sensor, the E-pump receives inputs about changes of pressure as a result of changes in the consumption. The E-pump responds to the input by adjusting the flow until the pressure is equalized. The constant pressure is stabilized once more on the basis of a preset setpoint.

Constant temperature

- Air-conditioning systems at industrial plants,
- Industrial cooling systems,
- Industrial freezing systems,
- Casting and moulding tools, etc.

Example: In industrial freezing systems, E-pumps with temperature sensor increase comfort and lower operating costs compared with pumps without a temperature sensor.

An E-pump continuously adapts its performance to the changing demands reflected in the differences in temperature of the liquid circulating in the freezing system. Thus, the lower the demand for cooling, the smaller the quantity of liquid circulated in the system and vice versa.

Constant flow

- Steam boiler systems,
- Condensate systems,
- Sprinkler irrigation systems,
- Chemical industry, etc.

Example: In a steam boiler, it is important to be able to monitor and control pump operation to maintain a constant level of water in the boiler.

By using an E-pump with level sensor mounted in the boiler, it is possible to maintain a constant water level. A constant water level ensures optimum and cost-efficient operation as a result of a stable steam production.

Dosing

- Chemical industry (i.e. control of pH-values),
- Petrochemical industry,
- Paint industry
- Degreasing systems,
- Bleaching systems, etc.

Example: In the petrochemical industry, E-pumps with pressure sensors are used as dosing pumps. The E-pumps help to ensure that the correct mixture ratio is achieved when more liquids are combined.

E-pumps functioning as dosing pumps improve processing and offer energy-savings.

E-pumps in commercial building services

Commercial building services use E-pumps to maintain a constant pressure or a constant temperature based on a variable flow.

E-pumps are used in applications such as

Constant pressure

- Water supply in high-rise buildings i.e. office buildings, hotels, etc.

Example: E-pumps with pressure sensors are used for water supply in high-rise buildings to ensure a constant pressure even at the highest draw-off point. As the consumption pattern and by that the pressure changes during the day, the E-pump continuously adapts its performance until the pressure is equalized.

Constant temperature

- Air-conditioning systems in hotels, schools,
- Building cooling systems, etc.

Example: E-pumps are an excellent solution in buildings where constant temperature is essential. E-pumps keep the temperature constant in air-conditioned high-rise glass buildings, irrespective of the seasonal fluctuations of the out-door temperature, and various heat impacts inside the building.

Control options of E-pumps

Communication with CRE, CRIE, CRNE pumps is possible by means of

- a central management system,
- remote control (Grundfos R100) or
- a control panel.

The purpose of controlling an E-pump is to monitor and control the pressure, temperature, flow and liquid level of the system.

Central management system

Communication with the E-pump is possible even though the operator is not present near the E-pump. Communication is enabled by having connected the E-pump to a central management system allowing the operator to monitor and change control modes and setpoint settings of the E-pump.

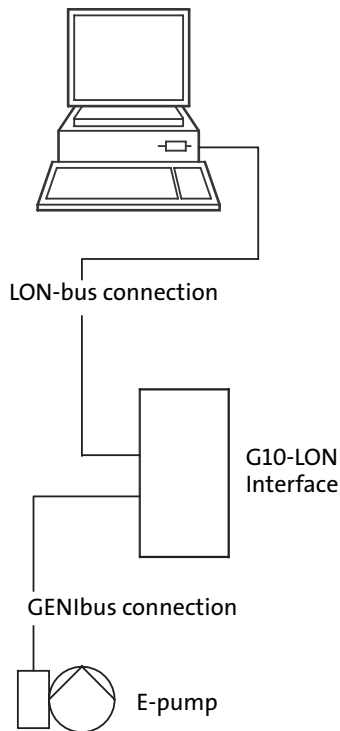

Fig. 6 Structure of a central management system

TM06592 1103

Remote control

The R100 remote control produced by Grundfos is available as an accessory.

The operator communicates with the E-pump by pointing the IR-signal transmitter at the control panel of the E-pump terminal box.

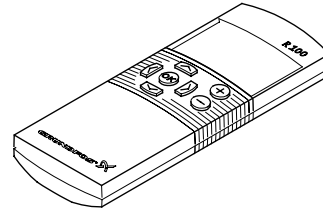

TM00 4498 2802

Fig. 7 R100 remote control

On the R100 display it is possible to monitor and change control modes and settings of the E-pump.

Control panel

The control panel of the E-pump terminal box makes it possible to change the setpoint settings manually.

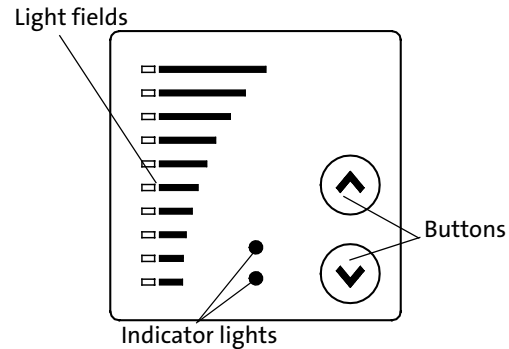

TM00 7600 1196

Fig. 8 Control panel on CRE pump

Control modes for E-pumps

Grundfos offers CRE, CRIE and CRNE pumps in two different variants:

- CRE, CRIE and CRNE with integrated pressure sensor
- CRE, CRIE and CRNE without sensor.

CRE, CRIE, CRNE with integrated pressure sensor

CRE, CRIE and CRNE pumps with integrated pressure sensors are suitable for applications where you want to control the pressure after the pump, irrespective of the flow. For further information, see the section "Examples of E-pump applications" on page 10. Signals of pressure changes in the piping system are transmitted continuously from the sensor to the pump.

The pump responds to the signals by adjusting its performance up or down to compensate for the pressure difference between the actual and the desired pressure. As this adjustment is a continuous process, a constant pressure is maintained in the piping system.



Fig. 9 CRE, CRIE and CRNE pumps

TM02 7398 3403

A CRE, CRIE or CRNE pump with integrated pressure sensor facilitates installation and commissioning. CRE, CRIE and CRNE pumps with integrated pressure sensor can be set to:

- constant-pressure mode (factory setting) or
- constant-curve mode.

In **constant-pressure** mode, the pump maintains a preset pressure after the pump, irrespective of the flow, see figure below.

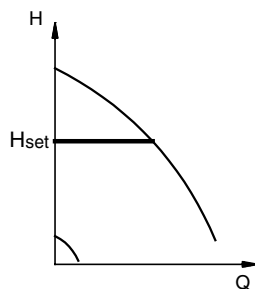

Fig. 10 Constant pressure mode

TM00 9322 4796

In **constant-curve** mode, the pump is not controlled. It can be set to pump according to a preset pump characteristic within the range from min. curve to max. curve, see figure below.

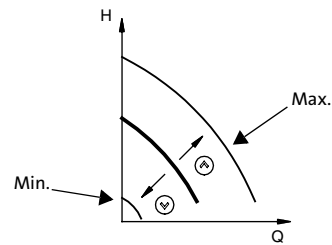

Fig. 11 Constant curve mode

TM00 9323 4796

CRE, CRIE and CRNE without sensor

CRE, CRIE and CRNE pumps without sensors are suitable for applications where

- uncontrolled operation is required
- you want to fit another sensor later in order to control the flow, temperature, differential temperature, liquid level, pH value, etc at some arbitrary point in the system.

CRE, CRIE and CRNE pumps without sensor can be set to:

- controlled-operation mode or
- uncontrolled-operation mode (factory-setting).

In **controlled-operation** mode, the pump adjusts its performance to the desired setpoint, see figure below.

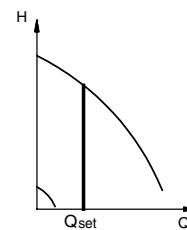

Fig. 12 Constant flow mode

TM02 7264 2803

In **uncontrolled-operation** mode, the pump operates according to the constant curve set, see figure below.

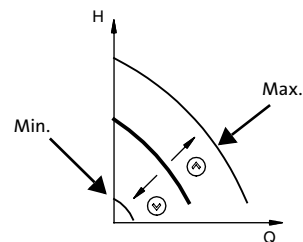

Fig. 13 Constant curve mode

TM00 9323 4796

CRE, CRIE and CRNE pumps can be fitted with sensor types listed on page 74.

CR(E) 1s, 1, 3, 5, 10, 15 and 20



TM02.1198.0601 - CR7371 - CR7379

Sectional drawing

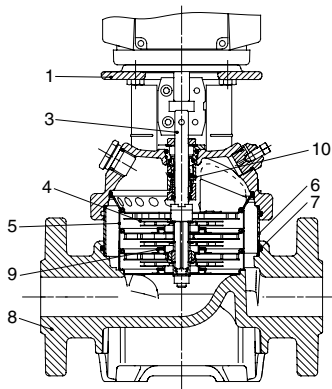

TM02.1194.1403

Materials: CR(E)

Pos.	Designation	Materials	AISI/ASTM
1	Pump head	Cast iron	A 48-30 B
3	Shaft	Stainless steel	AISI 316 ¹⁾ AISI 431 ²⁾
4	Impeller	Stainless steel	AISI 304
5	Chamber	Stainless steel	AISI 304
6	Outer sleeve	Stainless steel	AISI 304
7	O-ring for outer sleeve	EPDM or FKM	
8	Base	Cast iron	A 48-30 B
9	Neck ring	PTFE	
10	Shaft seal	Cartridge type	
	Bearing rings	Silicon carbide	
	Rubber parts	EPDM or FKM	

¹⁾ CR(E) 1s, 1, 3, 5

²⁾ CR(E) 10, 15, 20

³⁾ Stainless steel available on request.

⁴⁾ CF 8M is cast equivalent of AISI 316 stainless steel.

⁵⁾ CRI(E)/CRN(E) 1s, 1, 3, 5

⁶⁾ CRN(E) 10, 15, 20

⁷⁾ CRI(E) 10, 15, 20

CRI(E), CRN(E) 1s, 1, 3, 5, 10, 15 and 20



TM02.1808.2001 - GR7373 - GR7375

Sectional drawing

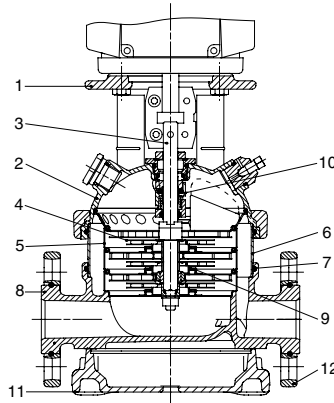

TM03.2156.3805

Materials: CRI(E), CRN(E)

Pos.	Designation	Materials	AISI/ASTM
1	Pump head	Cast iron ³⁾	A 48-30 B
2	Pump head cover	Stainless steel	CF 8M ⁴⁾
3	Shaft	Stainless steel	AISI 316 ⁵⁾ AISI 329 ⁶⁾ AISI 431 ⁷⁾
8	Base	Stainless steel	CF 8M ⁴⁾
9	Neck ring	PTFE	
10	Shaft seal	Cartridge type	
11	Base plate	Cast iron ³⁾	A 48-30 B
	Bearing rings	Silicon carbide	
	Rubber parts	EPDM or FKM	
CRI(E)			
4	Impeller	Stainless steel	AISI 304
5	Chamber	Stainless steel	AISI 304
6	Outer sleeve	Stainless steel	AISI 304
7	O-ring for outer sleeve	EPDM or FKM	
12	FGJ flange ring	Ductile iron ³⁾	A 65-45-12
CRN(E)			
4	Impeller	Stainless steel	AISI 316
5	Chamber	Stainless steel	AISI 316
6	Outer sleeve	Stainless steel	AISI 316
7	O-ring for outer sleeve	EPDM or FKM	
12	FGJ flange ring	Ductile iron ³⁾	A 65-45-12

CR(E) 32, 45, 64 and 90



TM01 2150 1298 - CR 8073

CRN(E) 32, 45, 64 and 90



TM02 7199 3403

Sectional drawing

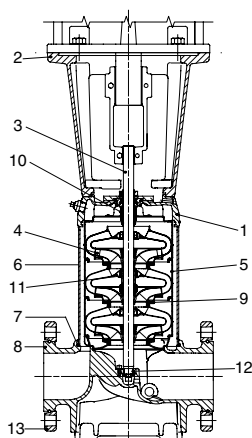

TM03 2157 3805

Sectional drawing

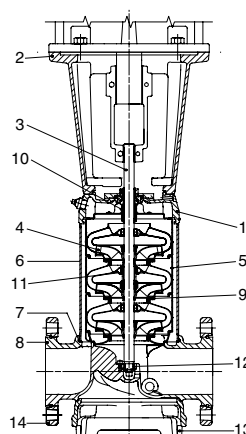

TM03 2158 3805

Materials: CR(E)

Pos.	Designation	Materials	AISI/ASTM
1	Pump head	Ductile iron	A 65-45-12
2	Motor stool	Cast iron	A 48-30 B
3	Shaft	Stainless steel	AISI 431
4	Impeller	Stainless steel	AISI 304
5	Chamber	Stainless steel	AISI 304
6	Outer sleeve	Stainless steel	AISI 304
7	O-ring for outer sleeve	EPDM or FKM	
8	Base	Ductile iron	A 65-45-12
9	Neck ring	Acoflon 215	
10	Shaft seal	Cartridge type	
11	Bearing ring	Bronze	
12	Bottom bearing ring	Tungsten carbide/ Tungsten carbide	
13	Flange ring	Ductile iron ²⁾	A 65-45-12
	Rubber parts	EPDM or FKM	

Materials: CRN(E)

Pos.	Designation	Materials	AISI/ASTM
1	Pump head	Stainless steel	CF 8M ¹⁾
2	Motor stool	Cast iron	A 48-30 B
3	Shaft	Stainless steel	SAF 2205
4	Impeller	Stainless steel	AISI 316
5	Chamber	Stainless steel	AISI 316
6	Outer sleeve	Stainless steel	AISI 316
7	O-ring for outer sleeve	EPDM or FKM	
8	Base	Stainless steel	CF 8M ¹⁾
9	Neck ring	Acoflon 215	
10	Shaft seal	Cartridge type	
11	Bearing ring	Carbon-graphite filled PTFE	
12	Bottom bearing ring	Tungsten carbide/ Tungsten carbide	
13	Base plate	Ductile iron ²⁾	A 65-45-12
14	Flange ring	Ductile iron ²⁾	A 65-45-12
	Rubber parts	EPDM or FKM	

¹⁾ CF 8M is cast equivalent of AISI 316 stainless steel.

²⁾ Stainless steel available on request.

Type keys

CR(E), CRI(E), CRN(E)

Example	CR	E	32	(s)	-4	-2	-A	-G	-G	-E	-HQQE
Type range: CR, CRI, CRN											
Pump with integrated frequency control											
Nominal flow rate [m ³ /h]											
All impellers with reduced diameter (applies only to CR, CRI, CRN 1s)											
Number of impellers											
Number of reduced diameter impellers (CR(E), CRN(E) 32, 45, 64, 90)											
Code for pump version											
Code for pipe connection											
Code for materials											
Code for rubber parts											
Code for shaft seal											

Codes

Example	A	-F	-A	-E	-H	QQ	E
Pump version							
A Basic version ¹⁾							
B Oversize motor							
E Certificate/approval							
F CR pump for high temperatures (air-cooled top assembly)							
H Horizontal version							
HS High-pressure pump with high speed MLE motor							
I Different pressure rating							
J Pump with different max speed							
K Pump with low NPSH							
M Magnetic drive							
N Fitted with sensor							
P Undersize motor							
R Horizontal version with bearing bracket							
SF High pressure pump							
T Over size motor (two flange sizes bigger)							
U NEMA version ¹⁾							
X Special version							
Pipe connection							
A Oval flange							
B NPT thread							
CA FlexiClamp (CRI(E), CRN(E) 1, 3, 5, 10, 15, 20)							
CX Triclamp (CRI(E), CRN(E) 1, 3, 5, 10, 15, 20)							
F DIN flange							
G ANSI flange							
J JIS flange							
N Changed diameter of ports							
P PJE coupling							
X Special version							

Example	A	-F	-A	-E	-H	QQ	E
Materials							
A Basic version							
D Carbon-graphite filled PTFE (bearings)							
G Wetted parts AISI 316							
GI All parts stainless steel, wetted parts AISI 316							
I Wetted parts AISI 304							
II All parts stainless steel, wetted parts AISI 304							
K Bronze (bearings)							
S SiC bearings + PTFE neck rings							
X Special version							
Code for rubber parts							
E EPDM							
F FXM							
K FFKM							
V FKM							
Shaft seal							
A O-ring seal with fixed driver							
B Rubber bellows seal							
E Cartridge seal with O-ring							
H Balanced cartridge seal with O-ring							
K Metal bellows cartridge seal							
O Double seal, back-to-back							
P Double seal, tandem							
X Special version							
B Carbon, synthetic resin-impregnated							
H Cemented tungsten carbide, embedded (hybrid)							
Q Silicon carbide							
U Cemented tungsten carbide							
X Other ceramics							
E EPDM							
F FXM							
K FFKM							
V FKM							

¹⁾ In August 2003 the NEMA version pump code was discontinued for all material numbers created by Grundfos manufacturing companies in North America. The NEMA version pump code will still remain in effect for existing material numbers. NEMA version pumps built in North America after this change will have either an A or U as the pump version code depending on the date the material number was created.

Maximum operating pressure and temperature range

	Oval flange		ANSI, Clamp, PJE	
	Max. permissible operating pressure	Liquid temperature range	Max. permissible operating pressure	Liquid temperature range
CR, CRI, CRN 1s	232 [psi]	-4°F to +248°F	362 [psi]	-4°F to +248°F
CR(E), CRI(E), CRN(E) 1	232 [psi]	-4°F to +248°F	362 [psi]	-4°F to +248°F
CR(E), CRI(E), CRN(E) 3	232 [psi]	-4°F to +248°F	362 [psi]	-4°F to +248°F
CR(E), CRI(E), CRN(E) 5	232 [psi]	-4°F to +248°F	362 [psi]	-4°F to +248°F
CR(E) 10-1 → CR(E) 10-6	145 [psi]	-4°F to +248°F	-	-
CRI(E), CRN(E) 10-1 → CRI(E), CRN(E) 10-10	232 [psi]	-4°F to +248°F	-	-
CR(E), CRI(E), CRN(E) 10-1 → CR(E), CRI(E), CRN(E) 10-10	-	-	232 [psi]	-4°F to +248°F
CR(E), CRI(E), CRN(E) 10-12 → CR(E), CRI(E), CRN(E) 10-17	-	-	362 [psi]	-4°F to +248°F
CR(E) 15-1 → CR(E) 15-5	145 [psi]	-4°F to +248°F	-	-
CRI(E), CRN(E) 15-1 → CRI(E), CRN(E) 15-8	232 [psi]	-4°F to +248°F	-	-
CR(E), CRI(E), CRN(E) 15-1 → CR(E), CRI(E), CRN(E) 15-8	-	-	232 [psi]	-4°F to +248°F
CR(E), CRI(E), CRN(E) 15-9 → CR(E), CRI(E), CRN(E) 15-12	-	-	362 [psi]	-4°F to +248°F
CR(E) 20-1 → CR(E) 20-5	145 [psi]	-4°F to +248°F	-	-
CRI(E), CRN(E) 20-1 → CRI(E), CRN(E) 20-7	232 [psi]	-4°F to +248°F	-	-
CR(E), CRI(E), CRN(E) 20-1 → CR(E), CRI(E), CRN(E) 20-7	-	-	232 [psi]	-4°F to +248°F
CR(E), CRI(E), CRN(E) 20-8 → CR(E), CRI(E), CRN(E) 20-10	-	-	362 [psi]	-4°F to +248°F
CR(E), CRN(E) 32-1-1 → CR(E), CRN(E) 32-5	-	-	232 [psi]	-22°F to +248°F
CR, CRN 32-6-2 → CR, CRN 32-8	-	-	362 [psi]	-22°F to +248°F
CR, CRN 32-9-2 → CR, CRN 32-11-2	-	-	435 [psi]	-22°F to +248°F
CR(E), CRN(E) 45-1-1 → CR(E), CRN(E) 45-4-2	-	-	232 [psi]	-22°F to +248°F
CR(E), CRN(E) 45-4-1 → CR(E), CRN(E) 45-6	-	-	362 [psi]	-22°F to +248°F
CRI, CRN 45-7-2 → CR, CRN 45-8-1	-	-	435 [psi]	-22°F to +248°F
CR(E), CRN(E) 64-1-1 → CR(E), CRN(E) 64-3	-	-	232 [psi]	-22°F to +248°F
CR, CRN 64-4-2 → CR, CRN 64-5-2	-	-	362 [psi]	-22°F to +248°F
CR, CRN 90-1-1 → CR, CRN 90-3	-	-	232 [psi]	-22°F to +248°F
CR, CRN 90-4-2 → CR, CRN 90-4-1	-	-	362 [psi]	-22°F to +248°F

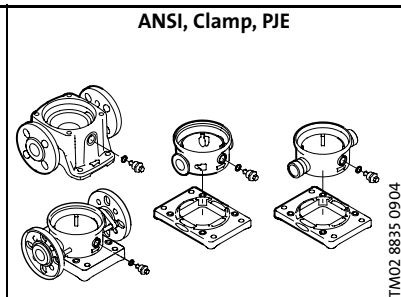
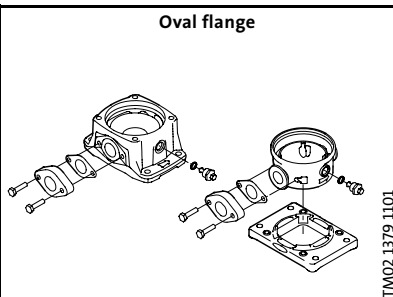

Operating range of the shaft seal

The operating range of the shaft seal depends on operating pressure, pump type, type of shaft seal and liquid temperature. The following curves apply to clean water and water with anti-freeze liquids. For selecting the right shaft seal, see 'List of pumped liquids' page 66.

CR 1s - CR 20

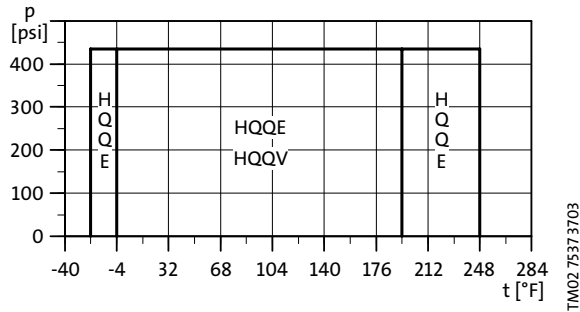

Fig. 14 Operating range of standard shaft seals for CR 1s - CR 20

CR 32 - CR 90

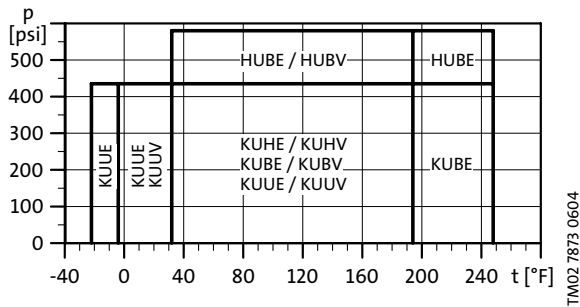

Fig. 15 Operating range of standard shaft seals for CR 32 - CR 90

Shaft seal	Description	Max. temp. range [°F]
HQQE	O-ring (cartridge) (balanced seal), SiC/SiC, EPDM	-22°F to +248°F
HQQV	O-ring (cartridge) (balanced seal), SiC/SiC, FKM	-4°F to +194°F
HUBE	O-ring (cartridge) (balanced seal), TC/carbon, EPDM	+32°F to +248°F
HUBV	O-ring (cartridge) (balanced seal), TC/carbon, FKM	+32°F to +194°F
KUBE	Bellows, metal (cartridge), TC/carbon, EPDM	+32°F to +248°F
KUBV	Bellows, metal (cartridge), TC/carbon, FKM	+32°F to +194°F
KUHE	Bellows, metal (cartridge), TC/Carbon with embedded TC, EPDM	+32°F to +194°F
KUHV	Bellows, metal (cartridge), TC/Carbon with embedded TC, FKM	+32°F to +194°F
KUUE	Bellows, metal (cartridge), TC/TC, EPDM	-22°F to +194°F
KUUU	Bellows, metal (cartridge), TC/TC, FKM	-4°F to +194°F

★ TC= tungsten carbide

In case of extreme temperatures, i.e.

- low temperatures down to -40°F or
- high temperatures up to +356°F,

see "List of variants - on request" page 75.

Maximum inlet pressure

The following table shows the maximum permissible inlet pressure. However, the current inlet pressure + the pressure against a closed valve **must** always be lower than the maximum permissible operating pressure.

If the maximum permissible operating pressure is exceeded, the conical bearing in the motor may be damaged and the life of the shaft seal reduced.

CR, CRI, CRN 1s		
1s-2	→ 1s-27	145 [psi]
CR(E), CRI(E), CRN(E) 1		
1-2	→ 1-25	145 [psi]
1-27		218 [psi]
CR(E), CRI(E), CRN(E) 3		
3-2	→ 3-15	145 [psi]
3-17	→ 3-25	218 [psi]
CR(E), CRI(E), CRN(E) 5		
5-2	→ 5-9	145 [psi]
5-10	→ 5-24	218 [psi]
CR(E), CRI(E), CRN(E) 10		
10-1	→ 10-5	116 [psi]
10-6	→ 10-17	145 [psi]
CR(E), CRI(E), CRN(E) 15		
15-1	→ 15-2	116 [psi]
15-3	→ 15-12	145 [psi]
CR(E), CRI(E), CRN(E) 20		
20-1		116 [psi]
20-2	→ 20-10	145 [psi]
CR(E), CRN(E) 32		
32-1-1	→ 32-2	58 [psi]
32-3-2	→ 32-6	145 [psi]
32-7-2	→ 32-11-2	218 [psi]
CR(E), CRN(E) 45		
45-1-1	→ 45-1	58 [psi]
45-2-2	→ 45-3	145 [psi]
45-4-2	→ 45-8-1	218 [psi]
CR(E), CRN(E) 64		
64-1-1		58 [psi]
64-1	→ 64-2-1	145 [psi]
64-2	→ 64-5-2	218 [psi]
CR(E), CRN(E) 90		
90-1-1	→ 90-1	145 [psi]
90-2-1	→ 90-4-1	218 [psi]

Example of operating and inlet pressures

The values for operating and inlet pressures shown in the tables must not be considered individually but must always be compared, see the following examples:

Example 1:

The following pump type has been selected:
CR 3-10 A-A-A

Max. operating pressure: **232 psi**

Max. inlet pressure: **145 psi**

Discharge pressure against a closed valve: **139.2 psi**, see page 33.

This pump is **not** allowed to start at an inlet pressure of 145 psi, but at an inlet pressure of $232.0 - 139.2 = 92.8$ psi.

Example 2:

The following pump has been selected:
CR 10-2 A-GJ-A

Max. operating pressure: **232 psi**

Max. inlet pressure: **116 psi**

Discharge pressure against a closed valve:
42 psi (97 H[ft]), see page 41.

This pump is allowed to start at an inlet pressure of 116 psi, as the discharge pressure is only 42 psi, which results in an operating pressure of $116 + 42 = 158$ psi. On the contrary, the max. operating pressure of this pump is limited to 158 psi, as a higher operating pressure will require an inlet pressure of more than 116 psi.

In case the inlet or operating pressure exceeds the pressure permitted, see "Lists of variants - on request" page 75.

Selection of pumps

Selection of pumps should be based on

- The duty point of the pump (see section 1)
- Sizing data such as pressure loss as a result of height differences, friction loss in the pipework, pump efficiency etc. (see section 2)
- Pump materials (see section 3)
- Pump connections (see section 4)
- Shaft seal (see section 5).

1. Duty point of the pump

From a duty point it is possible to select a pump on the basis of the curve charts shown in the chapter of "Performance curves/Technical data" on pages 24-63.

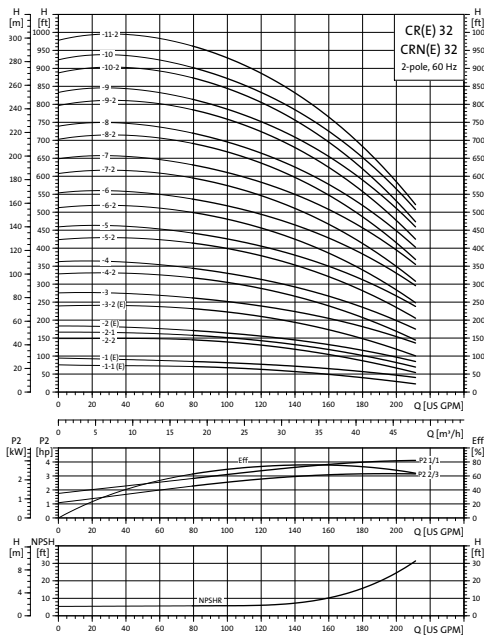

Fig. 16 Example of a curve chart

2. Sizing data

When sizing a pump the following must be taken into account.

- Required flow and pressure at the point of use.
- Pressure loss as a result of height differences (H_{geo}).
- Friction loss in the pipework (H_f). It may be necessary to account for pressure loss in connection with long pipes, bends or valves, etc.
- Best efficiency at the estimated duty point.
- NPSH value. For calculation of the NPSH value, see "Minimum inlet pressure - NPSH" page 22.

Efficiency

Before determining the point of best efficiency the operation pattern of the pump needs to be identified. Is the pump expected to operate at the same duty point, then select a CR pump which is operating at a duty point corresponding with the best efficiency of the pump.

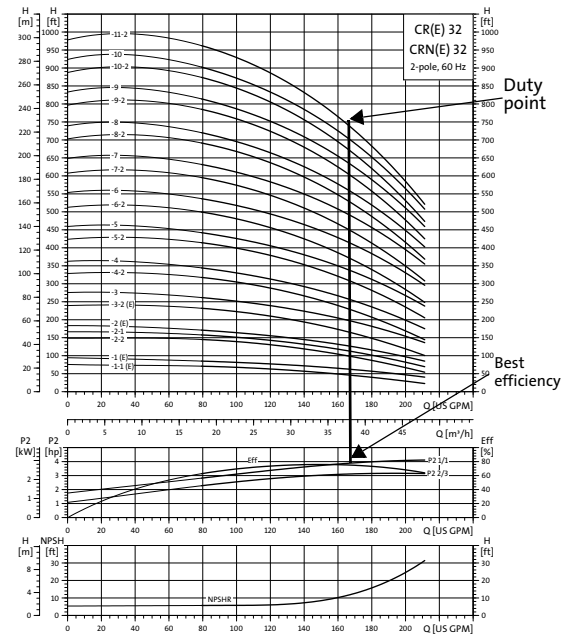

Fig. 17 Example of a CR pump's duty point

As the pump is sized on the basis of the highest possible flow, it is important to always have the duty point to the right of the optimum efficiency point (see fig. 18, range with check mark). This must be considered in order to keep efficiency high when the flow drops.

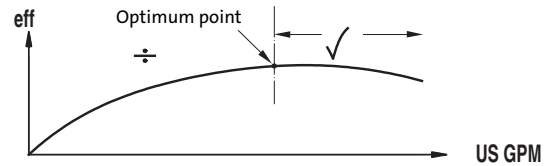

Fig. 18 Best efficiency

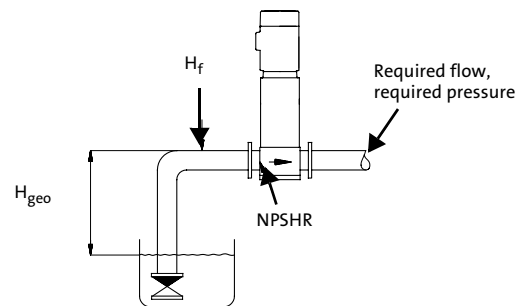

Fig. 19 Sizing data

Normally, E-pumps are used in applications characterized by a variable flow. Consequently, it is not possible to select a pump that is constantly operating at optimum efficiency.

In order to achieve optimum operating economy, the pump should be selected on the basis of the following criteria:

- The max. required duty point should be as close as possible to the QH curve of the pump.
- The required duty point should be positioned so that P_2 is close to the max. point of the 100% curve.

Between the min. and max. performance curve E-pumps have an infinite number of performance curves each representing a specific speed. Therefore it may not be possible to select a duty point close to the 100% curve.

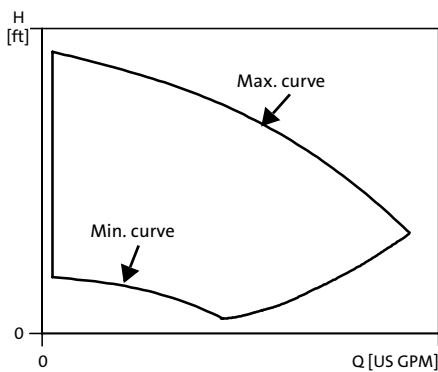

Fig. 20 Min. and max. performance curves

In situations where it is not possible to select a duty point close to the 100% curve the affinity equations to the right can be used. The head (H), the flow (Q) and the input power (P) are all the appropriate variables for the motor speed (n).

Note:

The approximated formulas apply on condition that the system characteristic remains unchanged for n_n and n_x and that it is based on the formula $H = k \times Q^2$, where k is a constant.

The power equation implies that the pump efficiency is unchanged at the two speeds. In practice this is **not** quite correct.

Finally, it is worth noting that the efficiencies of the frequency converter and the motor **must** be taken into account if a precise calculation of the power saving resulting from a reduction of the pump speed is wanted.

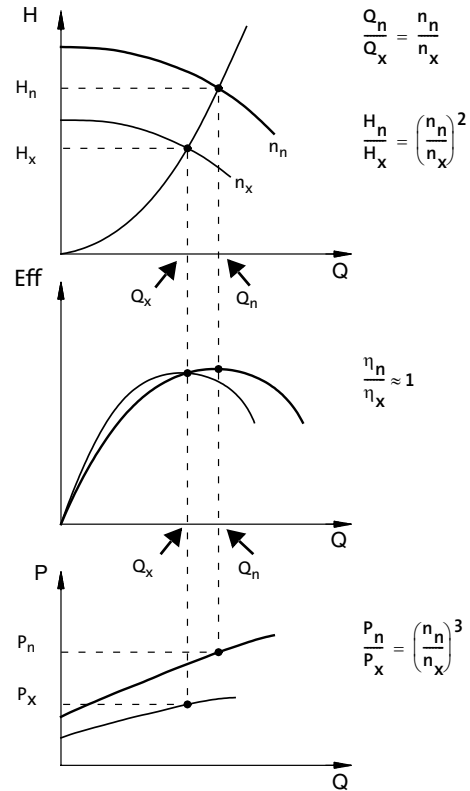

Fig. 21 Affinity equations

Legend

- H_n Rated head in feet
- H_x Current head in feet
- Q_n Rated flow in US GPM
- Q_x Current flow in US GPM
- n_n Rated motor speed in min^{-1} ($n_n = 3500 \text{ min}^{-1}$)
- n_x Current motor speed in min^{-1}
- η_n Rated efficiency in %
- η_x Current efficiency in %

WinCAPS® and WebCAPS®

WinCAPS and WebCAPS are both selection programs offered by Grundfos.

The two programs make it possible to calculate an E-pump's specific duty point and energy consumption.

By entering the sizing data of the pump, WinCAPS and WebCAPS can calculate the exact duty point and energy consumption. For further information see page 78 and page 79.

TM027572 4803

TM00 8720 3496

3. Material

The material variant (CR(E), CRI(E), CRN(E)) should be selected based on the liquid to be pumped. The product range covers three basic types.

- The CR(E), CRI(E) pump types are suitable for clean, non-aggressive liquids such as potable water, oils, etc.
- The CRN(E) pump type is suitable for industrial liquids and acids, see "List of pumped liquids" on page 66 or contact Grundfos.

For saline or chloride-containing liquids such as sea water, CRT(E) pumps of titanium are available.

4. Pump connection

Selection of pump connection depends on the rated pressure and pipework. To meet any requirement the CR(E), CRI(E) and CRN(E) pumps offer a wide range of flexible connections such as:

- Oval flange (NPT) - fig. 23
- ANSI flange - fig. 23
- PJE coupling - fig. 23
- Clamp coupling
- Union (NPT[M])
- Other connections on request.

5. Shaft seal

As standard, the CR(E) range is fitted with a Grundfos shaft seal (Cartridge type) suitable for the most common applications, see fig. 24.

The following three key parameters **must** be taken into account, when selecting the shaft seal:

- Type of pumped liquid
- liquid temperature and
- maximum pressure.

Grundfos offers a wide range of shaft seal variants to meet specific demands see "List of pumped liquids" on page 66.

Inlet pressure and operating pressure

The limit values stated on page 16 and page 18 must **not** be exceeded as regards ...

- maximum inlet pressure and
- maximum operating pressure.

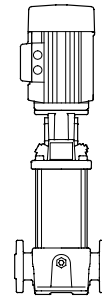

Fig. 22 CR pump

TM03 2155 3805

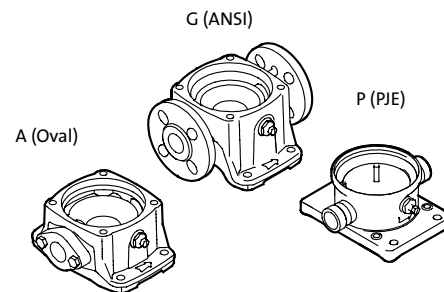

Fig. 23 Pump connections

TM02 1201 0601

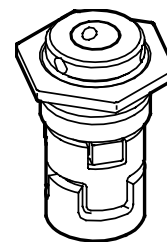

Fig. 24 Shaft seal (Cartridge type)

TM02 0538 4800

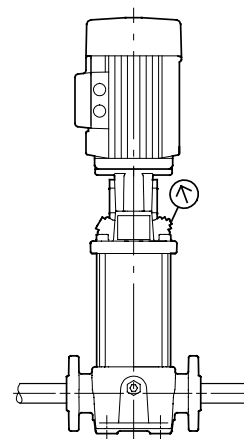

Fig. 25 Inlet and operating pressure

TM02 1204 0601

Minimum inlet pressure - NPSHR

Calculation of the inlet pressure "H" is recommended when

- the liquid temperature is high,
- the flow is significantly higher than the rated flow,
- water is drawn from depths,
- water is drawn through long pipes,
- inlet conditions are poor.

To avoid cavitation, make sure that there is a minimum pressure on the suction side of the pump. The maximum suction lift "H" in feet can be calculated as follows:

$$H = p_b - \text{NPSHR} - H_f - H_v - H_s$$

p_b = Barometric pressure in feet absolute.
(Barometric pressure can be set to 33.9 feet at sea level. In closed systems, p_b indicates system pressure in feet.)

NPSHR = Net Positive Suction Head Required in feet.
(To be read from the NPSHR curve at the highest flow the pump will be delivering.)

H_f = Friction loss in suction pipe in feet. (At the highest flow the pump will be delivering.)

H_v = Vapor pressure in feet.
(To be read from the vapor pressure scale. " H_v " depends on the liquid temperature " T_m ".)

H_s = Safety margin = minimum 2.0 feet.

If the "H" calculated is positive, the pump can operate at a suction lift of maximum "H" feet.

If the "H" calculated is negative, an inlet pressure of minimum "H" feet is required.

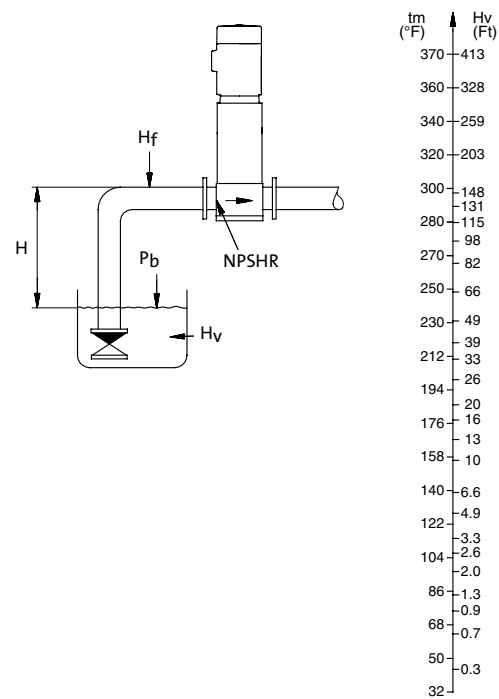

Fig. 26 Minimum inlet pressure - NPSHR

Note: In order to avoid cavitation **never**, select a pump whose duty point lies too far to the right on the NPSHR curve.

Always check the NPSHR value of the pump at the highest possible flow.

In case a lower NPSHR value is required, see "List of variants, on request" page 75.

TM02.7729.39.03

How to read the curve charts

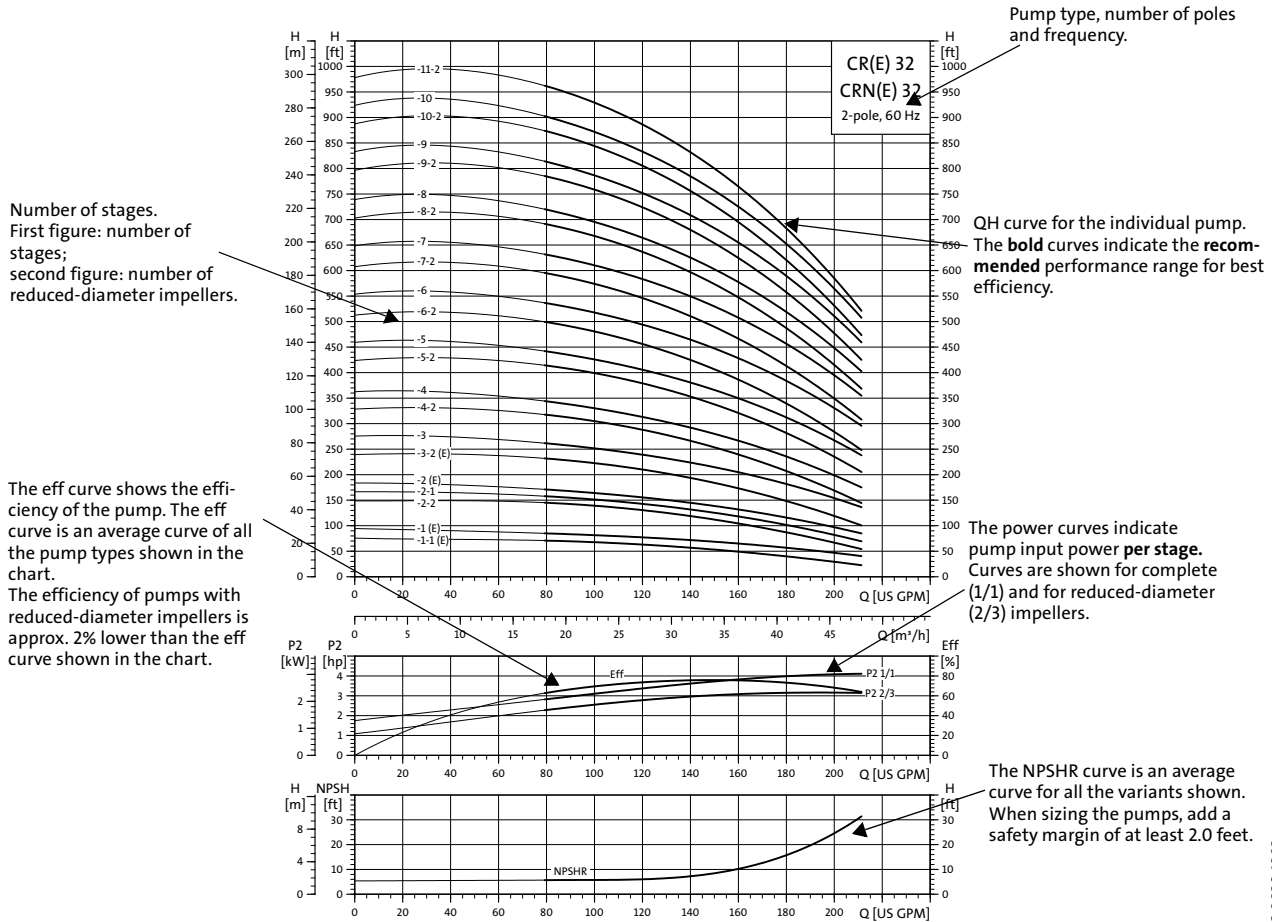

Fig. 27 How to read the curve charts

Guidelines to performance curves

The guidelines below apply to the curves shown on the following pages:

1. The motors used for the measurements are standard motors (ODP, TEFC or MLE).
2. Measurements have been made with airless water at a temperature of 68°F.
3. The curves apply to a kinematic viscosity of $\nu = 1 \text{ mm}^2/\text{s}$ (1 cSt).
4. Due to the risk of overheating, the pumps should not be used at a flow below the minimum flow rate.
5. The QH curves apply to actual speed with the motor types mentioned at 60 Hz.

The curve below shows the minimum flow rate as a percentage of the nominal flow rate in relation to the liquid temperature. The dotted line shows a CR pump fitted with an air-cooled top assembly.

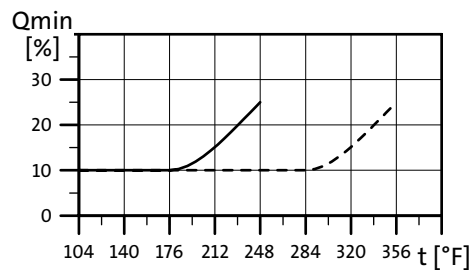

Fig. 28 Minimum flow rate

TM02 0039 1303

TM02 7538 3703

Performance curves

CR 1s, CRI 1s, CRN 1s

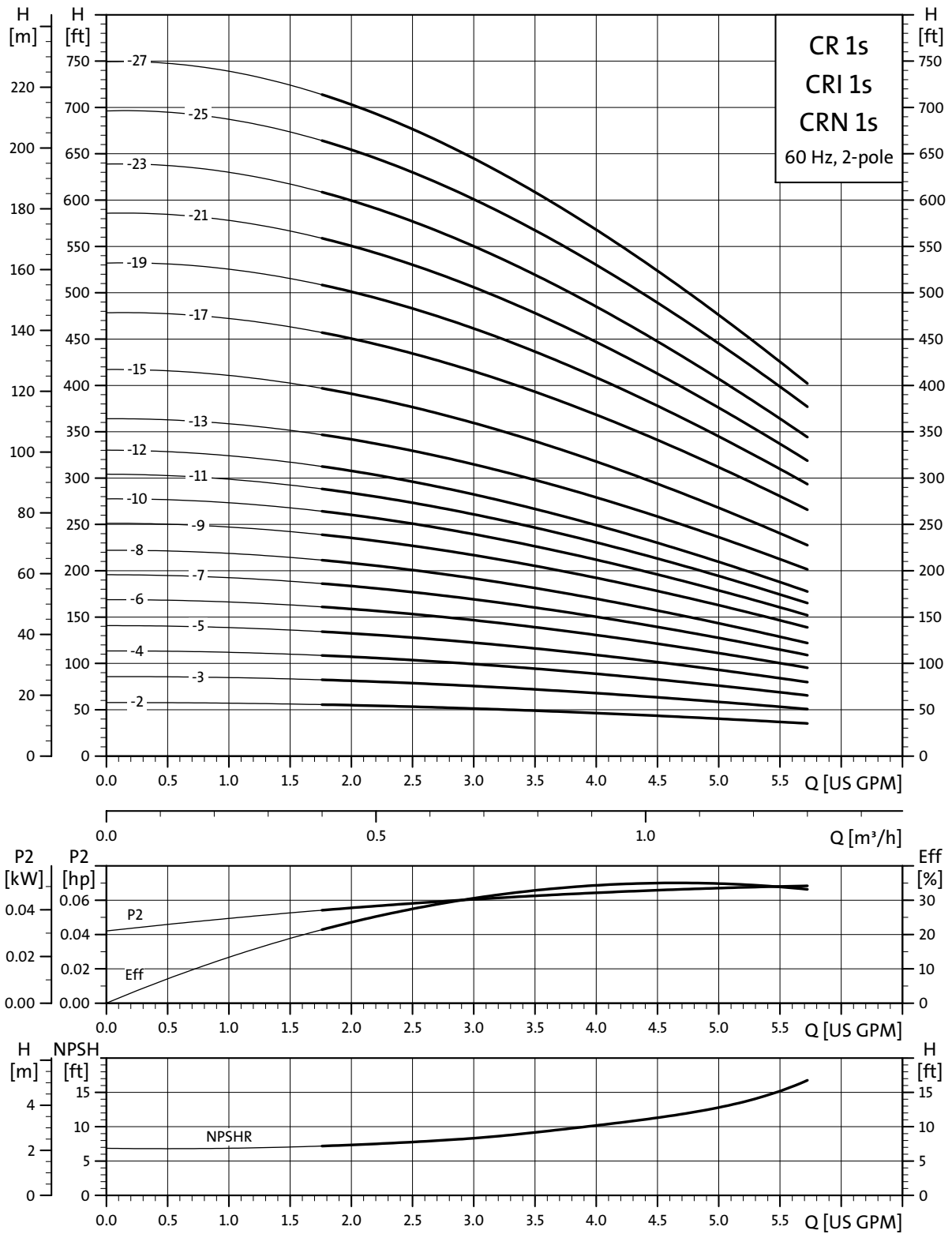

TM02.57411303

Dimensional sketches

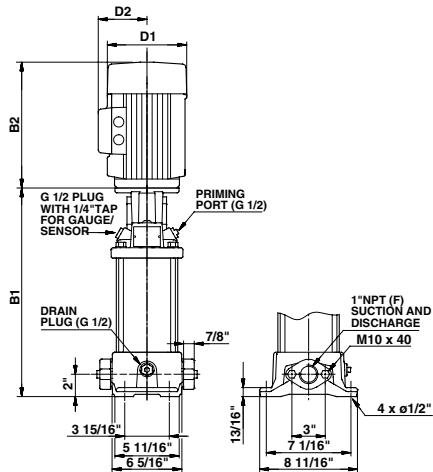

TM03 1450 2205

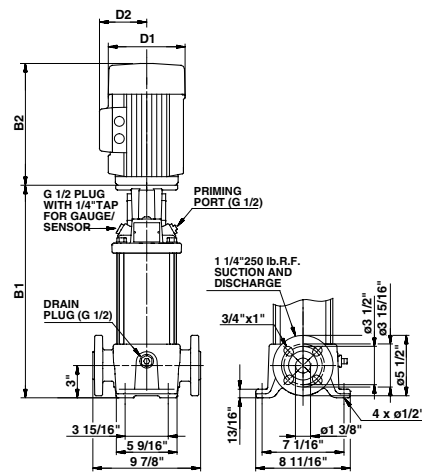

TM03 1451 2205

Dimensions and weights

Pump type	Hp	Ph	Voltage	NEMA Frame size	Oval B1	ANSI B1	TEFC				Oval Ship Wt. ¹ [lbs.]	ANSI Ship Wt. ¹ [lbs.]
							D1	D2	Oval B1+B2	ANSI B1+B2		
CR 1s-2	1/3	1	115/230	56C	11	12	6 1/4	5	20 3/8	21 3/8	53	62
		3	208-230/460	56C	11	12	5 5/8	4 5/8	18 5/8	19 5/8	53	62
CR 1s-3	1/3	1	115/230	56C	11	12	6 1/4	5	20 3/8	21 3/8	53	62
		3	208-230/460	56C	11	12	5 5/8	4 5/8	18 5/8	19 5/8	53	62
CR 1s-4	1/3	1	115/230	56C	11 3/4	12 3/4	6 1/4	5	21 1/8	22 1/8	54	63
		3	208-230/460	56C	11 3/4	12 3/4	5 5/8	4 5/8	19 3/8	20 3/8	53	62
CR 1s-5	1/3	1	115/230	56C	12 1/2	13 1/2	6 1/4	5	21 7/8	22 7/8	54	63
		3	208-230/460	56C	12 1/2	13 1/2	5 5/8	4 5/8	20 1/8	21 1/8	54	63
CR 1s-6	1/2	1	115/208-230	56C	13 1/8	14 1/8	6 1/4	5	22 1/2	23 1/2	54	63
		3	208-230/460	56C	13 1/8	14 1/8	5 5/8	4 5/8	20 3/4	21 3/4	54	63
CR 1s-7	1/2	1	115/208-230	56C	13 7/8	14 7/8	6 1/4	5	23 1/4	24 1/4	55	64
		3	208-230/460	56C	13 7/8	14 7/8	5 5/8	4 5/8	21 1/2	22 1/2	55	64
CR 1s-8	1/2	1	115/208-230	56C	14 5/8	15 5/8	6 1/4	5	24	25	57	66
		3	208-230/460	56C	14 5/8	15 5/8	5 5/8	4 5/8	22 1/4	23 1/4	57	66
CR 1s-9	3/4	1	115/208-230	56C	15 1/4	16 1/4	6 1/4	5	25 1/4	26 1/4	60	70
		3	208-230/460	56C	15 1/4	16 1/4	5 5/8	4 5/8	22 7/8	23 7/8	59	69
CR 1s-10	3/4	1	115/208-230	56C	16	17	6 1/4	5	26	27	61	71
		3	208-230/460	56C	16	17	5 5/8	4 5/8	23 5/8	24 5/8	60	70
CR 1s-11	3/4	1	115/208-230	56C	16 3/4	17 3/4	6 1/4	5	26 3/4	27 3/4	63	73
		3	208-230/460	56C	16 3/4	17 3/4	5 5/8	4 5/8	24 3/8	25 3/8	62	72
CR 1s-12	3/4	1	115/208-230	56C	17 3/8	18 3/8	6 1/4	5	27 3/8	28 3/8	65	74
		3	208-230/460	56C	17 3/8	18 3/8	5 5/8	4 5/8	25	26	64	73
CR 1s-13	1	1	115/230	56C	18 1/8	19 1/8	7 1/4	5 3/4	29 3/8	30 3/8	67	76
		3	208-230/460	56C	18 1/8	19 1/8	5 5/8	4 5/8	27	28	67	76
CR 1s-15	1	1	115/230	56C	19 1/2	20 1/2	7 1/4	5 3/4	30 3/4	31 3/4	69	78
		3	208-230/460	56C	19 1/2	20 1/2	5 5/8	4 5/8	28 3/8	29 3/8	68	78
CR 1s-17	1 1/2	1	115/208-230	56C	21	22	7 1/4	5 3/4	32 3/4	33 3/4	76	85
		3	208-230/460	56C	21	22	5 5/8	4 5/8	29 7/8	30 7/8	68	73
CR 1s-19	1 1/2	1	115/208-230	56C	-	23 3/8	7 1/4	5 3/4	-	35 1/8	-	86
		3	208-230/460	56C	-	23 3/8	5 5/8	4 5/8	-	32 1/4	-	75
CR 1s-21	1 1/2	1	115/208-230	56C	-	24 3/4	7 1/4	5 3/4	-	36 1/2	-	88
		3	208-230/460	56C	-	24 3/4	5 5/8	4 5/8	-	33 5/8	-	76
CR 1s-23	1 1/2	1	115/208-230	56C	-	26 1/4	7 1/4	5 3/4	-	38	-	90
		3	208-230/460	56C	-	26 1/4	5 5/8	4 5/8	-	35 1/8	-	78
CR 1s-25	2	1	115/230	56C	-	27 5/8	7 1/4	5 3/4	-	40 1/4	-	97
		3	208-230/460	56C	-	27 5/8	7 1/8	4 3/8	-	39 1/8	-	100
CR 1s-27	2	1	115/230	56C	-	29	7 1/4	5 3/4	-	41 5/8	-	100
		3	208-230/460	56C	-	29	7 1/8	4 3/8	-	40 1/2	-	102

Weights are based on pump with TEFC motor (see price list for individual weights)
All dimensions in inches unless otherwise noted.

Dimensional sketches

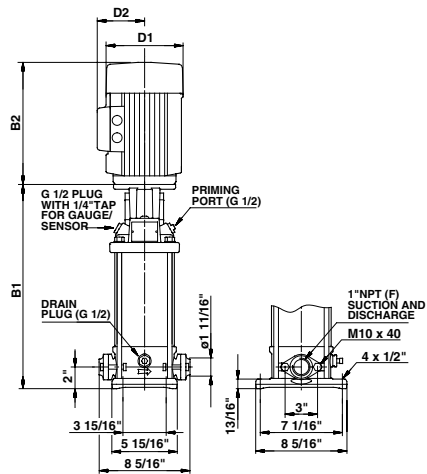

TM03 1452 2205

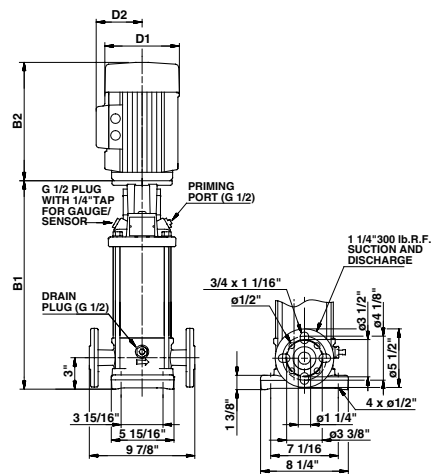

TM03 1453 2205

Dimensions and weights

Pump type	Hp	Ph	Voltage	NEMA Frame size	Oval B1	ANSI B1	TEFC				Oval Ship Wt. ¹ [lbs.]	ANSI Ship Wt. ¹ [lbs.]
							D1	D2	Oval B1+B2	ANSI B1+B2		
CRI 1s-2	1/3	1	115/230	56C	11 1/8	12 1/8	6 1/4	5	20 1/2	21 1/2	46	55
CRI 1s-2	1/3	3	208-230/460	56C	11 1/8	12 1/8	5 5/8	4 5/8	18 3/4	19 3/4	46	55
CRI 1s-3	1/3	1	115/230	56C	11 1/8	12 1/8	6 1/4	5	20 1/2	21 1/2	46	55
CRI 1s-3	1/3	3	208-230/460	56C	11 1/8	12 1/8	5 5/8	4 5/8	18 3/4	19 3/4	46	55
CRI 1s-4	1/3	1	115/230	56C	11 7/8	12 7/8	6 1/4	5	21 1/4	22 1/4	47	55
CRI 1s-4	1/3	3	208-230/460	56C	11 7/8	12 7/8	5 5/8	4 5/8	19 1/2	20 1/2	47	55
CRI 1s-5	1/3	1	115/230	56C	12 5/8	13 5/8	6 1/4	5	22	23	47	56
CRI 1s-5	1/3	3	208-230/460	56C	12 5/8	13 5/8	5 5/8	4 5/8	20 1/4	21 1/4	47	56
CRI 1s-6	1/2	1	115/208-230	56C	13 1/4	14 1/4	6 1/4	5	22 5/8	23 5/8	47	56
CRI 1s-6	1/2	3	208-230/460	56C	13 1/4	14 1/4	5 5/8	4 5/8	20 7/8	21 7/8	47	56
CRI 1s-7	1/2	1	115/208-230	56C	14	15	6 1/4	5	23 3/8	24 3/8	48	57
CRI 1s-7	1/2	3	208-230/460	56C	14	15	5 5/8	4 5/8	21 5/8	22 5/8	49	57
CRI 1s-8	1/2	1	115/208-230	56C	14 3/4	15 3/4	6 1/4	5	24 1/8	25 1/8	50	59
CRI 1s-8	1/2	3	208-230/460	56C	14 3/4	15 3/4	5 5/8	4 5/8	22 3/8	23 3/8	50	59
CRI 1s-9	3/4	1	115/208-230	56C	15 3/8	16 3/8	6 1/4	5	25 3/8	26 3/8	53	62
CRI 1s-9	3/4	3	208-230/460	56C	15 3/8	16 3/8	5 5/8	4 5/8	23	24	52	61
CRI 1s-10	3/4	1	115/208-230	56C	16 1/8	17 1/8	6 1/4	5	26 1/8	27 1/8	54	65
CRI 1s-10	3/4	3	208-230/460	56C	16 1/8	17 1/8	5 5/8	4 5/8	23 3/4	24 3/4	53	64
CRI 1s-11	3/4	1	115/208-230	56C	16 7/8	17 7/8	6 1/4	5	26 7/8	27 7/8	56	66
CRI 1s-11	3/4	3	208-230/460	56C	16 7/8	17 7/8	5 5/8	4 5/8	24 1/2	25 1/2	55	65
CRI 1s-12	3/4	1	115/208-230	56C	17 1/2	18 1/2	6 1/4	5	27 1/2	28 1/2	58	67
CRI 1s-12	3/4	3	208-230/460	56C	17 1/2	18 1/2	5 5/8	4 5/8	25 1/8	26 1/8	57	66
CRI 1s-13	1	1	115/230	56C	18 1/4	19 1/4	7 1/4	5 3/4	29 1/2	30 1/2	61	69
CRI 1s-13	1	3	208-230/460	56C	18 1/4	19 1/4	5 5/8	4 5/8	27 1/8	28 1/8	60	60
CRI 1s-15	1	1	115/230	56C	19 5/8	20 5/8	7 1/4	5 3/4	30 7/8	31 7/8	62	70
CRI 1s-15	1	3	208-230/460	56C	19 5/8	20 5/8	5 5/8	4 5/8	28 1/2	29 1/2	61	61
CRI 1s-17	1 1/2	1	115/208-230	56C	21 1/8	22 1/8	7 1/4	5 3/4	32 7/8	33 7/8	69	78
CRI 1s-17	1 1/2	3	208-230/460	56C	21 1/8	22 1/8	5 5/8	4 5/8	30	31	68	70
CRI 1s-19	1 1/2	1	115/208-230	56C	-	23 1/2	7 1/4	5 3/4	-	35 1/4	-	79
CRI 1s-19	1 1/2	3	208-230/460	56C	-	23 1/2	5 5/8	4 5/8	-	32 3/8	-	72
CRI 1s-21	1 1/2	1	115/208-230	56C	-	24 7/8	7 1/4	5 3/4	-	36 5/8	-	81
CRI 1s-21	1 1/2	3	208-230/460	56C	-	24 7/8	5 5/8	4 5/8	-	33 3/4	-	74
CRI 1s-23	1 1/2	1	115/208-230	56C	-	26 3/8	7 1/4	5 3/4	-	38 1/8	-	83
CRI 1s-23	1 1/2	3	208-230/460	56C	-	26 3/8	5 5/8	4 5/8	-	35 1/4	-	75
CRI 1s-25	2	1	115/230	56C	-	27 3/4	7 1/4	5 3/4	-	40 3/8	-	90
CRI 1s-25	2	3	208-230/460	56C	-	27 3/4	7 1/8	4 3/8	-	39 1/4	-	92
CRI 1s-27	2	1	115/230	56C	-	29 1/8	7 1/4	5 3/4	-	41 3/4	-	92
CRI 1s-27	2	3	208-230/460	56C	-	29 1/8	7 1/8	4 3/8	-	40 5/8	-	95

Weights are based on pump with TEFC motor (see price list for individual weights)
All dimensions in inches unless otherwise noted.

Dimensional sketches

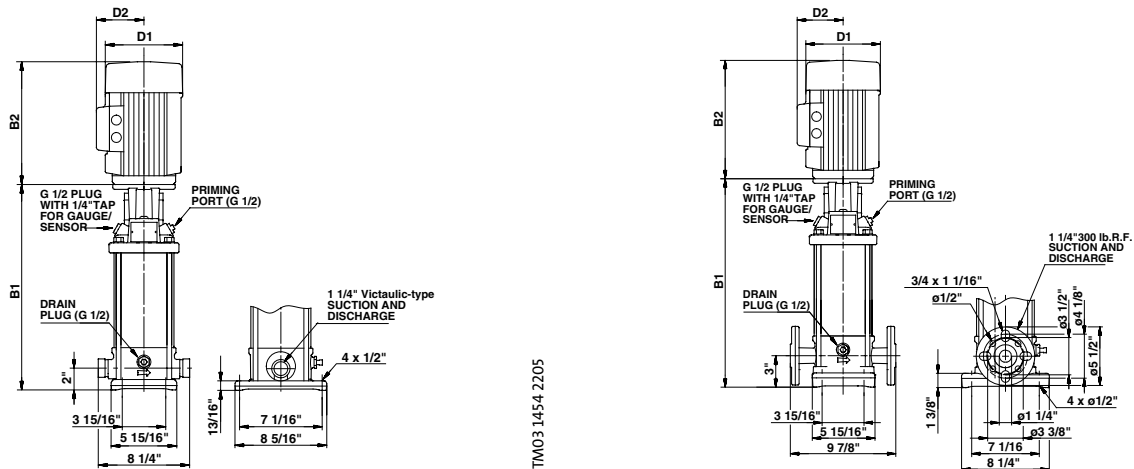

TM03 1454 2205

TM03 1453 2205

Dimensions and weights

Pump type	Hp	Ph	Voltage	NEMA Frame size	PJE B1	ANSI B1	TEFC				PJE Ship Wt. ¹ [lbs.]	ANSI Ship Wt. ¹ [lbs.]
							D1	D2	PJE B1+B2	ANSI B1+B2		
CRN 1s-2	1/3	1	115/230	56C	11 1/8	12 1/8	6 1/4	5	20 1/2	21 1/2	47	55
		3	208-230/460	56C	11 1/8	12 1/8	5 5/8	4 5/8	18 3/4	19 3/4	47	55
CRN 1s-3	1/3	1	115/230	56C	11 1/8	12 1/8	6 1/4	5	20 1/2	21 1/2	47	55
		3	208-230/460	56C	11 1/8	12 1/8	5 5/8	4 5/8	18 3/4	19 3/4	47	55
CRN 1s-4	1/3	1	115/230	56C	11 7/8	12 7/8	6 1/4	5	21 1/4	22 1/4	47	55
		3	208-230/460	56C	11 7/8	12 7/8	5 5/8	4 5/8	19 1/2	20 1/2	47	55
CRN 1s-5	1/3	1	115/230	56C	12 5/8	13 5/8	6 1/4	5	22	23	48	56
		3	208-230/460	56C	12 5/8	13 5/8	5 5/8	4 5/8	20 1/4	21 1/4	48	56
CRN 1s-6	1/2	1	115/208-230	56C	13 1/4	14 1/4	6 1/4	5	22 5/8	23 5/8	48	56
		3	208-230/460	56C	13 1/4	14 1/4	5 5/8	4 5/8	20 7/8	21 7/8	48	56
CRN 1s-7	1/2	1	115/208-230	56C	14	15	6 1/4	5	23 3/8	24 3/8	49	57
		3	208-230/460	56C	14	15	5 5/8	4 5/8	21 5/8	22 5/8	49	57
CRN 1s-8	1/2	1	115/208-230	56C	14 3/4	15 3/4	6 1/4	5	24 1/8	25 1/8	51	59
		3	208-230/460	56C	14 3/4	15 3/4	5 5/8	4 5/8	22 3/8	23 3/8	51	59
CRN 1s-9	3/4	1	115/208-230	56C	15 3/8	16 3/8	6 1/4	5	25 3/8	26 3/8	53	62
		3	208-230/460	56C	15 3/8	16 3/8	5 5/8	4 5/8	23	24	52	61
CRN 1s-10	3/4	1	115/208-230	56C	16 1/8	17 1/8	6 1/4	5	26 1/8	27 1/8	55	65
		3	208-230/460	56C	16 1/8	17 1/8	5 5/8	4 5/8	23 3/4	24 3/4	53	64
CRN 1s-11	3/4	1	115/208-230	56C	16 7/8	17 7/8	6 1/4	5	26 7/8	27 7/8	57	66
		3	208-230/460	56C	16 7/8	17 7/8	5 5/8	4 5/8	24 1/2	25 1/2	56	65
CRN 1s-12	3/4	1	115/208-230	56C	17 1/2	18 1/2	6 1/4	5	27 1/2	28 1/2	59	67
		3	208-230/460	56C	17 1/2	18 1/2	5 5/8	4 5/8	25 1/8	26 1/8	58	66
CRN 1s-13	1	1	115/230	56C	18 1/4	19 1/4	7 1/4	5 3/4	29 1/2	30 1/2	61	69
		3	208-230/460	56C	18 1/4	19 1/4	5 5/8	4 5/8	27 1/8	28 1/8	60	62
CRN 1s-15	1	1	115/230	56C	19 5/8	20 5/8	7 1/4	5 3/4	30 7/8	31 7/8	62	70
		3	208-230/460	56C	19 5/8	20 5/8	5 5/8	4 5/8	28 1/2	29 1/2	62	64
CRN 1s-17	1 1/2	1	115/208-230	56C	21 1/8	22 1/8	7 1/4	5 3/4	32 7/8	33 7/8	70	78
		3	208-230/460	56C	21 1/8	22 1/8	5 5/8	4 5/8	30	31	68	70
CRN 1s-19	1 1/2	1	115/208-230	56C	22 1/2	23 1/2	7 1/4	5 3/4	34 1/4	35 1/4	71	79
		3	208-230/460	56C	22 1/2	23 1/2	5 5/8	4 5/8	31 3/8	32 3/8	70	72
CRN 1s-21	1 1/2	1	115/208-230	56C	23 7/8	24 7/8	7 1/4	5 3/4	35 5/8	36 5/8	73	81
		3	208-230/460	56C	23 7/8	24 7/8	5 5/8	4 5/8	32 3/4	33 3/4	72	74
CRN 1s-23	1 1/2	1	115/208-230	56C	25 3/8	26 3/8	7 1/4	5 3/4	37 1/8	38 1/8	75	83
		3	208-230/460	56C	25 3/8	26 3/8	5 5/8	4 5/8	34 1/4	35 1/4	74	76
CRN 1s-25	2	1	115/230	56C	26 3/4	27 3/4	7 1/4	5 3/4	39 3/8	40 3/8	82	90
		3	208-230/460	56C	26 3/4	27 3/4	7 1/8	4 3/8	38 1/4	39 1/4	85	92
CRN 1s-27	2	1	115/230	56C	28 1/8	29 1/8	7 1/4	5 3/4	40 3/4	41 3/4	83	92
		3	208-230/460	56C	28 1/8	29 1/8	7 1/8	4 3/8	39 5/8	40 5/8	86	95

Weights are based on pump with TEFC motor (see price list for individual weights)
All dimensions in inches unless otherwise noted.

Performance curves

CR(E) 1, CRI(E) 1, CRN(E) 1

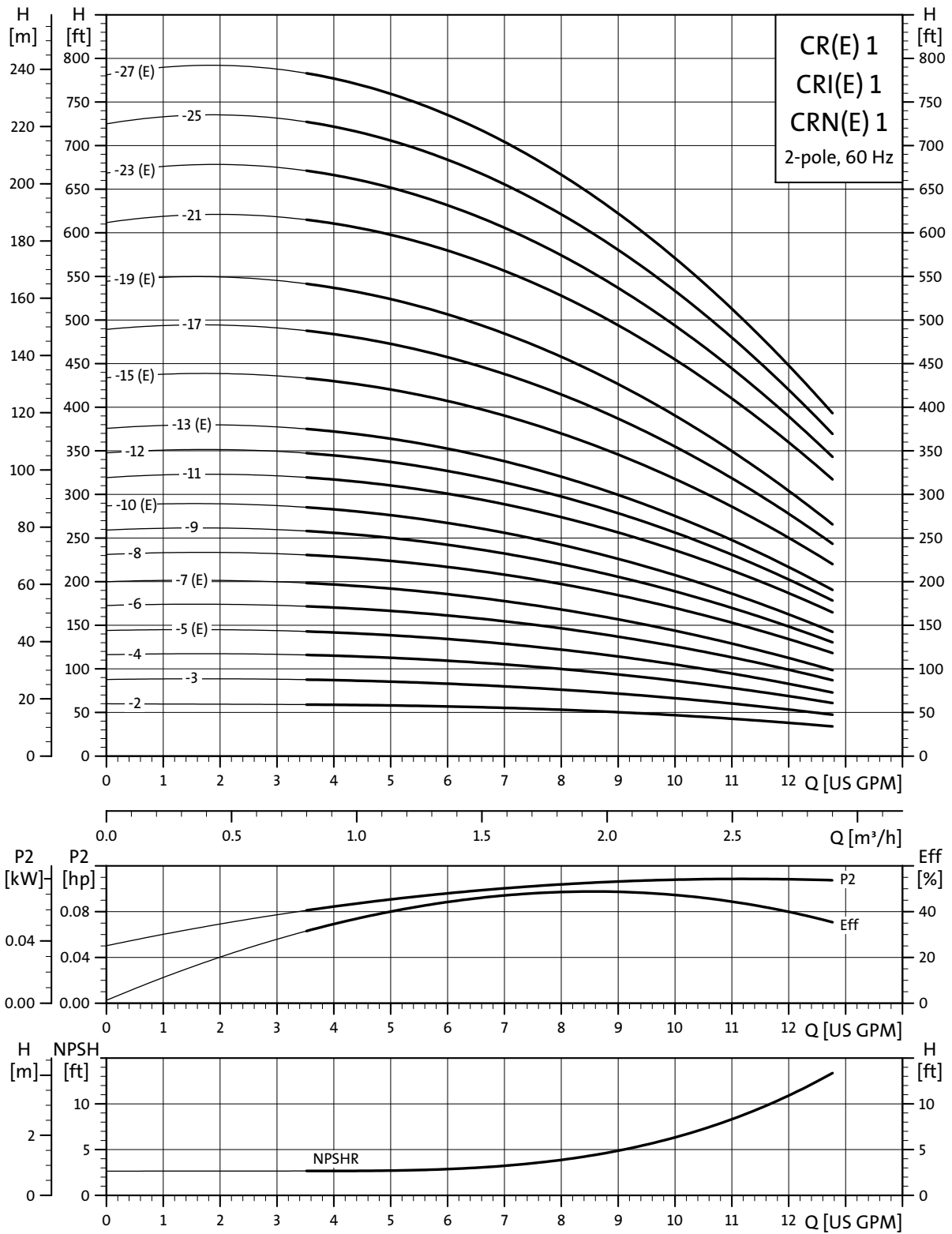

TM02 4083 1303

Dimensional sketches

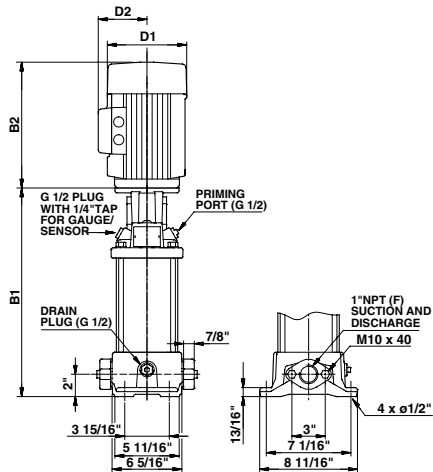

TM03 1450 2205

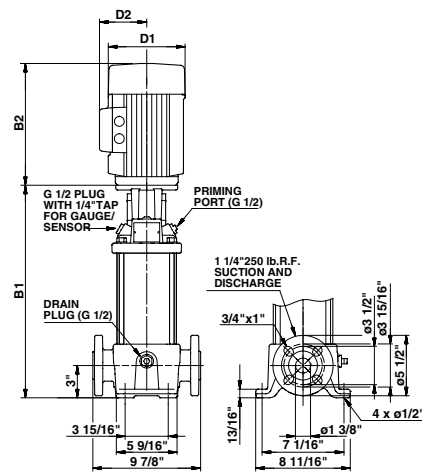

TM03 1451 2205

Dimensions and weights

Pump type	Hp	Ph	Voltage	NEMA Frame size	Oval B1	ANSI B1	TEFC				Oval Ship Wt. ¹ [lbs.]	ANSI Ship Wt. ¹ [lbs.]	MLE				Oval Ship Wt. ¹ [lbs.]	ANSI Ship Wt. ¹ [lbs.]
							D1	D2	Oval B1+B2	ANSI B1+B2			D1	D2	Oval B1+B2	ANSI B1+B2		
CR 1-2	1/3	1	115/230	56C	11	12	6 1/4	5	20 3/8	21 3/8	53	62	-	-	-	-	-	-
		3	208-230/460	56C	11	12	5 5/8	4 5/8	18 5/8	19 5/8	53	62	-	-	-	-	-	-
CR 1-3	1/3	1	115/230	56C	11	12	6 1/4	5	20 3/8	21 3/8	53	62	-	-	-	-	-	-
		3	208-230/460	56C	11	12	5 5/8	4 5/8	18 5/8	19 5/8	53	62	-	-	-	-	-	-
CR 1-4	1/2	1	115/208-230	56C	11 3/4	12 3/4	6 1/4	5	21 1/8	22 1/8	54	62	-	-	-	-	-	-
		3	208-230/460	56C	11 3/4	12 3/4	5 5/8	4 5/8	19 3/8	20 3/8	53	61	-	-	-	-	-	-
CR(E) 1-5	1/2	1	115/208-230	56C	12 1/2	13 1/2	6 1/4	5	21 7/8	22 7/8	54	62	5 1/2	5 1/2	20	21	55	64
		3	208-230/460	56C	12 1/2	13 1/2	5 5/8	4 5/8	20 1/8	21 1/8	53	61	-	-	-	-	-	-
CR 1-6	3/4	1	115/208-230	56C	13 1/8	14 1/8	6 1/4	5	23 1/8	24 1/8	56	65	-	-	-	-	-	-
		3	208-230/460	56C	13 1/8	14 1/8	5 5/8	4 5/8	20 3/4	21 3/4	55	64	-	-	-	-	-	-
CR(E) 1-7	3/4	1	115/208-230	56C	13 7/8	14 7/8	6 1/4	5	23 7/8	24 7/8	57	66	5 1/2	5 1/2	21 3/8	22 3/8	58	69
		3	208-230/460	56C	13 7/8	14 7/8	5 5/8	4 5/8	21 1/2	22 1/2	56	65	-	-	-	-	-	-
CR 1-8	1	1	115/230	56C	14 5/8	15 5/8	7 1/4	5 3/4	25 7/8	26 7/8	61	70	-	-	-	-	-	-
		3	208-230/460	56C	14 5/8	15 5/8	5 5/8	4 5/8	23 1/2	24 1/2	60	69	-	-	-	-	-	-
CR 1-9	1	1	115/230	56C	15 1/4	16 1/4	7 1/4	5 3/4	26 1/2	27 1/2	61	70	-	-	-	-	-	-
		3	208-230/460	56C	15 1/4	16 1/4	5 5/8	4 5/8	24 1/8	25 1/8	60	69	-	-	-	-	-	-
CR(E) 1-10	1	1	115/230	56C	16	17	7 1/4	5 3/4	27 1/4	28 1/4	62	71	5 1/2	5 1/2	27 1/8	26 1/8	67	76
		3	208-230/460	56C	16	17	5 5/8	4 5/8	24 7/8	25 7/8	61	70	7	6 5/8	27 1/2	28 1/2	78	88
CR 1-11	1 1/2	1	115/208-230	56C	16 3/4	17 3/4	7 1/4	5 3/4	28 1/2	29 1/2	72	81	-	-	-	-	-	-
		3	208-230/460	56C	16 3/4	17 3/4	5 5/8	4 5/8	25 5/8	26 5/8	64	75	-	-	-	-	-	-
CR 1-12	1 1/2	1	115/208-230	56C	17 3/8	18 3/8	7 1/4	5 3/4	29 1/8	30 1/8	73	82	-	-	-	-	-	-
		3	208-230/460	56C	17 3/8	18 3/8	5 5/8	4 5/8	26 1/4	27 1/4	65	76	-	-	-	-	-	-
CR(E) 1-13	1 1/2	1	115/208-230	56C	18 1/8	19 1/8	7 1/4	5 3/4	29 7/8	30 7/8	74	83	5 1/2	5 1/2	27 1/8	28 1/8	73	82
		3	208-230/460	56C	18 1/8	19 1/8	5 5/8	4 5/8	27	28	66	77	7	6 5/8	29 5/8	30 5/8	86	95
CR(E) 1-15	2	1	115/230	56C	19 1/2	20 1/2	7 1/4	5 3/4	32 1/8	33 1/8	79	88	-	-	-	-	-	-
		3	208-230/460	56C	19 1/2	20 1/2	7 1/8	4 3/8	31	32	82	91	7	6 5/8	30	31	100	109
CR 1-17	2	1	115/230	56C	21	22	7 1/4	5 3/4	33 5/8	34 5/8	81	90	-	-	-	-	-	-
		3	208-230/460	56C	21	22	7 1/8	4 3/8	32 1/2	33 1/2	83	92	-	-	-	-	-	-
CR(E) 1-19	2	1	115/230	56C	-	23 3/8	7 1/4	5 3/4	-	36	-	91	-	-	-	-	-	-
		3	208-230/460	56C	-	23 3/8	7 1/8	4 3/8	-	34 7/8	-	94	7	6 5/8	-	34 7/8	-	112
CR 1-21	3	1	115/208-230	182TC	-	25 7/8	8 5/8	6 7/8	-	40 3/8	-	109	-	-	-	-	-	-
		3	208-230/460	182TC	-	25 7/8	7 1/8	4 3/8	-	37 5/8	-	96	-	-	-	-	-	-
CR(E) 1-23	3	1	115/208-230	182TC	-	27 1/4	8 5/8	6 7/8	-	41 3/4	-	112	-	-	-	-	-	-
		3	208-230/460	182TC	-	27 1/4	7 1/8	4 3/8	-	39	-	99	7	6 5/8	-	40 5/8	-	127
CR 1-25	3	1	115/208-230	182TC	-	28 5/8	8 5/8	6 7/8	-	43 1/8	-	115	-	-	-	-	-	-
		3	208-230/460	182TC	-	28 5/8	7 1/8	4 3/8	-	40 3/8	-	102	-	-	-	-	-	-
CR(E) 1-27	3	1	115/208-230	182TC	-	30 1/8	8 5/8	6 7/8	-	44 5/8	-	116	-	-	-	-	-	-
		3	208-230/460	182TC	-	30 1/8	7 1/8	4 3/8	-	41 7/8	-	103	7	6 5/8	-	43 1/2	-	131

Weights are based on pump with TEFC motor (see price list for individual weights)
All dimensions in inches unless otherwise noted.

Dimensional sketches

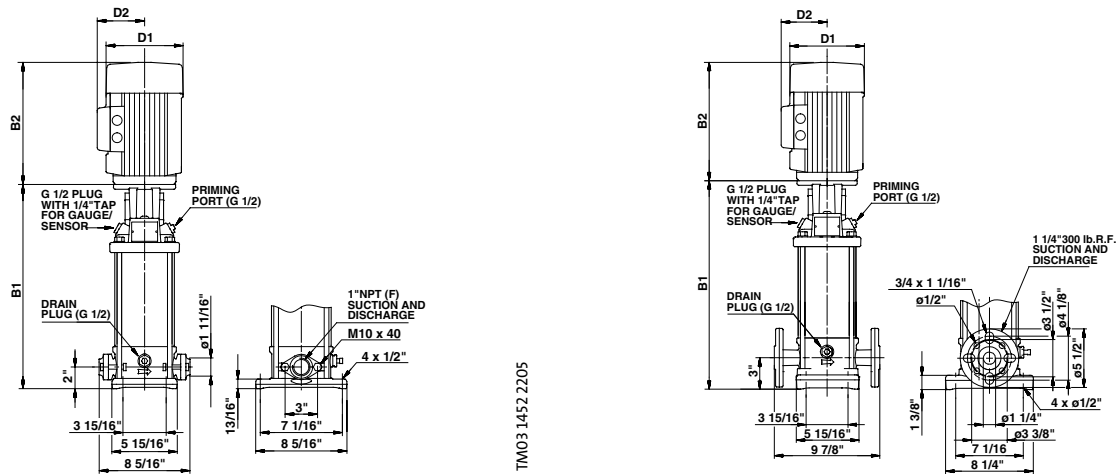

Dimensions and weights

Pump type	Hp	Ph	Voltage	NEMA Frame size	TEFC						Oval Ship Wt. ¹ [lbs.]	ANSI Ship Wt. ¹ [lbs.]	MLE				Oval Ship Wt. ¹ [lbs.]	ANSI Ship Wt. ¹ [lbs.]
					Oval B1	ANSI B1	D1	D2	Oval B1+B2	ANSI B1+B2			D1	D2	Oval B1+B2	ANSI B1+B2		
CRI 1-2	1/3	1	115/230	56C	11 1/8	12 1/8	6 1/4	5	20 1/2	21 1/2	46	55	-	-	-	-	-	-
		3	208-230/460	56C	11 1/8	12 1/8	5 5/8	4 5/8	18 3/4	19 3/4	46	55	-	-	-	-	-	-
CRI 1-3	1/3	1	115/230	56C	11 1/8	12 1/8	6 1/4	5	20 1/2	21 1/2	46	55	-	-	-	-	-	-
		3	208-230/460	56C	11 1/8	12 1/8	5 5/8	4 5/8	18 3/4	19 3/4	46	55	-	-	-	-	-	-
CRI 1-4	1/2	1	115/208-230	56C	11 7/8	12 7/8	6 1/4	5	21 1/4	22 1/4	47	56	-	-	-	-	-	-
		3	208-230/460	56C	11 7/8	12 7/8	5 5/8	4 5/8	19 1/2	20 1/2	46	55	-	-	-	-	-	-
CRI(E) 1-5	1/2	1	115/208-230	56C	12 5/8	13 5/8	6 1/4	5	22	23	48	56	5 1/2	5 1/2	20 1/8	21 1/8	48	57
		3	208-230/460	56C	12 5/8	13 5/8	5 5/8	4 5/8	20 1/4	21 1/4	47	55	-	-	-	-	-	-
CRI 1-6	3/4	1	115/208-230	56C	13 1/4	14 1/4	6 1/4	5	23 1/4	24 1/4	49	57	-	-	-	-	-	-
		3	208-230/460	56C	13 1/4	14 1/4	5 5/8	4 5/8	20 7/8	21 7/8	48	56	-	-	-	-	-	-
CRI(E) 1-7	3/4	1	115/208-230	56C	14	15	6 1/4	5	24	25	50	59	5 1/2	5 1/2	21 1/2	22 1/2	52	61
		3	208-230/460	56C	14	15	5 5/8	4 5/8	21 5/8	22 5/8	49	58	-	-	-	-	-	-
CRI 1-8	1	1	115-230	56C	14 3/4	15 3/4	7 1/4	5 3/4	26	27	54	63	-	-	-	-	-	-
		3	208-230/460	56C	14 3/4	15 3/4	5 5/8	4 5/8	23 5/8	24 5/8	52	60	-	-	-	-	-	-
CRI 1-9	1	1	115-230	56C	15 3/8	16 3/8	7 1/4	5 3/4	26 5/8	27 5/8	55	63	-	-	-	-	-	-
		3	208-230/460	56C	15 3/8	16 3/8	5 5/8	4 5/8	24 1/4	25 1/4	53	61	-	-	-	-	-	-
CRI(E) 1-10	1	1	115-230	56C	16 1/8	17 1/8	7 1/4	5 3/4	27 3/8	28 3/8	56	64	5 1/2	5 1/2	25 1/4	26 1/4	60	69
		3	208-230/460	56C	16 1/8	17 1/8	5 5/8	4 5/8	25	26	54	62	7	6 5/8	27 5/8	28 5/8	71	82
CRI 1-11	1 1/2	1	115/208-230	56C	16 7/8	17 7/8	7 1/4	5 3/4	28 5/8	29 5/8	65	74	-	-	-	-	-	-
		3	208-230/460	56C	16 7/8	17 7/8	5 5/8	4 5/8	25 3/4	26 3/4	63	72	-	-	-	-	-	-
CRI 1-12	1 1/2	1	115/208-230	56C	17 1/2	18 1/2	7 1/4	5 3/4	29 1/4	30 1/4	66	75	-	-	-	-	-	-
		3	208-230/460	56C	17 1/2	18 1/2	5 5/8	4 5/8	26 3/8	27 3/8	64	73	-	-	-	-	-	-
CRI(E) 1-13	1 1/2	1	115/208-230	56C	18 1/4	19 1/4	7 1/4	5 3/4	30	31	67	76	5 1/2	5 1/2	27 3/8	28 3/8	66	74
		3	208-230/460	56C	18 1/4	19 1/4	5 5/8	4 5/8	27 1/8	28 1/8	65	74	7	6 5/8	29 3/4	30 3/4	79	88
CRI(E) 1-15	2	1	115-230	56C	19 5/8	20 5/8	7 1/4	5 3/4	32 1/4	33 1/4	73	81	-	-	-	-	-	-
		3	208-230/460	56C	19 5/8	20 5/8	7 1/8	4 3/8	31 1/8	32 1/8	75	84	7	6 5/8	31 1/8	32 1/8	93	102
CRI 1-17	2	1	115-230	56C	21 1/8	22 1/8	7 1/4	5 3/4	33 3/4	34 3/4	74	82	-	-	-	-	-	-
		3	208-230/460	56C	21 1/8	22 1/8	7 1/8	4 3/8	32 5/8	33 5/8	76	85	-	-	-	-	-	-
CRI(E) 1-19	2	1	115-230	56C	-	23 1/2	7 1/4	5 3/4	-	36 1/8	-	84	-	-	-	-	-	-
		3	208-230/460	56C	-	23 1/2	7 1/8	4 3/8	-	35	-	86	7	6 5/8	-	35	-	104
CRI 1-21	3	1	115/208-230	182TC	-	26	8 5/8	6 7/8	-	40 1/2	-	102	-	-	-	-	-	-
		3	208-230/460	182TC	-	26	7 1/8	4 3/8	-	37 3/4	-	89	-	-	-	-	-	-
CRI(E) 1-23	3	1	115/208-230	182TC	-	27 3/8	8 5/8	6 7/8	-	41 7/8	-	105	-	-	-	-	-	-
		3	208-230/460	182TC	-	27 3/8	7 1/8	4 3/8	-	39 1/8	-	92	7	6 5/8	-	40 3/4	-	120
CRI 1-25	3	1	115/208-230	182TC	-	28 3/4	8 5/8	6 7/8	-	43 1/4	-	107	-	-	-	-	-	-
		3	208-230/460	182TC	-	28 3/4	7 1/8	4 3/8	-	40 1/2	-	94	-	-	-	-	-	-
CRI 1-27	3	1	115/208-230	182TC	-	30 1/4	8 5/8	6 7/8	-	44 3/4	-	109	-	-	-	-	-	-
		3	208-230/460	182TC	-	30 1/4	7 1/8	4 3/8	-	42	-	96	-	-	-	-	-	-

Weights are based on pump with TEFC motor (see price list for individual weights)

All dimensions in inches unless otherwise noted.

Dimensional sketches

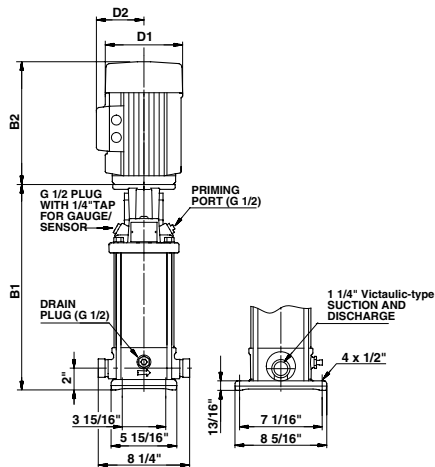

TM03 1454 2205

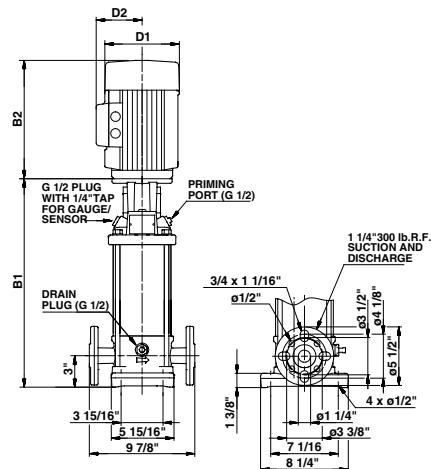

TM03 1454 2205

Dimensions and weights

Pump type	Hp	Ph	Voltage	NEMA Frame size	PJE B1	ANSI B1	TEFC				PJE Ship Wt. ¹ [lbs.]	ANSI Ship Wt. ¹ [lbs.]	MLE					
							D1	D2	PJE B1+B2	ANSI B1+B2			D1	D2	PJE B1+B2	ANSI B1+B2	PJE Ship Wt. ¹ [lbs.]	ANSI Ship Wt. ¹ [lbs.]
CRN 1-2	1/3	1	115/230	56C	11 1/8	12 1/8	6 1/4	5	20 1/2	21 1/2	47	55	-	-	-	-	-	-
		3	208-230/460	56C	11 1/8	12 1/8	5 5/8	4 5/8	18 3/4	19 3/4	47	55	-	-	-	-	-	-
CRN 1-3	1/3	1	115/230	56C	11 1/8	12 1/8	6 1/4	5	20 1/2	21 1/2	47	55	-	-	-	-	-	-
		3	208-230/460	56C	11 1/8	12 1/8	5 5/8	4 5/8	18 3/4	19 3/4	47	55	-	-	-	-	-	-
CRN 1-4	1/2	1	115/208-230	56C	11 7/8	12 7/8	6 1/4	5	21 1/4	22 1/4	48	54	-	-	-	-	-	-
		3	208-230/460	56C	11 7/8	12 7/8	5 5/8	4 5/8	19 1/2	20 1/2	47	54	-	-	-	-	-	-
CRN(E) 1-5	1/2	1	115/208-230	56C	12 5/8	13 5/8	6 1/4	5	22	23	49	55	5 1/2	5 1/2	20 1/8	21 1/8	48	57
		3	208-230/460	56C	12 5/8	13 5/8	5 5/8	4 5/8	20 1/4	21 1/4	48	55	-	-	-	-	-	-
CRN 1-6	3/4	1	115/208-230	56C	13 1/4	14 1/4	6 1/4	5	23 1/4	24 1/4	52	57	-	-	-	-	-	-
		3	208-230/460	56C	13 1/4	14 1/4	5 5/8	4 5/8	20 7/8	21 7/8	50	56	-	-	-	-	-	-
CRN(E) 1-7	3/4	1	115/208-230	56C	14	15	6 1/4	5	24	25	52	59	5 1/2	5 1/2	23 1/2	24 1/2	52	61
		3	208-230/460	56C	14	15	5 5/8	4 5/8	21 5/8	22 5/8	50	58	-	-	-	-	-	-
CRN 1-8	1	1	115-230	56C	14 3/4	15 3/4	7 1/4	5 3/4	26	27	55	62	-	-	-	-	-	-
		3	208-230/460	56C	14 3/4	15 3/4	5 5/8	4 5/8	23 5/8	24 5/8	51	58	-	-	-	-	-	-
CRN 1-9	1	1	115-230	56C	15 3/8	16 3/8	7 1/4	5 3/4	26 5/8	27 5/8	56	63	-	-	-	-	-	-
		3	208-230/460	56C	15 3/8	16 3/8	5 5/8	4 5/8	24 1/4	25 1/4	52	59	-	-	-	-	-	-
CRN(E) 1-10	1	1	115-230	56C	16 1/8	17 1/8	7 1/4	5 3/4	27 3/8	28 3/8	57	64	5 1/2	5 1/2	25 1/4	26 1/4	60	69
		3	208-230/460	56C	16 1/8	17 1/8	5 5/8	4 5/8	25	26	53	60	7	6 5/8	27 5/8	28 5/8	71	82
CRN 1-11	1 1/2	1	115/208-230	56C	16 7/8	17 7/8	7 1/4	5 3/4	28 5/8	29 5/8	66	74	-	-	-	-	-	-
		3	208-230/460	56C	16 7/8	17 7/8	5 5/8	4 5/8	25 3/4	26 3/4	60	68	-	-	-	-	-	-
CRN 1-12	1 1/2	1	115/208-230	56C	17 1/2	18 1/2	7 1/4	5 3/4	29 1/4	30 1/4	67	75	-	-	-	-	-	-
		3	208-230/460	56C	17 1/2	18 1/2	5 5/8	4 5/8	26 3/8	27 3/8	61	69	-	-	-	-	-	-
CRN(E) 1-13	1 1/2	1	115/208-230	56C	18 1/4	19 1/4	7 1/4	5 3/4	30	31	67	75	5 1/2	5 1/2	27 3/8	28 3/8	66	74
		3	208-230/460	56C	18 1/4	19 1/4	5 5/8	4 5/8	27 1/8	28 1/8	61	69	7	6 5/8	29 3/4	30 3/4	79	88
CRN(E) 1-15	2	1	115-230	56C	19 5/8	20 5/8	7 1/4	5 3/4	32 1/4	33 1/4	73	81	-	-	-	-	-	-
		3	208-230/460	56C	19 5/8	20 5/8	7 1/8	4 3/8	31 1/8	32 1/8	76	84	7	6 5/8	31 1/8	32 1/8	93	102
CRN 1-17	2	1	115-230	56C	21 1/8	22 1/8	7 1/4	5 3/4	33 3/4	34 3/4	74	82	-	-	-	-	-	-
		3	208-230/460	56C	21 1/8	22 1/8	7 1/8	4 3/8	32 5/8	33 5/8	77	85	-	-	-	-	-	-
CRN(E) 1-19	2	1	115-230	56C	22 1/2	23 1/2	7 1/4	5 3/4	35 1/8	36 1/8	76	84	-	-	-	-	-	-
		3	208-230/460	56C	22 1/2	23 1/2	7 1/8	4 3/8	34	35	78	86	7	6 5/8	34	35	-	104
CRN 1-21	3	1	115/208-230	182TC	25	26	8 5/8	6 7/8	39 1/2	40 1/2	94	102	-	-	-	-	-	-
		3	208-230/460	182TC	25	26	7 1/8	4 3/8	36 3/4	37 3/4	81	89	-	-	-	-	-	-
CRN(E) 1-23	3	1	115/208-230	182TC	26 3/8	27 3/8	8 5/8	6 7/8	40 7/8	41 7/8	96	105	-	-	-	-	-	-
		3	208-230/460	182TC	26 3/8	27 3/8	7 1/8	4 3/8	38 1/8	39 1/8	83	92	7	6 5/8	39 3/4	40 3/4	-	120
CRN 1-25	3	1	115/208-230	182TC	27 7/8	28 3/4	8 5/8	6 7/8	42 3/8	43 1/4	99	107	-	-	-	-	-	-
		3	208-230/460	182TC	27 7/8	28 3/4	7 1/8	4 3/8	39 5/8	40 1/2	86	94	-	-	-	-	-	-
CRN(E) 1-27	3	1	115/208-230	182TC	29 1/4	30 1/4	8 5/8	6 7/8	43 3/4	44 3/4	101	109	-	-	-	-	-	-
		3	208-230/460	182TC	29 1/4	30 1/4	7 1/8	4 3/8	41	42	88	96	7	6 5/8	42 5/8	43 5/8	-	124

Weights are based on pump with TEFC motor (see price list for individual weights)

All dimensions in inches unless otherwise noted.

Performance curves

CR(E) 3, CRI(E) 3, CRN(E) 3

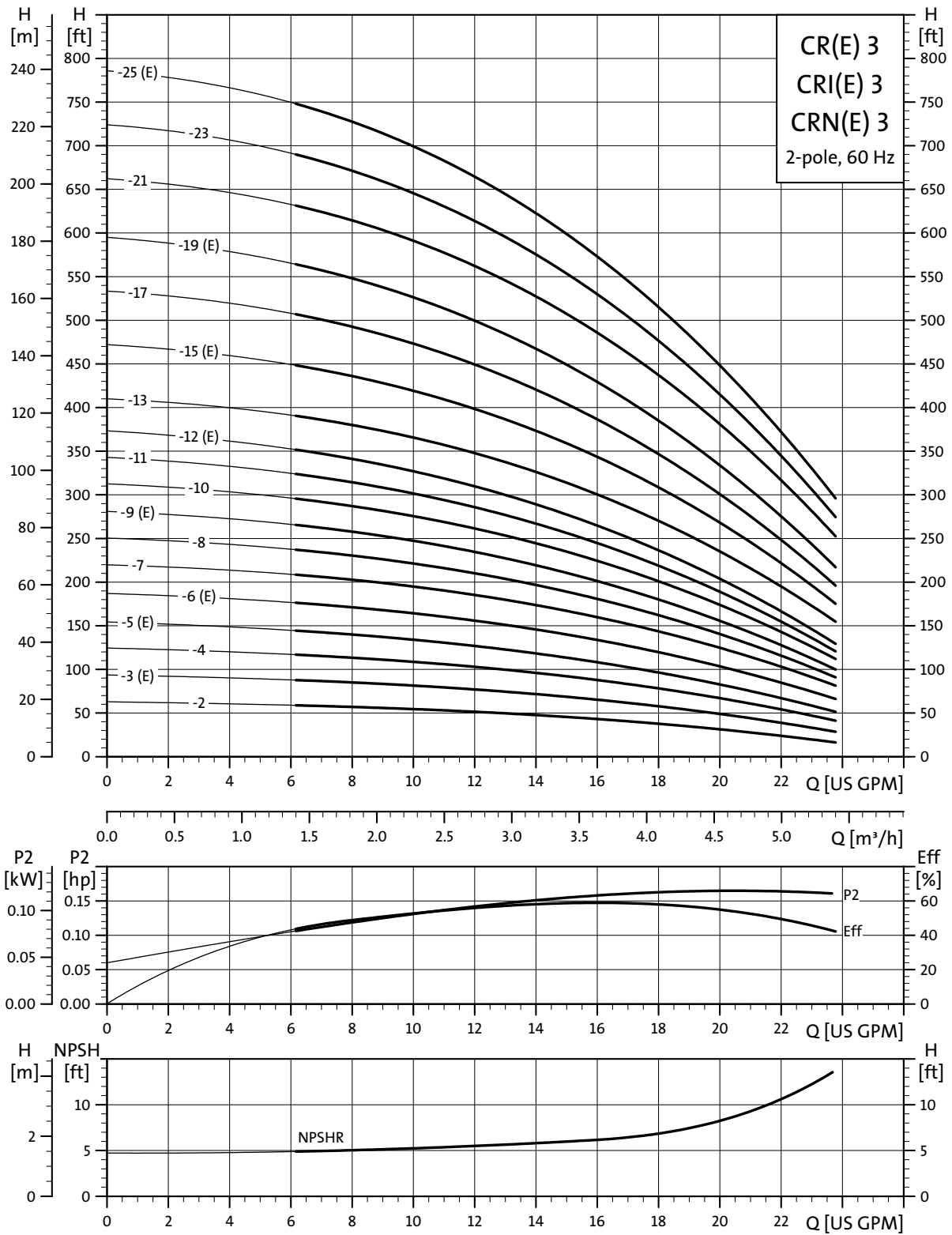

TM02 4084 1303

Dimensional sketches

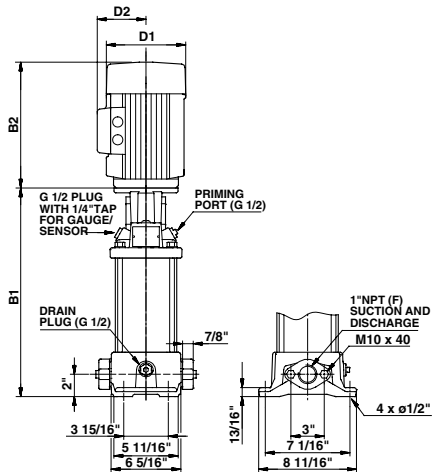

TM03 1450 2205

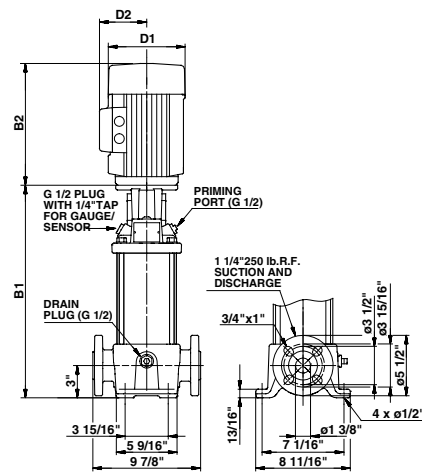

TM03 1451 2205

Dimensions and weights

Pump type	Hp	Ph	Voltage	NEMA Frame size	TEFC								MLE					
					Oval B1	ANSI B1	D1	D2	Oval B1+B2	ANSI B1+B2	Oval Ship Wt. ¹ [lbs.]	ANSI Ship Wt. ¹ [lbs.]	D1	D2	Oval B1+B2	ANSI B1+B2	Oval Ship Wt. ¹ [lbs.]	ANSI Ship Wt. ¹ [lbs.]
CR 3-2	1/3	1	115/230	56C	11	12	6 1/4	5	20 3/8	21 3/8	53	62	-	-	-	-	-	-
		3	208-230/460	56C	11	12	5 5/8	4 5/8	18 5/8	19 5/8	53	62	-	-	-	-	-	-
CR(E) 3-3	1/2	1	115/230	56C	11	12	6 1/4	5	20 3/8	21 3/8	52	61	5 1/2	5 1/2	18 1/2	19 1/2	54	63
		3	208-230/460	56C	11	12	5 5/8	4 5/8	18 5/8	19 5/8	53	62	-	-	-	-	-	-
CR 3-4	3/4	1	115/208-230	56C	11 3/4	12 3/4	6 1/4	5	21 3/4	22 3/4	54	64	-	-	-	-	-	-
		3	208-230/460	56C	11 3/4	12 3/4	5 5/8	4 5/8	19 3/8	20 3/8	53	62	-	-	-	-	-	-
CR(E) 3-5	3/4	1	115/208-230	56C	12 1/2	13 1/2	6 1/4	5	22 1/2	23 1/2	55	64	5 1/2	5 1/2	20	21	57	66
		3	208-230/460	56C	12 1/2	13 1/2	5 5/8	4 5/8	20 1/8	21 1/8	54	63	-	-	-	-	-	-
CR(E) 3-6	1	1	115-230	56C	13 1/8	14 1/8	7 1/4	5 3/4	24 3/8	25 3/8	57	66	5 1/2	5 1/2	22 1/4	23 1/4	60	69
		3	208-230/460	56C	13 1/8	14 1/8	5 5/8	4 5/8	22	23	54	64	7	6 5/8	24 5/8	25 5/8	73	82
CR 3-7	1 1/2	1	115/208-230	56C	13 7/8	14 7/8	7 1/4	5 3/4	25 5/8	26 5/8	65	75	-	-	-	-	-	-
		3	208-230/460	56C	13 7/8	14 7/8	5 5/8	4 5/8	22 3/4	23 3/4	54	64	-	-	-	-	-	-
CR 3-8	1 1/2	1	115/208-230	56C	14 5/8	15 5/8	7 1/4	5 3/4	26 3/8	27 3/8	67	77	-	-	-	-	-	-
		3	208-230/460	56C	14 5/8	15 5/8	5 5/8	4 5/8	23 1/2	24 1/2	55	65	-	-	-	-	-	-
CR(E) 3-9	1 1/2	1	115/208-230	56C	15 1/4	16 1/4	7 1/4	5 3/4	27	28	69	79	5 1/2	5 1/2	24 3/8	25 3/8	69	78
		3	208-230/460	56C	15 1/4	16 1/4	5 5/8	4 5/8	24 1/8	25 1/8	57	67	7	6 5/8	26 3/4	27 3/4	81	91
CR 3-10	2	1	115-230	56C	16	17	7 1/4	5 3/4	28 5/8	29 5/8	74	84	-	-	-	-	-	-
		3	208-230/460	56C	16	17	7 1/8	4 3/8	27 1/2	28 1/2	77	87	-	-	-	-	-	-
CR 3-11	2	1	115-230	56C	16 3/4	17 3/4	7 1/4	5 3/4	29 3/8	30 3/8	77	86	-	-	-	-	-	-
		3	208-230/460	56C	16 3/4	17 3/4	7 1/8	4 3/8	28 1/4	29 1/4	79	88	-	-	-	-	-	-
CR(E) 3-12	2	1	115-230	56C	17 3/8	18 3/8	7 1/4	5 3/4	30	31	78	87	-	-	-	-	-	-
		3	208-230/460	56C	17 3/8	18 3/8	7 1/8	4 3/8	28 7/8	29 7/8	80	89	7	6 5/8	28 7/8	29 7/8	98	107
CR 3-13	3	1	115/208-230	182TC	19 1/4	20 1/8	8 5/8	6 7/8	33 3/4	34 5/8	95	104	-	-	-	-	-	-
		3	208-230/460	182TC	19 1/4	20 1/8	7 1/8	4 3/8	31	31 7/8	82	91	-	-	-	-	-	-
CR(E) 3-15	3	1	115/208-230	182TC	20 5/8	21 5/8	8 5/8	6 7/8	35 1/8	36 1/8	96	105	-	-	-	-	-	-
		3	208-230/460	182TC	20 5/8	21 5/8	7 1/8	4 3/8	32 3/8	33 3/8	83	92	7	6 5/8	34	35	111	120
CR 3-17	3	1	115/208-230	182TC	22	23	8 5/8	6 7/8	36 1/2	37 1/2	97	106	-	-	-	-	-	-
		3	208-230/460	182TC	22	23	7 1/8	4 3/8	33 3/4	34 3/4	84	93	-	-	-	-	-	-
CR(E) 3-19	3	1	115/208-230	182TC	-	24 3/8	8 5/8	6 7/8	-	38 7/8	-	107	-	-	-	-	-	-
		3	208-230/460	182TC	-	24 3/8	7 1/8	4 3/8	-	36 1/8	-	94	7	6 5/8	-	37 3/4	-	123
CR 3-21	5	1	208-230	182TC	-	25 7/8	10 5/8	7 1/2	-	41 1/4	-	116	-	-	-	-	-	-
		3	208-230/460	182TC	-	25 7/8	7 1/8	4 3/8	-	39 1/8	-	95	-	-	-	-	-	-
CR 3-23	5	1	208-230	182TC	-	27 1/4	10 5/8	7 1/2	-	42 5/8	-	118	-	-	-	-	-	-
		3	208-230/460	182TC	-	27 1/4	7 1/8	4 3/8	-	40 1/2	-	97	-	-	-	-	-	-
CR(E) 3-25	5	1	208-230	182TC	-	28 5/8	10 5/8	7 1/2	-	44	-	121	-	-	-	-	-	-
		3	208-230/460	182TC	-	28 5/8	7 1/8	4 3/8	-	41 7/8	-	99	8 3/4	7 1/2	-	44 1/8	-	162

Weights are based on pump with TEFC motor (see price list for individual weights)
All dimensions in inches unless otherwise noted.

Dimensional sketches

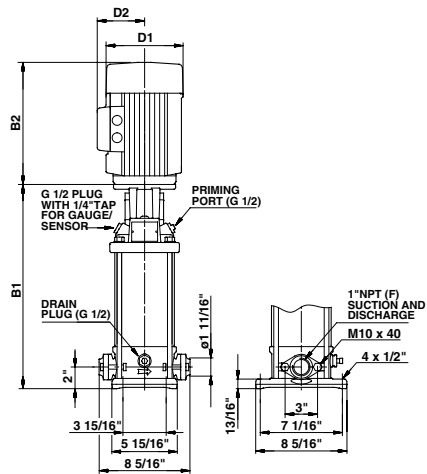

TM03 1452 2205

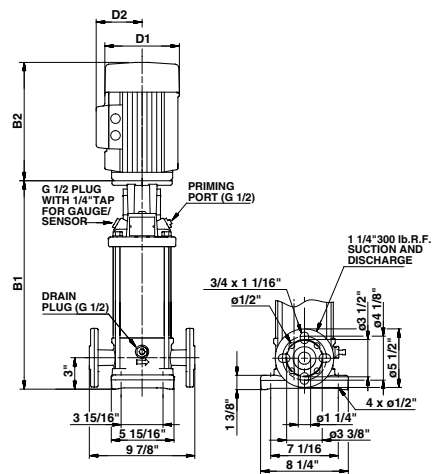

TM03 1453 2205

Dimensions and weights

Pump type	Hp	Ph	Voltage	NEMA Frame size	Oval B1	ANSI B1	TEFC				Oval Ship Wt. ¹ [lbs.]	ANSI Ship Wt. ¹ [lbs.]	MLE				Oval Ship Wt. ¹ [lbs.]	ANSI Ship Wt. ¹ [lbs.]
							D1	D2	Oval B1+B2	ANSI B1+B2			D1	D2	Oval B1+B2	ANSI B1+B2		
CRI 3-2	1/3	1	115/230	56C	11 1/8	12 1/8	6 1/4	5	20 1/2	21 1/2	46	55	-	-	-	-	-	-
		3	208-230/460	56C	11 1/8	12 1/8	5 5/8	4 5/8	18 3/4	19 3/4	46	55	-	-	-	-	-	-
CRI(E) 3-3	1/2	1	115/230	56C	11 1/8	12 1/8	6 1/4	5	20 1/2	21 1/2	45	54	5 1/2	5 1/2	18 5/8	19 5/8	47	56
		3	208-230/460	56C	11 1/8	12 1/8	5 5/8	4 5/8	18 3/4	19 3/4	46	55	-	-	-	-	-	-
CRI 3-4	3/4	1	115/208-230	56C	11 7/8	12 7/8	6 1/4	5	21 7/8	22 7/8	48	56	-	-	-	-	-	-
		3	208-230/460	56C	11 7/8	12 7/8	5 5/8	4 5/8	19 1/2	20 1/2	47	55	-	-	-	-	-	-
CRI(E) 3-5	3/4	1	115/208-230	56C	12 5/8	13 5/8	6 1/4	5	22 5/8	23 5/8	48	57	5 1/2	5 1/2	20 1/8	21 1/8	50	58
		3	208-230/460	56C	12 5/8	13 5/8	5 5/8	4 5/8	20 1/4	21 1/4	47	56	-	-	-	-	-	-
CRI(E) 3-6	1	1	115-230	56C	13 1/4	14 1/4	7 1/4	5 3/4	24 1/2	25 1/2	51	59	5 1/2	5 1/2	22 3/8	23 3/8	53	63
		3	208-230/460	56C	13 1/4	14 1/4	5 5/8	4 5/8	22 1/8	23 1/8	47	56	7	6 5/8	24 3/4	25 3/4	66	75
CRI 3-7	1 1/2	1	115/208-230	56C	14	15	7 1/4	5 3/4	25 3/4	26 3/4	58	68	-	-	-	-	-	-
		3	208-230/460	56C	14	15	5 5/8	4 5/8	22 7/8	23 7/8	48	57	-	-	-	-	-	-
CRI 3-8	1 1/2	1	115/208-230	56C	14 3/4	15 3/4	7 1/4	5 3/4	26 1/2	27 1/2	60	71	-	-	-	-	-	-
		3	208-230/460	56C	14 3/4	15 3/4	5 5/8	4 5/8	23 5/8	24 5/8	49	59	-	-	-	-	-	-
CRI(E) 3-9	1 1/2	1	115/208-230	56C	15 3/8	16 3/8	7 1/4	5 3/4	27 1/8	28 1/8	62	72	5 1/2	5 1/2	24 1/2	25 1/2	62	71
		3	208-230/460	56C	15 3/8	16 3/8	5 5/8	4 5/8	24 1/4	25 1/4	50	60	7	6 5/8	26 7/8	27 7/8	74	84
CRI 3-10	2	1	115-230	56C	16 1/8	17 1/8	7 1/4	5 3/4	28 3/4	29 3/4	69	77	-	-	-	-	-	-
		3	208-230/460	56C	16 1/8	17 1/8	7 1/8	4 3/8	27 5/8	28 5/8	71	80	-	-	-	-	-	-
CRI 3-11	2	1	115-230	56C	16 7/8	17 7/8	7 1/4	5 3/4	29 1/2	30 1/2	70	78	-	-	-	-	-	-
		3	208-230/460	56C	16 7/8	17 7/8	7 1/8	4 3/8	28 3/8	29 3/8	72	81	-	-	-	-	-	-
CRI(E) 3-12	2	1	115-230	56C	17 1/2	18 1/2	7 1/4	5 3/4	30 1/8	31 1/8	71	79	-	-	-	-	-	-
		3	208-230/460	56C	17 1/2	18 1/2	7 1/8	4 3/8	29	30	73	82	7	6 5/8	29	30	91	101
CRI 3-13	3	1	115/208-230	182TC	19 3/8	20 1/4	8 5/8	6 7/8	33 7/8	34 3/4	88	96	-	-	-	-	-	-
		3	208-230/460	182TC	19 3/8	20 1/4	7 1/8	4 3/8	31 1/8	32	75	83	-	-	-	-	-	-
CRI(E) 3-15	3	1	115/208-230	182TC	20 3/4	21 3/4	8 5/8	6 7/8	35 1/4	36 1/4	89	97	-	-	-	-	-	-
		3	208-230/460	182TC	20 3/4	21 3/4	7 1/8	4 3/8	32 1/2	33 1/2	76	84	7	6 5/8	34 1/8	35 1/8	104	113
CRI 3-17	3	1	115/208-230	182TC	22 1/8	23 1/8	8 5/8	6 7/8	36 5/8	37 5/8	90	99	-	-	-	-	-	-
		3	208-230/460	182TC	22 1/8	23 1/8	7 1/8	4 3/8	33 7/8	34 7/8	77	86	-	-	-	-	-	-
CRI 3-19	3	1	115/208-230	182TC	-	24 1/2	8 5/8	6 7/8	-	39	-	100	-	-	-	-	-	-
		3	208-230/460	182TC	-	24 1/2	7 1/8	4 3/8	-	36 1/4	-	87	-	-	-	-	-	-
CRI 3-21	5	1	208-230	182TC	-	26	10 5/8	7 1/2	-	41 3/8	-	109	-	-	-	-	-	-
		3	208-230/460	182TC	-	26	7 1/8	4 3/8	-	39 1/4	-	88	-	-	-	-	-	-
CRI 3-23	5	1	208-230	182TC	-	27 3/8	10 5/8	7 1/2	-	42 3/4	-	111	-	-	-	-	-	-
		3	208-230/460	182TC	-	27 3/8	7 1/8	4 3/8	-	40 5/8	-	90	-	-	-	-	-	-
CRI 3-25	5	1	208-230	182TC	-	28 3/4	10 5/8	7 1/2	-	44 1/8	-	114	-	-	-	-	-	-
		3	208-230/460	182TC	-	28 3/4	7 1/8	4 3/8	-	42	-	92	-	-	-	-	-	-

Weights are based on pump with TEFC motor (see price list for individual weights)
All dimensions in inches unless otherwise noted.

Dimensional sketches

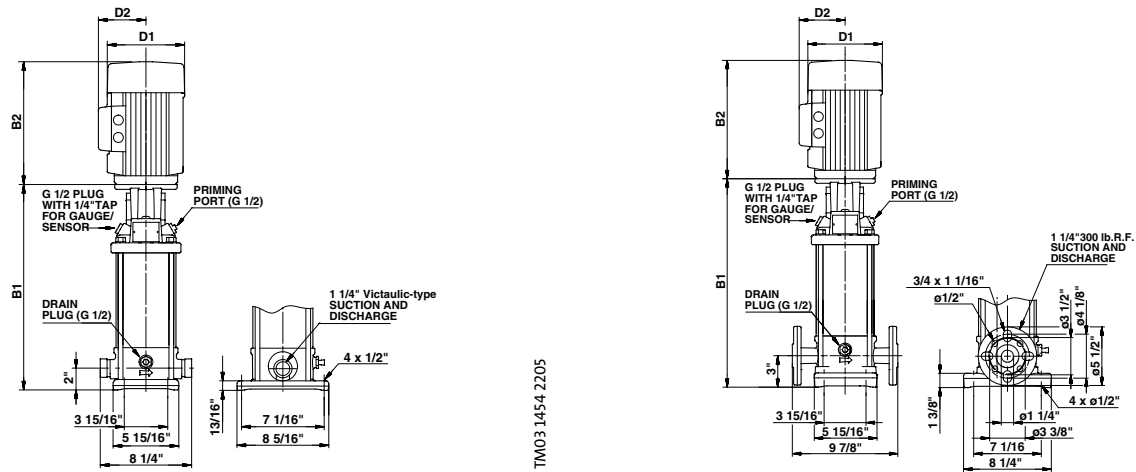

TM03 1454 2205

TM03 1453 2205

Dimensions and weights

Pump type	Hp	Ph	Voltage	NEMA Frame size	PJE B1	ANSI B1	TEFC				PJE Ship Wt. ¹ [lbs.]	ANSI Ship Wt. ¹ [lbs.]	MLE				PJE Ship Wt. ¹ [lbs.]	ANSI Ship Wt. ¹ [lbs.]
							D1	D2	PJE B1+B2	ANSI B1+B2			D1	D2	PJE B1+B2	ANSI B1+B2		
CRN 3-2	1/3	1	115/230	56C	11 1/8	12 1/8	6 1/4	5	20 1/2	21 1/2	47	55	-	-	-	-	-	-
		3	208-230/460	56C	11 1/8	12 1/8	5 5/8	4 5/8	18 3/4	19 3/4	47	55	-	-	-	-	-	-
CRN(E) 3-3	1/2	1	115/230	56C	11 1/8	12 1/8	6 1/4	5	20 1/2	21 1/2	46	54	5 1/2	5 1/2	18 5/8	19 5/8	47	56
		3	208-230/460	56C	11 1/8	12 1/8	5 5/8	4 5/8	18 3/4	19 3/4	47	55	-	-	-	-	-	-
CRN 3-4	3/4	1	115/208-230	56C	11 7/8	12 7/8	6 1/4	5	21 7/8	22 7/8	48	56	-	-	-	-	-	-
		3	208-230/460	56C	11 7/8	12 7/8	5 5/8	4 5/8	19 1/2	20 1/2	47	55	-	-	-	-	-	-
CRN(E) 3-5	3/4	1	115/208-230	56C	12 5/8	13 5/8	6 1/4	5	22 5/8	23 5/8	49	57	5 1/2	5 1/2	20 1/8	21 1/8	50	58
		3	208-230/460	56C	12 5/8	13 5/8	5 5/8	4 5/8	20 1/4	21 1/4	48	56	-	-	-	-	-	-
CRN(E) 3-6	1	1	115-230	56C	13 1/4	14 1/4	7 1/4	5 3/4	24 1/2	25 1/2	51	59	5 1/2	5 1/2	22 3/8	23 3/8	53	63
		3	208-230/460	56C	13 1/4	14 1/4	5 5/8	4 5/8	22 1/8	23 1/8	48	56	7	6 5/8	24 3/4	25 3/4	66	75
CRN 3-7	1 1/2	1	115/208-230	56C	14	15	7 1/4	5 3/4	25 3/4	26 3/4	59	68	-	-	-	-	-	-
		3	208-230/460	56C	14	15	5 5/8	4 5/8	22 7/8	23 7/8	49	59	-	-	-	-	-	-
CRN 3-8	1 1/2	1	115/208-230	56C	14 3/4	15 3/4	7 1/4	5 3/4	26 1/2	27 1/2	61	71	-	-	-	-	-	-
		3	208-230/460	56C	14 3/4	15 3/4	5 5/8	4 5/8	23 5/8	24 5/8	50	60	-	-	-	-	-	-
CRN(E) 3-9	1 1/2	1	115/208-230	56C	15 3/8	16 3/8	7 1/4	5 3/4	27 1/8	28 1/8	62	72	5 1/2	5 1/2	24 1/2	25 1/2	62	71
		3	208-230/460	56C	15 3/8	16 3/8	5 5/8	4 5/8	24 1/4	25 1/4	51	61	7	6 5/8	26 7/8	27 7/8	74	84
CRN 3-10	2	1	115-230	56C	16 1/8	17 1/8	7 1/4	5 3/4	28 3/4	29 3/4	69	77	-	-	-	-	-	-
		3	208-230/460	56C	16 1/8	17 1/8	7 1/8	4 3/8	27 5/8	28 5/8	72	80	-	-	-	-	-	-
CRN 3-11	2	1	115-230	56C	16 7/8	17 7/8	7 1/4	5 3/4	29 1/2	30 1/2	70	78	-	-	-	-	-	-
		3	208-230/460	56C	16 7/8	17 7/8	7 1/8	4 3/8	28 3/8	29 3/8	73	81	-	-	-	-	-	-
CRN(E) 3-12	2	1	115-230	56C	17 1/2	18 1/2	7 1/4	5 3/4	30 1/8	31 1/8	72	79	-	-	-	-	-	-
		3	208-230/460	56C	17 1/2	18 1/2	7 1/8	4 3/8	29	30	74	82	7	6 5/8	29	30	91	101
CRN 3-13	3	1	115/208-230	182TC	19 3/8	20 1/4	8 5/8	6 7/8	33 7/8	34 3/4	88	96	-	-	-	-	-	-
		3	208-230/460	182TC	19 3/8	20 1/4	7 1/8	4 3/8	31 1/8	32	75	83	-	-	-	-	-	-
CRN(E) 3-15	3	1	115/208-230	182TC	20 3/4	21 3/4	8 5/8	6 7/8	35 1/4	36 1/4	90	97	-	-	-	-	-	-
		3	208-230/460	182TC	20 3/4	21 3/4	7 1/8	4 3/8	32 1/2	33 1/2	77	84	7	6 5/8	34 1/8	35 1/8	104	113
CRN 3-17	3	1	115/208-230	182TC	22 1/8	23 1/8	8 5/8	6 7/8	36 5/8	37 5/8	91	99	-	-	-	-	-	-
		3	208-230/460	182TC	22 1/8	23 1/8	7 1/8	4 3/8	33 7/8	34 7/8	78	86	-	-	-	-	-	-
CRN(E) 3-19	3	1	115/208-230	182TC	23 5/8	24 1/2	8 5/8	6 7/8	38 1/8	39	92	100	-	-	-	-	-	-
		3	208-230/460	182TC	23 5/8	24 1/2	7 1/8	4 3/8	35 3/8	36 1/4	79	87	7	6 5/8	37	38	115	
CRN 3-21	5	1	208-230	182TC	25	26	10 5/8	7 1/2	40 3/8	41 3/8	101	109	-	-	-	-	-	-
		3	208-230/460	182TC	25	26	7 1/8	4 3/8	38 1/4	39 1/4	80	88	-	-	-	-	-	-
CRN 3-23	5	1	208-230	182TC	26 3/8	27 3/8	10 5/8	7 1/2	41 3/4	42 3/4	103	111	-	-	-	-	-	-
		3	208-230/460	182TC	26 3/8	27 3/8	7 1/8	4 3/8	39 5/8	40 5/8	82	90	-	-	-	-	-	-
CRN(E) 3-25	5	1	208-230	182TC	27 7/8	28 3/4	10 5/8	7 1/2	43 1/4	44 1/8	106	114	-	-	-	-	-	-
		3	208-230/460	182TC	27 7/8	28 3/4	7 1/8	4 3/8	41 1/8	42	84	92	8 3/4	7 1/2	43 3/8	44 3/8	155	

Weights are based on pump with TEFC motor (see price list for individual weights)
All dimensions in inches unless otherwise noted.

Performance curves

CR(E) 5, CRI(E) 5, CRN(E) 5

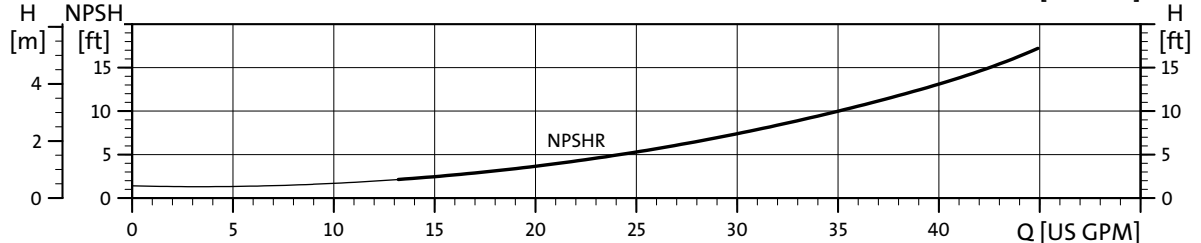
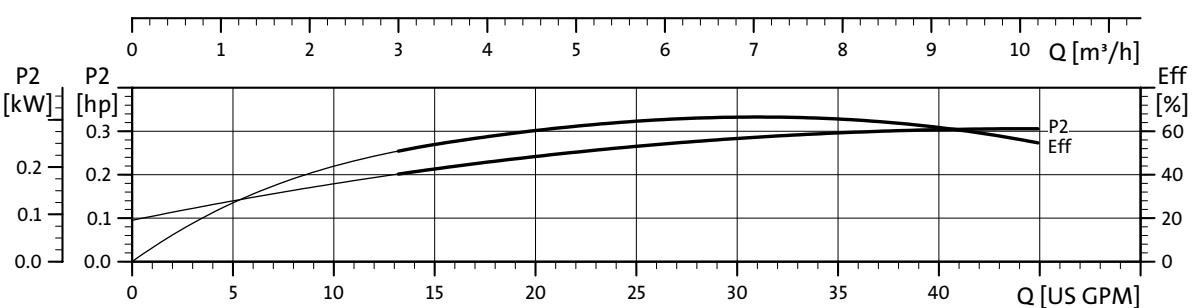
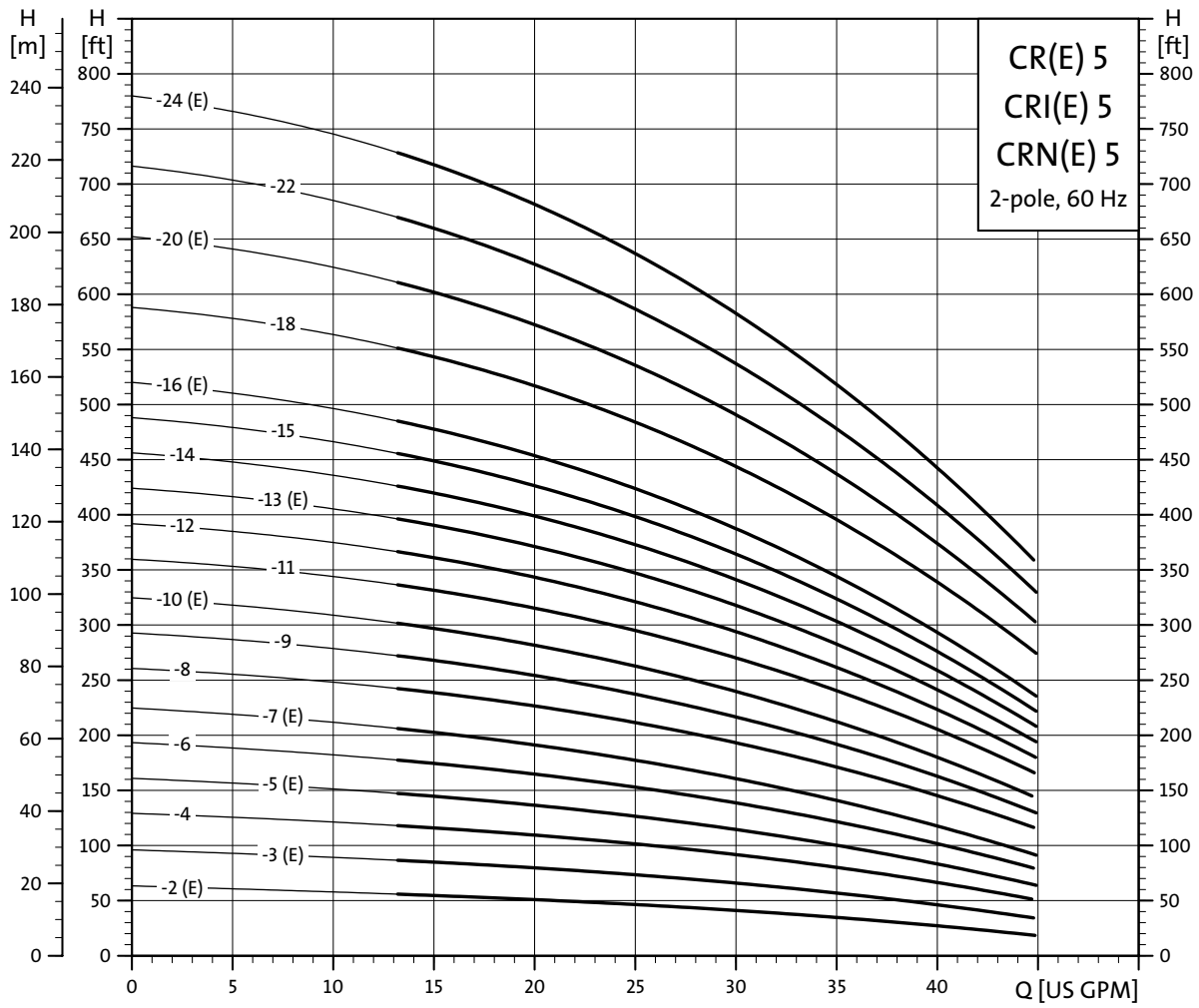

TM02 40851303

Dimensional sketches

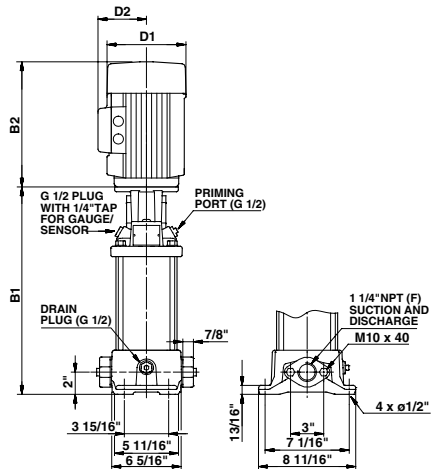

TM03 1455 2205

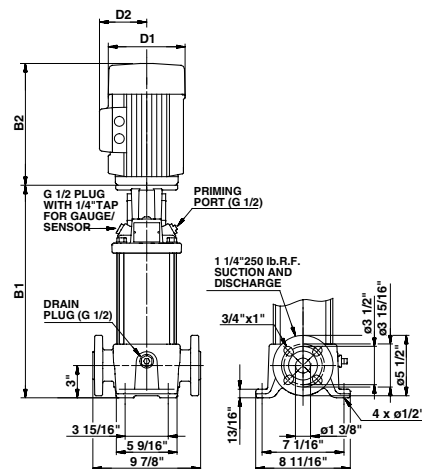

TM03 1451 2205

Dimensions and weights

Pump type	Hp	Ph	Voltage	NEMA Frame size	Oval B1	ANSI B1	TEFC				Oval Ship Wt. ¹ [lbs.]	ANSI Ship Wt. ¹ [lbs.]	MLE				Oval Ship Wt. ¹ [lbs.]	ANSI Ship Wt. ¹ [lbs.]
							D1	D2	Oval B1+B2	ANSI B1+B2			D1	D2	Oval B1+B2	ANSI B1+B2		
CR(E) 5-2	3/4	1	115/208-230	56C	11	12	6 1/4	5	21	22	54	63	5 1/2	5 1/2	18 1/2	19 1/2	55	64
		3	208-230/460	56C	11	12	5 5/8	4 5/8	18 5/8	19 5/8	53	62	-	-	-	-	-	-
CR(E) 5-3	1	1	115-230	56C	12 1/8	13 1/8	7 1/4	5 3/4	23 3/8	24 3/8	57	66	5 1/2	5 1/2	21 1/4	22 1/4	59	68
		3	208-230/460	56C	12 1/8	13 1/8	5 5/8	4 5/8	21	22	53	62	7	6 5/8	23 5/8	24 5/8	72	81
CR 5-4	1 1/2	1	115/208-230	56C	13 1/8	14 1/8	7 1/4	5 3/4	24 7/8	25 7/8	64	73	-	-	-	-	-	-
		3	208-230/460	56C	13 1/8	14 1/8	5 5/8	4 5/8	22	23	62	69	-	-	-	-	-	-
CR(E) 5-5	1 1/2	1	115/208-230	56C	14 1/4	15 1/4	7 1/4	5 3/4	26	27	66	76	5 1/2	5 1/2	23 3/8	24 3/8	66	77
		3	208-230/460	56C	14 1/4	15 1/4	5 5/8	4 5/8	23 1/8	24 1/8	63	70	7	6 5/8	25 3/4	26 3/4	78	88
CR 5-6	2	1	115-230	56C	15 1/4	16 1/4	7 1/4	5 3/4	27 7/8	28 7/8	73	83	-	-	-	-	-	-
		3	208-230/460	56C	15 1/4	16 1/4	7 1/8	4 3/8	26 3/4	27 3/4	76	86	-	-	-	-	-	-
CR(E) 5-7	2	1	115-230	56C	16 3/8	17 3/8	7 1/4	5 3/4	29	30	76	85	-	-	-	-	-	-
		3	208-230/460	56C	16 3/8	17 3/8	7 1/8	4 3/8	27 7/8	28 7/8	78	87	7	6 5/8	27 7/8	28 7/8	97	106
CR 5-8	3	1	115/208-230	182TC	18 1/2	19 1/2	8 5/8	6 7/8	33	34	94	103	-	-	-	-	-	-
		3	208-230/460	182TC	18 1/2	19 1/2	7 1/8	4 3/8	30 1/4	31 1/4	81	90	-	-	-	-	-	-
CR 5-9	3	1	115/208-230	182TC	19 1/2	20 1/2	8 5/8	6 7/8	34	35	95	104	-	-	-	-	-	-
		3	208-230/460	182TC	19 1/2	20 1/2	7 1/8	4 3/8	31 1/4	32 1/4	82	91	-	-	-	-	-	-
CR(E) 5-10	3	1	115/208-230	182TC	20 5/8	21 5/8	8 5/8	6 7/8	35 1/8	36 1/8	96	105	-	-	-	-	-	-
		3	208-230/460	182TC	20 5/8	21 5/8	7 1/8	4 3/8	32 3/8	33 3/8	83	92	7	6 5/8	34	35	111	120
CR 5-11	5	1	208-230	182TC	21 5/8	22 5/8	10 5/8	7 1/2	37	38	103	112	-	-	-	-	-	-
		3	208-230/460	182TC	21 5/8	22 5/8	7 1/8	4 3/8	34 7/8	35 7/8	81	90	-	-	-	-	-	-
CR 5-12	5	1	208-230	182TC	22 3/4	23 3/4	10 5/8	7 1/2	38 1/8	39 1/8	104	113	-	-	-	-	-	-
		3	208-230/460	182TC	22 3/4	23 3/4	7 1/8	4 3/8	36	37	82	91	-	-	-	-	-	-
CR(E) 5-13	5	1	208-230	182TC	23 3/4	24 3/4	10 5/8	7 1/2	39 1/8	40 1/8	105	115	-	-	-	-	-	-
		3	208-230/460	182TC	23 3/4	24 3/4	7 1/8	4 3/8	37	38	83	94	8 3/4	7 1/2	39 1/4	40 1/4	146	156
CR 5-14	5	1	208-230	182TC	24 7/8	25 7/8	10 5/8	7 1/2	40 1/4	41 1/4	107	116	-	-	-	-	-	-
		3	208-230/460	182TC	24 7/8	25 7/8	7 1/8	4 3/8	38 1/8	39 1/8	86	95	-	-	-	-	-	-
CR 5-15	5	1	208-230	182TC	25 7/8	26 7/8	10 5/8	7 1/2	41 1/4	42 1/4	109	118	-	-	-	-	-	-
		3	208-230/460	182TC	25 7/8	26 7/8	7 1/8	4 3/8	39 1/8	40 1/8	87	96	-	-	-	-	-	-
CR(E) 5-16	5	1	208-230	182TC	27	28	10 5/8	7 1/2	42 3/8	43 3/8	110	119	-	-	-	-	-	-
		3	208-230/460	182TC	27	28	7 1/8	4 3/8	40 1/4	41 1/4	89	98	8 3/4	7 1/2	42 1/2	43 1/2	151	160
CR 5-18	7 1/2	1	208-230	213TC	-	30 1/2	10 1/4	7 1/2	-	45 7/8	-	152	-	-	-	-	-	-
		3	208-230/460	213TC	-	30 1/2	8 3/4	5 3/8	-	46 1/8	-	164	-	-	-	-	-	-
CR(E) 5-20	7 1/2	1	208-230	213TC	-	32 5/8	10 1/4	7 1/2	-	48	-	154	-	-	-	-	-	-
		3	208-230/460	213TC	-	32 5/8	8 3/4	5 3/8	-	48 1/4	-	166	8 3/4	7 1/2	-	48 1/8	-	173
CR 5-22	7 1/2	1	208-230	213TC	-	34 3/4	10 1/4	7 1/2	-	50 1/8	-	157	-	-	-	-	-	-
		3	208-230/460	213TC	-	34 3/4	8 3/4	5 3/8	-	50 3/8	-	169	-	-	-	-	-	-
CR(E) 5-24	7 1/2	1	208-230	213TC	-	36 7/8	10 1/4	7 1/2	-	52 1/4	-	161	-	-	-	-	-	-
		3	208-230/460	213TC	-	36 7/8	8 3/4	5 3/8	-	52 1/2	-	173	8 3/4	7 1/2	-	52 3/8	-	180

Weights are based on pump with TEFC motor (see price list for individual weights)
All dimensions in inches unless otherwise noted.

Dimensional sketches

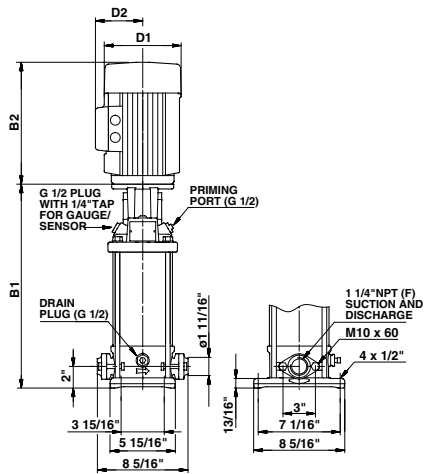

TM03 1456 2205

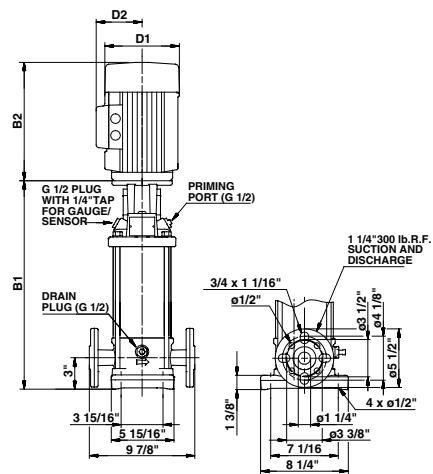

TM03 1456 2205

Dimensions and weights

Pump type	Hp	Ph	Voltage	NEMA Frame size	Oval B1	ANSI B1	TEFC				Oval Ship Wt. ¹ [lbs.]	ANSI Ship Wt. ¹ [lbs.]	MLE				Oval Ship Wt. ¹ [lbs.]	ANSI Ship Wt. ¹ [lbs.]
							D1	D2	Oval B1+B2	ANSI B1+B2			D1	D2	Oval B1+B2	ANSI B1+B2		
CRI(E) 5-2	3/4	1	115/208-230	56C	11 1/8	12 1/8	6 1/4	5	21 1/8	22 1/8	47	56	5 1/2	5 1/2	18 5/8	19 5/8	49	57
		3	208-230/460	56C	11 1/8	12 1/8	5 5/8	4 5/8	18 3/4	19 3/4	46	55	-	-	-	-	-	-
CRI(E) 5-3	1	1	115-230	56C	12 1/4	13 1/4	7 1/4	5 3/4	23 1/2	24 1/2	50	58	5 1/2	5 1/2	21 3/8	22 3/8	52	61
		3	208-230/460	56C	12 1/4	13 1/4	5 5/8	4 5/8	21 1/8	22 1/8	46	55	7	6 5/8	23 3/4	24 3/4	65	74
CRI 5-4	1 1/2	1	115/208-230	56C	13 1/4	14 1/4	7 1/4	5 3/4	25	26	57	65	-	-	-	-	-	-
		3	208-230/460	56C	13 1/4	14 1/4	5 5/8	4 5/8	22 1/8	23 1/8	53	58	-	-	-	-	-	-
CRI(E) 5-5	1 1/2	1	115/208-230	56C	14 3/8	15 3/8	7 1/4	5 3/4	26 1/8	27 1/8	59	69	5 1/2	5 1/2	23 1/2	24 1/2	60	69
		3	208-230/460	56C	14 3/8	15 3/8	5 5/8	4 5/8	23 1/4	24 1/4	52	62	7	6 5/8	25 7/8	26 7/8	71	81
CRI 5-6	2	1	115-230	56C	15 3/8	16 3/8	7 1/4	5 3/4	28	29	66	76	-	-	-	-	-	-
		3	208-230/460	56C	15 3/8	16 3/8	7 1/8	4 3/8	26 7/8	27 7/8	69	79	-	-	-	-	-	-
CRI(E) 5-7	2	1	115-230	56C	16 1/2	17 1/2	7 1/4	5 3/4	29 1/8	30 1/8	69	78	-	-	-	-	-	-
		3	208-230/460	56C	16 1/2	17 1/2	7 1/8	4 3/8	28	29	72	80	7	6 5/8	28	29	90	98
CRI 5-8	3	1	115/208-230	182TC	18 5/8	19 5/8	8 5/8	6 7/8	33 1/8	34 1/8	87	96	-	-	-	-	-	-
		3	208-230/460	182TC	18 5/8	19 5/8	7 1/8	4 3/8	30 3/8	31 3/8	84	83	-	-	-	-	-	-
CRI 5-9	3	1	115/208-230	182TC	19 5/8	20 5/8	8 5/8	6 7/8	34 1/8	35 1/8	88	97	-	-	-	-	-	-
		3	208-230/460	182TC	19 5/8	20 5/8	7 1/8	4 3/8	31 3/8	32 3/8	75	84	-	-	-	-	-	-
CRI(E) 5-10	3	1	115/208-230	182TC	20 3/4	21 3/4	8 5/8	6 7/8	35 1/4	36 1/4	89	97	-	-	-	-	-	-
		3	208-230/460	182TC	20 3/4	21 3/4	7 1/8	4 3/8	32 1/2	33 1/2	76	84	7	6 5/8	34 1/8	35 1/8	104	113
CRI 5-11	5	1	208-230	182TC	21 3/4	22 3/4	10 5/8	7 1/2	37 1/8	38 1/8	96	104	-	-	-	-	-	-
		3	208-230/460	182TC	21 3/4	22 3/4	7 1/8	4 3/8	35	36	74	83	-	-	-	-	-	-
CRI 5-12	5	1	208-230	182TC	22 7/8	23 7/8	10 5/8	7 1/2	38 1/4	39 1/4	97	105	-	-	-	-	-	-
		3	208-230/460	182TC	22 7/8	23 7/8	7 1/8	4 3/8	36 1/8	37 1/8	75	84	-	-	-	-	-	-
CRI(E) 5-13	5	1	208-230	182TC	23 7/8	24 7/8	10 5/8	7 1/2	39 1/4	40 1/4	98	108	-	-	-	-	-	-
		3	208-230/460	182TC	23 7/8	24 7/8	7 1/8	4 3/8	37 1/8	38 1/8	77	86	8 3/4	7 1/2	39 3/8	40 3/8	139	149
CRI 5-14	5	1	208-230	182TC	25	26	10 5/8	7 1/2	40 3/8	41 3/8	101	109	-	-	-	-	-	-
		3	208-230/460	182TC	25	26	7 1/8	4 3/8	38 1/4	39 1/4	79	88	-	-	-	-	-	-
CRI 5-15	5	1	208-230	182TC	26	27	10 5/8	7 1/2	41 3/8	42 3/8	102	111	-	-	-	-	-	-
		3	208-230/460	182TC	26	27	7 1/8	4 3/8	39 1/4	40 1/4	80	89	-	-	-	-	-	-
CRI(E) 5-16	5	1	208-230	182TC	27 1/8	28 1/8	10 5/8	7 1/2	42 1/2	43 1/2	103	112	-	-	-	-	-	-
		3	208-230/460	182TC	27 1/8	28 1/8	7 1/8	4 3/8	40 3/8	41 3/8	82	90	8 3/4	7 1/2	42 5/8	43 5/8	144	153
CRI 5-18	7 1/2	1	208-230	213TC	-	30 5/8	10 1/4	7 1/2	15 3/8	46	-	144	-	-	-	-	-	-
		3	208-230/460	213TC	-	30 5/8	8 3/4	5 3/8	15 5/8	46 1/4	-	156	-	-	-	-	-	-
CRI 5-20	7 1/2	1	208-230	213TC	-	32 3/4	10 1/4	7 1/2	15 3/8	48 1/8	-	147	-	-	-	-	-	-
		3	208-230/460	213TC	-	32 3/4	8 3/4	5 3/8	15 5/8	48 3/8	-	159	-	-	-	-	-	-
CRI 5-22	7 1/2	1	208-230	213TC	-	34 7/8	10 1/4	7 1/2	15 3/8	50 1/4	-	149	-	-	-	-	-	-
		3	208-230/460	213TC	-	34 7/8	8 3/4	5 3/8	15 5/8	50 1/2	-	161	-	-	-	-	-	-
CRI 5-24	7 1/2	1	208-230	213TC	-	37	10 1/4	7 1/2	15 3/8	52 3/8	-	154	-	-	-	-	-	-
		3	208-230/460	213TC	-	37	8 3/4	5 3/8	15 5/8	52 5/8	-	166	-	-	-	-	-	-

Weights are based on pump with TEFC motor (see price list for individual weights)
All dimensions in inches unless otherwise noted.

Dimensional sketches

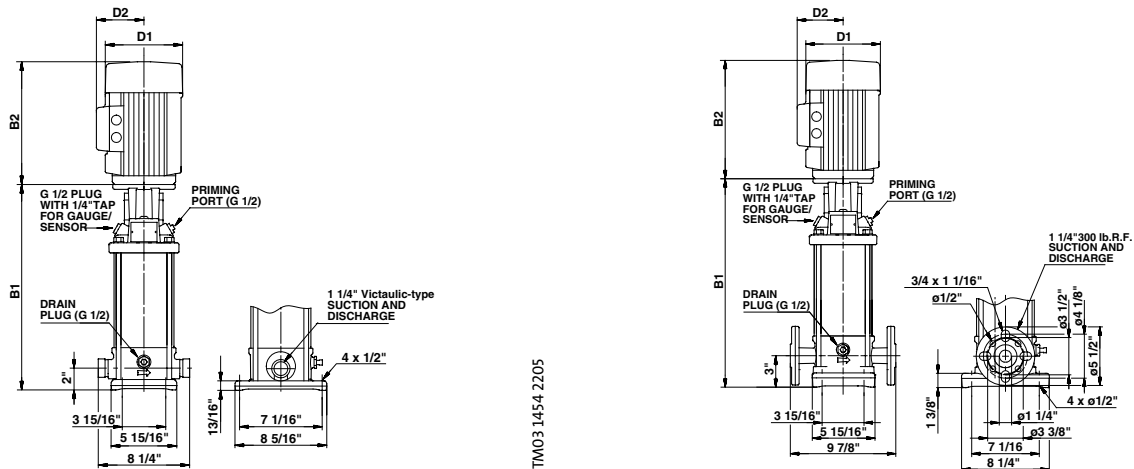

Dimensions and weights

Pump type	Hp	Ph	Voltage	NEMA Frame size	PJE B1	ANSI B1	TEFC				PJE Ship Wt. ¹ [lbs.]	ANSI Ship Wt. ¹ [lbs.]	MLE				PJE Ship Wt. ¹ [lbs.]	ANSI Ship Wt. ¹ [lbs.]
							D1	D2	PJE B1+B2	ANSI B1+B2			D1	D2	PJE B1+B2	ANSI B1+B2		
CRN(E) 5-2	3/4	1	115/208-230	56C	11 1/8	12 1/8	6 1/4	5	21 1/8	22 1/8	48	56	5 1/2	5 1/2	18 5/8	19 5/8	49	57
		3	208-230/460	56C	11 1/8	12 1/8	5 5/8	4 5/8	18 3/4	19 3/4	47	55	-	-	-	-	-	-
CRN(E) 5-3	1	1	115-230	56C	12 1/4	13 1/4	7 1/4	5 3/4	23 1/2	24 1/2	50	58	5 1/2	5 1/2	21 3/8	22 3/8	52	61
		3	208-230/460	56C	12 1/4	13 1/4	5 5/8	4 5/8	21 1/8	22 1/8	47	55	7	6 5/8	23 5/8	24 5/8	65	74
CRN 5-4	1 1/2	1	115/208-230	56C	13 1/4	14 1/4	7 1/4	5 3/4	25	26	57	65	-	-	-	-	-	-
		3	208-230/460	56C	13 1/4	14 1/4	5 5/8	4 5/8	22 1/8	23 1/8	54	61	-	-	-	-	-	-
CRN(E) 5-5	1 1/2	1	115/208-230	56C	14 3/8	15 3/8	7 1/4	5 3/4	26 1/8	27 1/8	60	69	5 1/2	5 1/2	23 1/2	24 1/2	60	69
		3	208-230/460	56C	14 3/8	15 3/8	5 5/8	4 5/8	23 1/4	24 1/4	55	63	7	6 5/8	25 7/8	26 7/8	71	81
CRN 5-6	2	1	115-230	56C	15 3/8	16 3/8	7 1/4	5 3/4	28	29	67	76	-	-	-	-	-	-
		3	208-230/460	56C	15 3/8	16 3/8	7 1/8	4 3/8	26 7/8	27 7/8	70	79	-	-	-	-	-	-
CRN(E) 5-7	2	1	115-230	56C	16 1/2	17 1/2	7 1/4	5 3/4	29 1/8	30 1/8	70	78	-	-	-	-	-	-
		3	208-230/460	56C	16 1/2	17 1/2	7 1/8	4 3/8	28	29	72	80	7	6 5/8	28	29	90	98
CRN 5-8	3	1	115/208-230	182TC	18 5/8	19 5/8	8 5/8	6 7/8	33 1/8	34 1/8	88	96	-	-	-	-	-	-
		3	208-230/460	182TC	18 5/8	19 5/8	7 1/8	4 3/8	30 3/8	31 3/8	75	83	-	-	-	-	-	-
CRN 5-9	3	1	115/208-230	182TC	19 5/8	20 5/8	8 5/8	6 7/8	34 1/8	35 1/8	89	97	-	-	-	-	-	-
		3	208-230/460	182TC	19 5/8	20 5/8	7 1/8	4 3/8	31 3/8	32 3/8	76	84	-	-	-	-	-	-
CRN(E) 5-10	3	1	115/208-230	182TC	20 3/4	21 3/4	8 5/8	6 7/8	35 1/4	36 1/4	90	97	-	-	-	-	-	-
		3	208-230/460	182TC	20 3/4	21 3/4	7 1/8	4 3/8	32 1/2	33 1/2	77	84	7	6 5/8	34 1/8	35 1/8	104	113
CRN 5-11	5	1	208-230	182TC	21 3/4	22 3/4	10 5/8	7 1/2	37 1/8	38 1/8	97	104	-	-	-	-	-	-
		3	208-230/460	182TC	21 3/4	22 3/4	7 1/8	4 3/8	35	36	75	83	-	-	-	-	-	-
CRN 5-12	5	1	208-230	182TC	22 7/8	23 7/8	10 5/8	7 1/2	38 1/4	39 1/4	97	105	-	-	-	-	-	-
		3	208-230/460	182TC	22 7/8	23 7/8	7 1/8	4 3/8	36 1/8	37 1/8	76	84	-	-	-	-	-	-
CRN(E) 5-13	5	1	208-230	182TC	23 7/8	24 7/8	10 5/8	7 1/2	39 1/4	40 1/4	99	108	-	-	-	-	-	-
		3	208-230/460	182TC	23 7/8	24 7/8	7 1/8	4 3/8	37 1/8	38 1/8	77	86	8 3/4	7 1/2	39 3/8	40 3/8	139	149
CRN 5-14	5	1	208-230	182TC	25	26	10 5/8	7 1/2	40 3/8	41 3/8	101	109	-	-	-	-	-	-
		3	208-230/460	182TC	25	26	7 1/8	4 3/8	38 1/4	39 1/4	80	88	-	-	-	-	-	-
CRN 5-15	5	1	208-230	182TC	26	27	10 5/8	7 1/2	41 3/8	42 3/8	103	111	-	-	-	-	-	-
		3	208-230/460	182TC	26	27	7 1/8	4 3/8	39 1/4	40 1/4	81	89	-	-	-	-	-	-
CRN(E) 5-16	5	1	208-230	182TC	27 1/8	28 1/8	10 5/8	7 1/2	42 1/2	43 1/2	104	112	-	-	-	-	-	-
		3	208-230/460	182TC	27 1/8	28 1/8	7 1/8	4 3/8	40 3/8	41 3/8	83	90	8 3/4	7 1/2	42 5/8	43 5/8	144	153
CRN 5-18	7 1/2	1	208-230	213TC	29 5/8	30 5/8	10 1/4	7 1/2	45	46	136	144	-	-	-	-	-	-
		3	208-230/460	213TC	29 5/8	30 5/8	8 3/4	5 3/8	45 1/4	46 1/4	148	156	-	-	-	-	-	-
CRN(E) 5-20	7 1/2	1	208-230	213TC	31 3/4	32 3/4	10 1/4	7 1/2	47 1/8	48 1/8	139	147	-	-	-	-	-	-
		3	208-230/460	213TC	31 3/4	32 3/4	8 3/4	5 3/8	47 3/8	48 3/8	151	159	8 3/4	7 1/2	47 1/4	48 1/4	157	165
CRN 5-22	7 1/2	1	208-230	213TC	33 7/8	34 7/8	10 1/4	7 1/2	49 1/4	50 1/4	142	149	-	-	-	-	-	-
		3	208-230/460	213TC	33 7/8	34 7/8	8 3/4	5 3/8	49 1/2	50 1/2	153	161	-	-	-	-	-	-
CRN(E) 5-24	7 1/2	1	208-230	213TC	36	37	10 1/4	7 1/2	51 3/8	52 3/8	146	154	-	-	-	-	-	-
		3	208-230/460	213TC	36	37	8 3/4	5 3/8	51 5/8	52 5/8	158	166	8 3/4	7 1/2	51 2/5	51 1/2	53	172

Weights are based on pump with TEFC motor (see price list for individual weights)
All dimensions in inches unless otherwise noted.

Performance curves

CR(E), CRI(E), CRN(E) 10

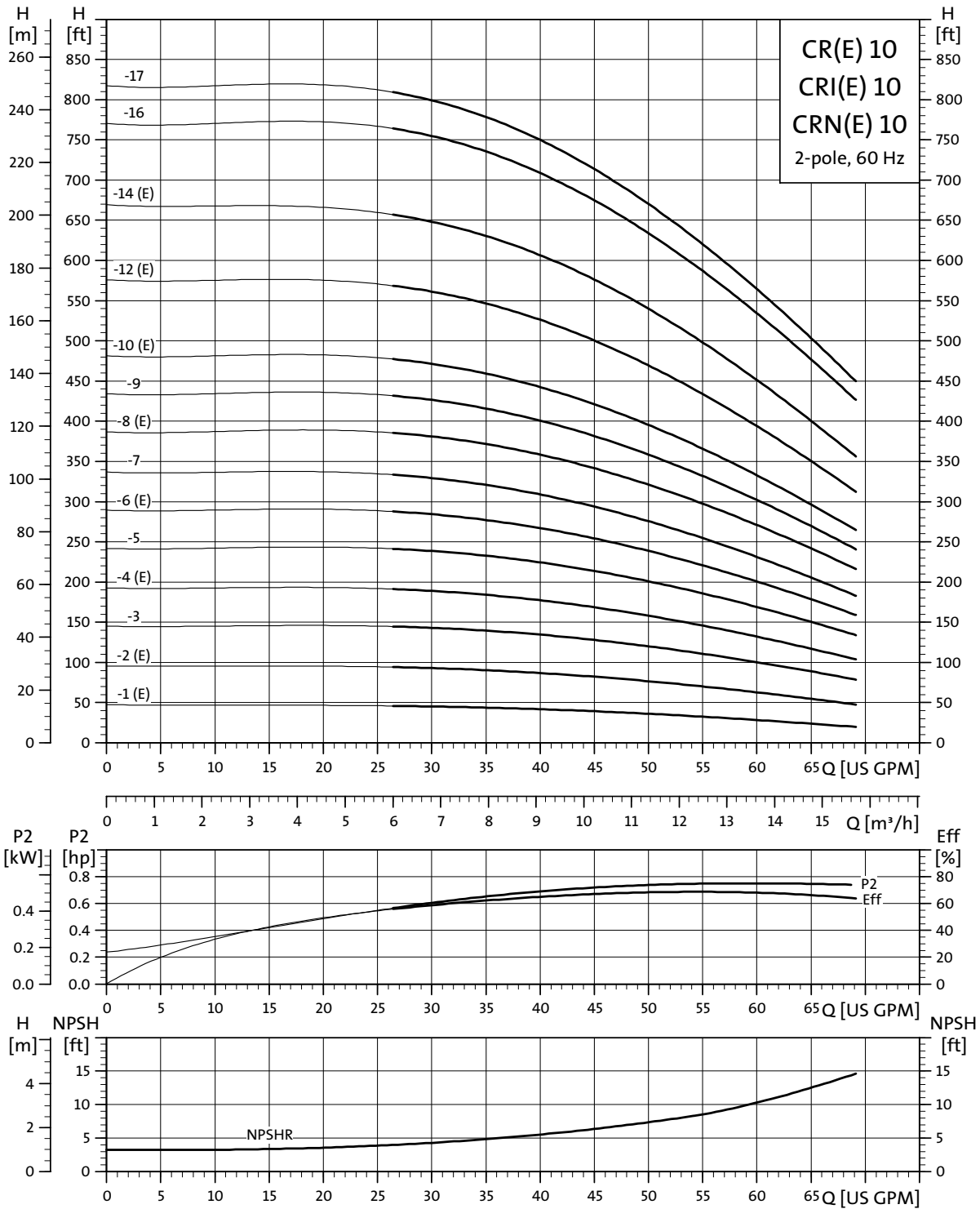

TM02 7221 3704

Dimensional sketches

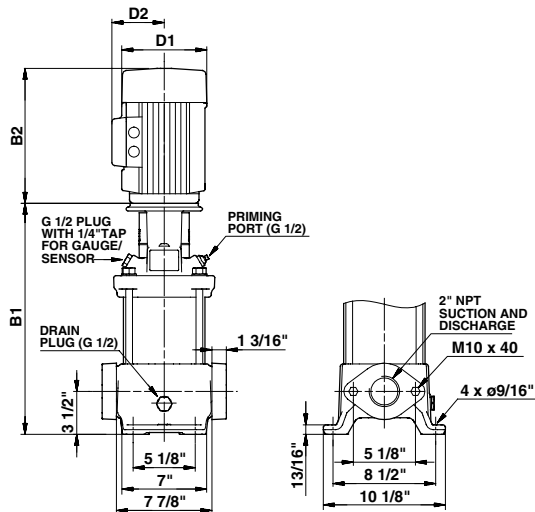

TM03 1460 2205

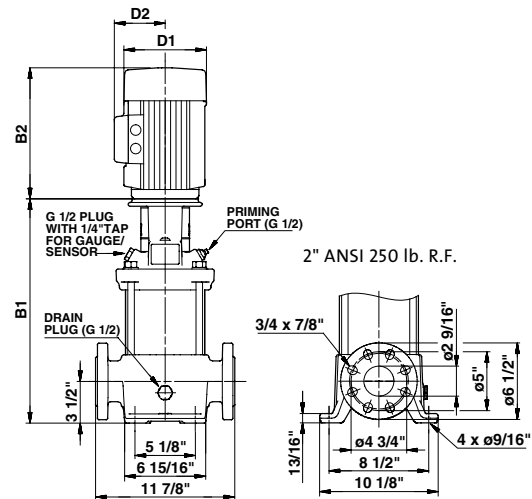

TM03 1461 2205

Dimensions and weights

Pump type	Hp	Ph	Voltage	NEMA Frame size	Oval B1	ANSI B1	TEFC				ODP				Oval Ship Wt. ¹ [lbs.]	ANSI Ship Wt. ¹ [lbs.]	MLE				Oval Ship Wt. ¹ [lbs.]	ANSI Ship Wt. ¹ [lbs.]
							D1	D2	Oval B1+B2	ANSI B1+B2	D1	D2	Oval B1+B2	ANSI B1+B2			D1	D2	Oval B1+B2	ANSI B1+B2		
CR(E) 10-1	3/4	1	115/208-230	56C	15 1/4	15 1/4	6 1/4	5	25 1/4	25 1/4	-	-	-	-	97	103	5 1/2	5 1/2	22 7/8	22 7/8	90	92
			208-230/460	56C	15 1/4	15 1/4	5 5/8	4 5/8	24 1/8	24 1/8	-	-	-	-	79	85	-	-	-	-	-	-
CR(E) 10-2	1 1/2	3	115/208-230	56C	15 1/4	15 1/4	7 1/4	5 3/4	27	27	-	-	-	-	112	119	5 1/2	5 1/2	24 1/2	24 1/2	108	111
			208-230/460	56C	15 1/4	15 1/4	5 5/8	4 5/8	24 1/8	24 1/8	-	-	-	-	94	100	7	6 5/8	26 7/8	26 7/8	121	123
CR 10-3	3	3	115/208-230	182TC	17 1/8	17 1/8	8 5/8	6 7/8	31 5/8	31 5/8	-	-	-	-	163	169	-	-	-	-	-	-
			208-230/460	182TC	17 1/8	17 1/8	7 1/8	4 3/8	28 7/8	28 7/8	-	-	-	-	128	137	-	-	-	-	-	-
CR(E) 10-4	3	3	115/208-230	182TC	18 3/8	18 3/8	8 5/8	6 7/8	32 7/8	32 7/8	-	-	-	-	165	172	-	-	-	-	-	-
			208-230/460	182TC	18 3/8	18 3/8	7 1/8	4 3/8	30 1/8	30 1/8	-	-	-	-	130	137	7	6 5/8	31 7/8	31 7/8	162	164
CR 10-5	5	3	208-230	182TC	19 1/2	19 1/2	10 5/8	7 1/2	34 7/8	34 7/8	-	-	-	-	183	189	-	-	-	-	-	-
			208-230/460	182TC	19 1/2	19 1/2	7 1/8	4 3/8	32 3/4	32 3/4	-	-	-	-	139	146	-	-	-	-	-	-
CR(E) 10-6	5	3	208-230	182TC	20 3/4	20 3/4	10 5/8	7 1/2	36 1/8	36 1/8	-	-	-	-	185	194	-	-	-	-	-	-
			208-230/460	182TC	20 3/4	20 3/4	7 1/8	4 3/8	34	34	-	-	-	-	141	148	8 3/4	7 1/2	36 1/4	36 1/4	199	201
CR 10-7	5	3	208-230	182TC	21 7/8	21 7/8	10 5/8	7 1/2	37 1/4	37 1/4	-	-	-	-	187	196	-	-	-	-	-	-
			208-230/460	182TC	21 7/8	21 7/8	7 1/8	4 3/8	37 7/8	35 1/8	-	-	-	-	144	150	-	-	-	-	-	-
CR(E) 10-8	7 1/2	3	208-230	213TC	23 3/8	23 3/8	10 1/4	7 1/2	38 3/4	38 3/4	-	-	-	-	211	218	-	-	-	-	-	-
			208-230/460	213TC	23 3/8	23 3/8	8 3/4	5 3/8	38 3/4	39	-	-	-	-	203	210	8 3/4	7 1/2	-	39	-	235
CR 10-9	7 1/2	3	208-230	213TC	24 1/2	24 1/2	10 1/4	7 1/2	39 7/8	39 7/8	-	-	-	-	213	220	-	-	-	-	-	-
			208-230/460	213TC	24 1/2	24 1/2	8 3/4	5 3/8	39 7/8	40 1/8	-	-	-	-	205	212	-	-	-	-	-	-
CR(E) 10-10	7 1/2	3	208-230	213TC	25 3/4	25 3/4	10 1/4	7 1/2	41 1/8	41 1/8	-	-	-	-	216	222	-	-	-	-	-	-
			208-230/460	213TC	25 3/4	25 3/4	8 3/4	5 3/8	41 1/8	41 3/8	-	-	-	-	230	214	8 3/4	7 1/2	-	41 3/8	-	239
CR(E) 10-12	10	3	230	213TC	-	28 1/8	10 1/4	10 3/8	-	44	-	-	-	-	251	-	-	-	-	-	-	-
			208-230/460	213TC	-	28 1/8	8 3/4	5 3/8	-	43 3/4	-	-	-	-	202	-	8 3/4	7 1/2	-	43 3/4	-	251
CR(E) 10-14	10	3	230	213TC	-	30 1/2	10 1/4	10 3/8	-	46 3/8	-	-	-	-	255	-	-	-	-	-	-	-
			208-230/460	213TC	-	30 1/2	8 3/4	5 3/8	-	46 1/8	-	-	-	-	207	-	8 3/4	7 1/2	-	51	-	255
CR 10-16	15	3	208-230/460	254TC	-	35 3/8	10 3/8	8 3/4	-	52	10 5/8	7 3/8	-	51 1/2	-	352	-	-	-	-	-	-
CR 10-17	15	3	208-230/460	254TC	-	37 3/4	16 5/8	10 3/8	-	54 3/8	10 5/8	7 3/8	-	53 7/8	-	359	-	-	-	-	-	-

Weights are based on pump with TEFC motor (see price list for individual weights)
All dimensions in inches unless otherwise noted.

Dimensional sketches

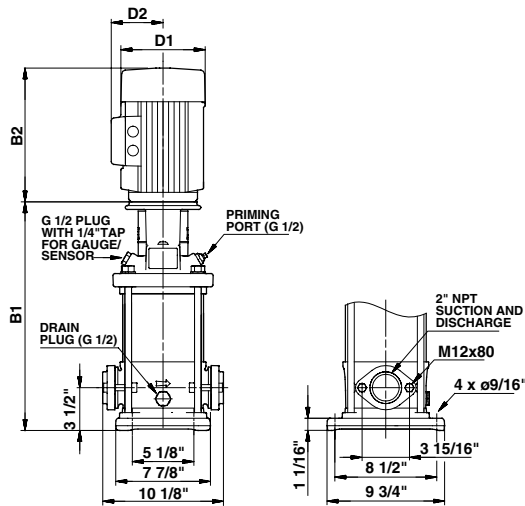

TM03 1458 2205

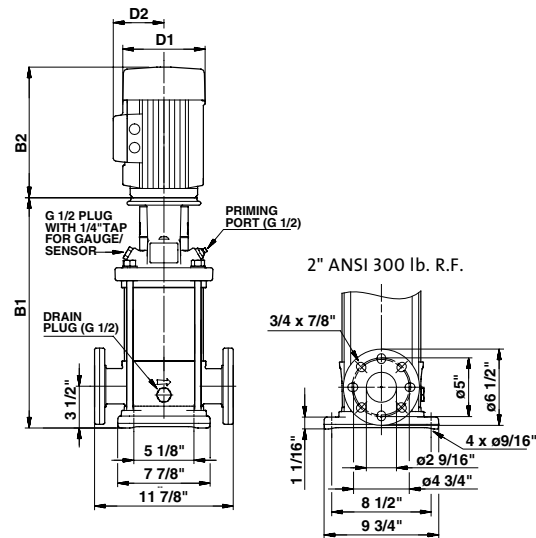

TM03 1459 2205

Dimensions and weights

Pump type	Hp	Ph	Voltage	NEMA Frame size	Oval B1	ANSI B1	TEFC				ODP				MLE		Oval Ship Wt. ¹ [lbs.]	ANSI Ship Wt. ¹ [lbs.]				
							D1	D2	Oval B1+B2	ANSI B1+B2	D1	D2	Oval B1+B2	ANSI B1+B2	D1	D2			Oval B1+B2	ANSI B1+B2		
CRI(E) 10-1	3/4	1	115/230	56C	15 1/4	15 1/4	6 1/4	5	25 1/4	25 1/4	-	-	-	-	97	103	5 1/2	5 1/2	23 1/8	23 1/8	79	83
		3	208-230/460	56C	15 1/4	15 1/4	5 5/8	4 5/8	24 1/8	24 1/8	-	-	-	-	79	85	-	-	-	-	-	-
CRI(E) 10-2	1 1/2	1	115/208-230	56C	15 1/4	15 1/4	7 1/4	5 3/4	27	27	-	-	-	-	112	119	5 1/2	5 1/2	24 3/8	24 3/8	95	102
		3	208-230/460	56C	15 1/4	15 1/4	5 5/8	4 5/8	24 1/8	24 1/8	-	-	-	-	94	100	7	6 5/8	26 3/4	26 3/4	110	116
CRI 10-3	3	1	115/208-230	182TC	17 1/8	17 1/8	8 5/8	6 7/8	31 5/8	31 5/8	-	-	-	-	163	169	-	-	-	-	-	-
		3	208-230/460	182TC	17 1/8	17 1/8	7 1/8	4 3/8	28 7/8	28 7/8	-	-	-	-	128	137	-	-	-	-	-	-
CRI(E) 10-4	3	1	115/208-230	182TC	18 3/8	18 3/8	8 5/8	6 7/8	32 7/8	32 7/8	-	-	-	-	165	172	-	-	-	-	-	-
		3	208-230/460	182TC	18 3/8	18 3/8	7 1/8	4 3/8	30 1/8	30 1/8	-	-	-	-	130	137	7	6 5/8	31 3/4	31 3/4	149	156
CRI 10-5	5	1	208-230	182TC	19 1/2	19 1/2	10 5/8	7 1/2	34 7/8	34 7/8	-	-	-	-	183	189	-	-	-	-	-	-
		3	208-230/460	182TC	19 1/2	19 1/2	7 1/8	4 3/8	32 3/4	32 3/4	-	-	-	-	139	146	-	-	-	-	-	-
CRI(E) 10-6	5	1	208-230	182TC	20 3/4	20 3/4	10 5/8	7 1/2	36 1/8	36 1/8	-	-	-	-	185	194	-	-	-	-	-	-
		3	208-230/460	182TC	20 3/4	20 3/4	7 1/8	4 3/8	34	34	-	-	-	-	141	148	8 3/4	7 1/2	36 1/4	36 1/4	186	192
CRI 10-7	5	1	208-230	182TC	21 7/8	21 7/8	10 5/8	7 1/2	37 1/4	37 1/4	-	-	-	-	187	196	-	-	-	-	-	-
		3	208-230/460	182TC	21 7/8	21 7/8	7 1/8	4 3/8	37 7/8	35 1/8	-	-	-	-	144	150	-	-	-	-	-	-
CRI(E) 10-8	7 1/2	1	208-230	213TC	23 3/8	23 3/8	10 1/4	7 1/2	38 3/4	38 3/4	-	-	-	-	211	218	-	-	-	-	-	-
		3	208-230/460	213TC	23 3/8	23 3/8	8 3/4	5 3/8	38 3/4	39	-	-	-	-	203	210	8 3/4	7 1/2	38 7/8	38 7/8	221	228
CRI 10-9	7 1/2	1	208-230	213TC	24 1/2	24 1/2	10 1/4	7 1/2	39 7/8	39 7/8	-	-	-	-	213	220	-	-	-	-	-	-
		3	208-230/460	213TC	24 1/2	24 1/2	8 3/4	5 3/8	39 7/8	40 1/8	-	-	-	-	205	212	-	-	-	-	-	-
CRI(E) 10-10	7 1/2	1	208-230	213TC	25 3/4	25 3/4	10 1/4	7 1/2	41 1/8	41 1/8	-	-	-	-	216	222	-	-	-	-	-	-
		3	208-230/460	213TC	25 3/4	25 3/4	8 3/4	5 3/8	41 1/8	41 3/8	-	-	-	-	230	214	8 3/4	7 1/2	41 1/4	41 1/4	248	232
CRI(E) 10-12	10	1	230	213TC	-	28 1/8	10 1/4	10 3/8	-	44	-	-	-	-	251	-	-	-	-	-	-	-
		3	208-230/460	213TC	-	28 1/8	8 3/4	5 3/8	-	43 3/4	-	-	-	-	202	-	8 3/4	7 1/2	-	43 5/8	-	244
CRI(E) 10-14	10	1	230	213TC	-	30 1/2	10 1/4	10 3/8	-	46 3/8	-	-	-	-	255	-	-	-	-	-	-	-
		3	208-230/460	213TC	-	30 1/2	8 3/4	5 3/8	-	46 1/8	-	-	-	-	207	-	8 3/4	7 1/2	-	46	-	248
CRI 10-16	15	3	208-230/460	254TC	-	35 3/8	10 3/8	8 3/4	-	52	10 5/8	7 3/8	-	51 1/2	352	-	-	-	-	-	-	-
CRI 10-17	15	3	208-230/460	254TC	-	37 3/4	16 5/8	10 3/8	-	54 3/8	10 5/8	7 3/8	-	53 7/8	359	-	-	-	-	-	-	-

Weights based on pump with TEFC motor (see price list for individual weights)

All dimensions in inches unless otherwise noted.

Dimensional sketches

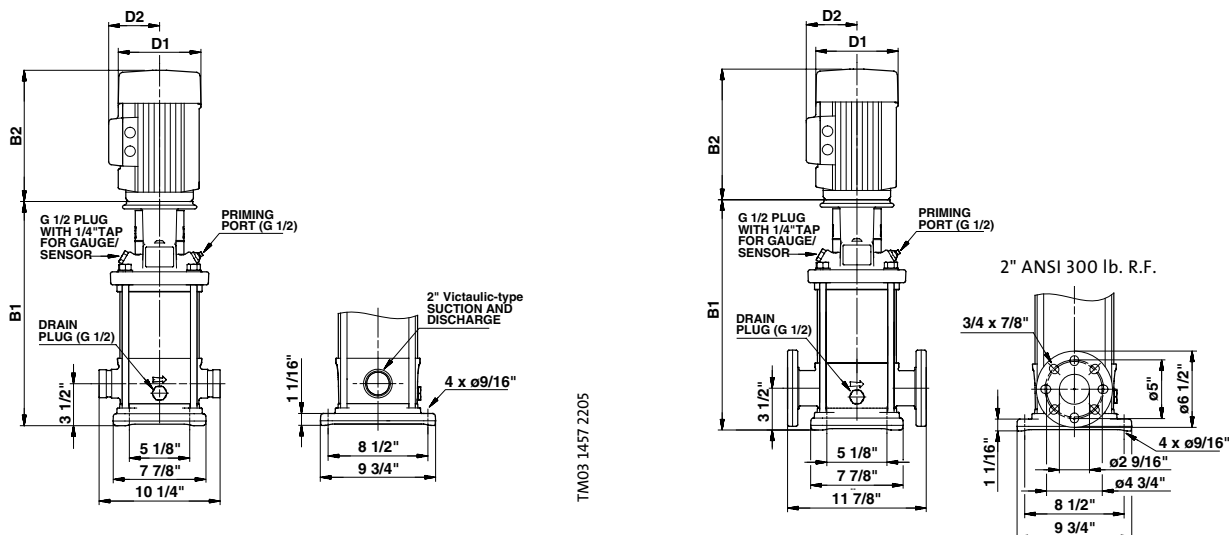

Dimensions and weights

Pump type	Hp	Ph	Voltage	NEMA Frame size	PJE B1	ANSI B1	TEFC				ODP				PJE		MLE				PJE		ANSI	
							D1	D2	PJE B1+B2	ANSI B1+B2	D1	D2	PJE B1+B2	ANSI B1+B2	Wt. ¹ [lbs.]	Ship Wt. ¹ [lbs.]	D1	D2	PJE B1+B2	ANSI B1+B2	Wt. ¹ [lbs.]	Ship Wt. ¹ [lbs.]	Wt. ¹ [lbs.]	Ship Wt. ¹ [lbs.]
CRN(E) 10-1	3/4	1	115/208-230	56C	15 1/4	15 1/4	6 1/4	5	25 1/4	25 1/4	-	-	-	-	92	103	5 1/2	5 1/2	23 1/8	23 1/8	74	83	-	-
		3	208-230/460	56C	15 1/4	15 1/4	5 5/8	4 5/8	24 1/8	24 1/8	-	-	-	-	74	85	-	-	-	-	-	-	-	-
CRN(E) 10-2	1 1/2	1	115/208-230	56C	15 1/4	15 1/4	7 1/4	5 3/4	27	27	-	-	-	-	110	119	5 1/2	5 1/2	24 3/8	24 3/8	67	76	-	-
		3	208-230/460	56C	15 1/4	15 1/4	5 5/8	4 5/8	24 1/8	24 1/8	-	-	-	-	89	100	7	6 5/8	26 3/4	26 3/4	105	116	-	-
CRN 10-3	3	1	115/208-230	182TC	17 1/8	17 1/8	8 5/8	6 7/8	31 5/8	31 5/8	-	-	-	-	161	169	-	-	-	-	-	-	-	-
		3	208-230/460	182TC	17 1/8	17 1/8	7 1/8	4 3/8	28 7/8	28 7/8	-	-	-	-	126	137	-	-	-	-	-	-	-	-
CRN(E) 10-4	3	1	115/208-230	182TC	18 3/8	18 3/8	8 5/8	6 7/8	32 7/8	32 7/8	-	-	-	-	161	172	-	-	-	-	-	-	-	-
		3	208-230/460	182TC	18 3/8	18 3/8	7 1/8	4 3/8	30 1/8	30 1/8	-	-	-	-	128	137	7	6 5/8	31 1/4	31 1/4	147	156	-	-
CRN 10-5	5	1	208-230	182TC	19 1/2	19 1/2	10 5/8	7 1/2	34 7/8	34 7/8	-	-	-	-	180	189	-	-	-	-	-	-	-	-
		3	208-230/460	182TC	19 1/2	19 1/2	7 1/8	4 3/8	32 3/4	32 3/4	-	-	-	-	137	146	-	-	-	-	-	-	-	-
CRN(E) 10-6	5	1	208-230	182TC	20 3/4	20 3/4	10 5/8	7 1/2	36 1/8	36 1/8	-	-	-	-	183	194	-	-	-	-	-	-	-	-
		3	208-230/460	182TC	20 3/4	20 3/4	7 1/8	4 3/8	34	34	-	-	-	-	139	148	8 3/4	7 1/2	35 3/8	35 3/8	184	192	-	-
CRN 10-7	5	1	208-230	182TC	21 7/8	21 7/8	10 5/8	7 1/2	37 1/4	37 1/4	-	-	-	-	185	196	-	-	-	-	-	-	-	-
		3	208-230/460	182TC	21 7/8	21 7/8	7 1/8	4 3/8	35 1/8	35 1/8	-	-	-	-	141	150	-	-	-	-	-	-	-	-
CRN(E) 10-8	7 1/2	1	208-230	213TC	23 3/8	23 3/8	10 1/4	7 1/2	38 3/4	38 3/4	-	-	-	-	207	218	-	-	-	-	-	-	-	-
		3	208-230/460	213TC	23 3/8	23 3/8	8 3/4	5 3/8	39	39	-	-	-	-	199	210	8 3/4	7 1/2	38 7/8	38 7/8	217	228	-	-
CRN 10-9	7 1/2	1	208-230	213TC	24 1/2	24 1/2	10 1/4	7 1/2	39 7/8	39 7/8	-	-	-	-	209	220	-	-	-	-	-	-	-	-
		3	208-230/460	213TC	24 1/2	24 1/2	8 3/4	5 3/8	40 1/8	40 1/8	-	-	-	-	201	212	-	-	-	-	-	-	-	-
CRN(E) 10-10	7 1/2	1	208-230	213TC	25 3/4	25 3/4	10 1/4	7 1/2	41 1/8	41 1/8	-	-	-	-	211	222	-	-	-	-	-	-	-	-
		3	208-230/460	213TC	25 3/4	25 3/4	8 3/4	5 3/8	41 3/8	41 3/8	-	-	-	-	203	214	8 3/4	7 1/2	41 1/4	41 1/4	221	232	-	-
CRN(E) 10-12	10	1	230	213TC	28 1/8	28 1/8	10 1/4	10 3/8	44	44	-	-	-	-	242	251	-	-	-	-	-	-	-	-
		3	208-230/460	213TC	28 1/8	28 1/8	8 3/4	5 3/8	43 3/4	43 3/4	-	-	-	-	191	202	8 3/4	7 1/2	43 5/8	43 5/8	233	244	-	-
CRN(E) 10-14	10	1	230	213TC	30 1/2	30 1/2	10 1/4	10 3/8	46 3/8	46 3/8	-	-	-	-	246	255	-	-	-	-	-	-	-	-
		3	208-230/460	213TC	30 1/2	30 1/2	8 3/4	5 3/8	46 1/8	46 1/8	-	-	-	-	196	207	8 3/4	7 1/2	46	46	237	248	-	-
CRN 10-16	15	3	208-230/460	254TC	35 3/8	35 3/8	10 3/8	8 3/4	52	52	10 5/8	7 3/8	51 1/2	51 1/2	343	352	-	-	-	-	-	-	-	-
CRN 10-17	15	3	208-230/460	254TC	37 3/4	37 3/4	16 5/8	10 3/8	53 7/8	54 3/8	10 5/8	7 3/8	8 3/4	54 3/8	348	359	-	-	-	-	-	-	-	-

Weights are based on pump with TEFC motor (see price list for individual weights)
All dimensions in inches unless otherwise noted.

Performance curves

CR(E), CRI(E), CRN(E) 15

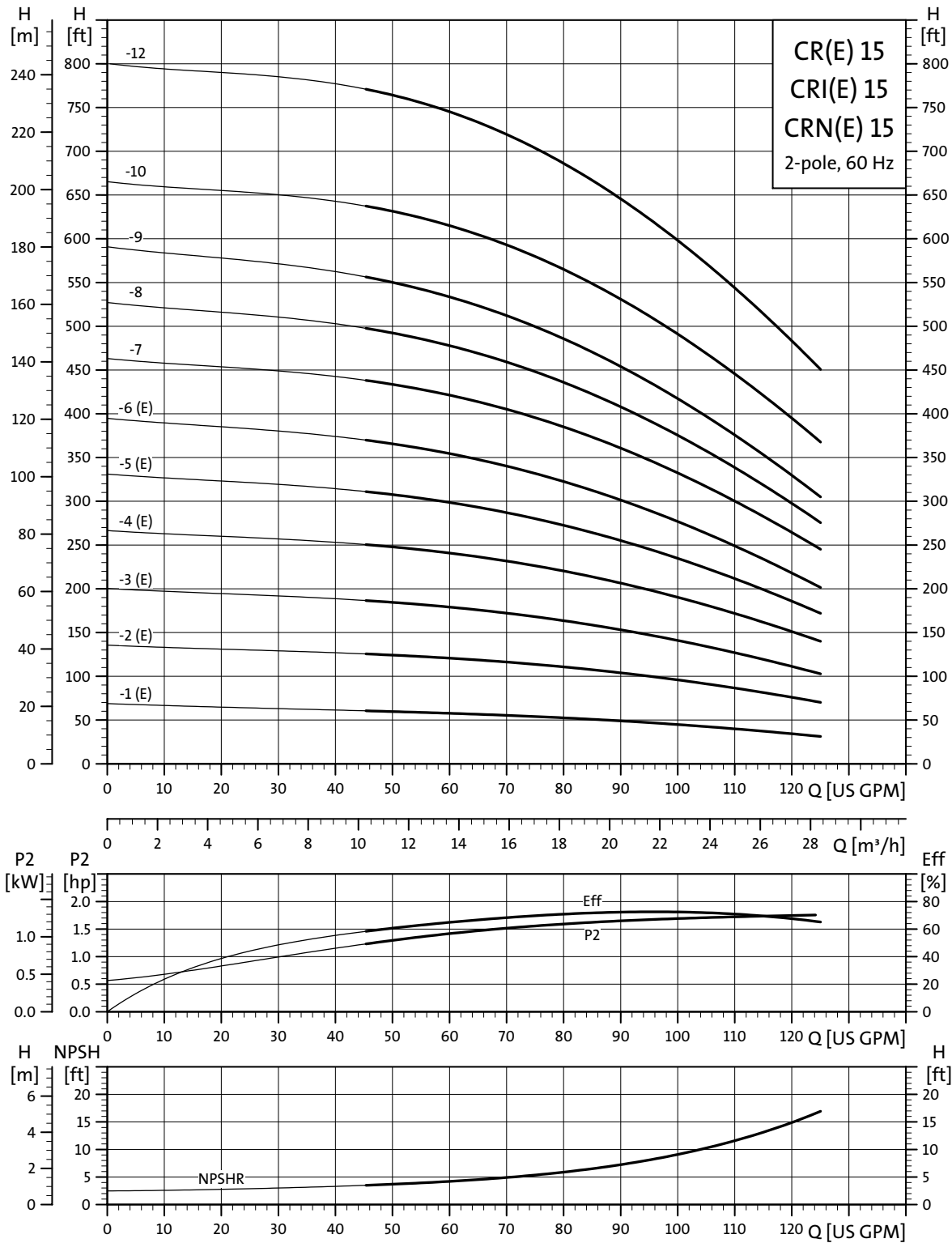

TM02 7222 2803

Dimensional sketches

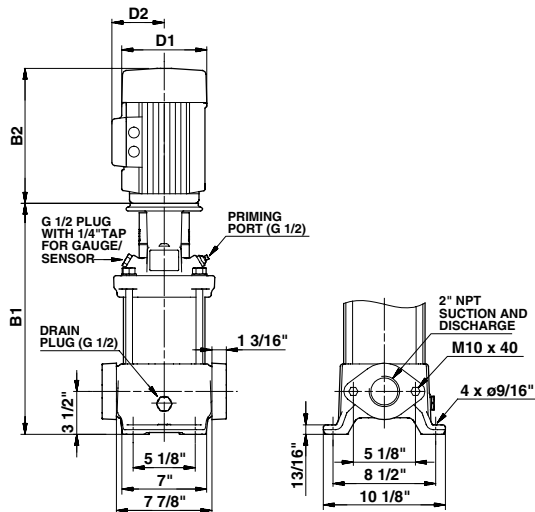

TM03 1460 2205

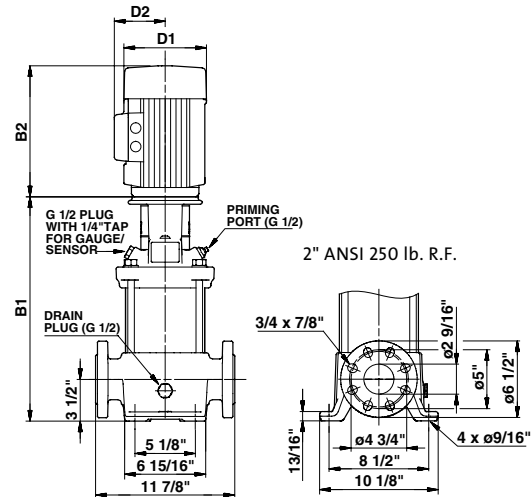

TM03 1461 2205

Dimensions and weights

Pump type	Hp	Ph	Voltage	NEMA Frame size	Oval B1	ANSI B1	TEFC				ODP				Oval ANSI Ship		MLE				Oval ANSI Ship	
							D1	D2	Oval B1+B2	ANSI B1+B2	D1	D2	Oval B1+B2	ANSI B1+B2	Wt. ¹ [lbs.]	Wt. ¹ [lbs.]	D1	D2	Oval B1+B2	ANSI B1+B2	Wt. ¹ [lbs.]	Wt. ¹ [lbs.]
CR(E) 15-1	2	1	115/208-230	56C	16 1/2	16 1/2	7 1/4	5 3/4	29 1/8	29 1/8	-	-	-	-	134	136	-	-	-	-	-	-
			208-230/460	56C	16 1/2	16 1/2	7 1/8	4 3/8	28	28	-	-	-	-	123	126	7	6 5/8	28	28	135	137
CR(E) 15-2	5	1	208-230	182TC	17 1/4	17 1/4	10 5/8	7 1/2	32 5/8	32 5/8	-	-	-	-	191	194	-	-	-	-	-	-
			208-230/460	182TC	17 1/4	17 1/4	7 1/8	4 3/8	30 1/2	30 1/2	-	-	-	-	146	148	8 3/4	7 1/2	32 5/8	32 5/8	190	192
CR(E) 15-3	5	1	208-230	182TC	19	19	10 5/8	7 1/2	34 3/8	34 3/8	-	-	-	-	194	196	-	-	-	-	-	-
			208-230/460	182TC	19	19	7 1/8	4 3/8	32 1/4	32 1/4	-	-	-	-	150	152	8 3/4	7 1/2	34 1/2	34 1/2	195	197
CR(E) 15-4	7 1/2	1	208-230	213TC	21 1/8	21 1/8	10 1/4	7 1/2	36 1/2	36 1/2	-	-	-	-	216	218	-	-	-	-	-	-
			208-230/460	213TC	21 1/8	21 1/8	8 3/4	5 3/8	36 3/4	36 3/4	-	-	-	-	205	208	8 3/4	7 1/2	36 5/8	36 5/8	224	226
CR(E) 15-5	10	1	230	213TC	22 7/8	22 7/8	10 1/4	10 3/8	38 3/4	38 3/4	-	-	-	-	244	246	-	-	-	-	-	-
			208-230/460	213TC	22 7/8	22 7/8	8 3/4	5 3/8	38 1/2	38 1/2	-	-	-	-	194	196	8 3/4	7 1/2	38 3/8	38 3/8	235	237
CR(E) 15-6	10	1	230	213TC	-	24 5/8	10 1/4	10 3/8	-	40 1/2	-	-	-	-	249	-	-	-	-	-	-	-
			208-230/460	213TC	-	24 5/8	8 3/4	5 3/8	-	40 1/4	-	-	-	-	200	-	8 3/4	7 1/2	-	40 1/8	-	242
CR 15-7	15	3	208-230/460	254TC	-	29	10 3/8	8 3/4	-	45 5/8	10 5/8	7 3/8	-	45 1/8	-	257	-	-	-	-	-	-
CR 15-8	15	3	208-230/460	254TC	-	30 3/4	10 3/8	8 3/4	-	47 3/8	10 5/8	7 3/8	-	46 7/8	-	262	-	-	-	-	-	-
CR 15-9	15	3	208-230/460	254TC	-	32 1/2	10 3/8	8 3/4	-	49 1/8	10 5/8	7 3/8	-	48 5/8	-	354	-	-	-	-	-	-
CR 15-10	20	3	230/460	254TC	-	34 1/4	10 3/8	8 3/4	-	50 5/8	11 1/2	9	-	52 1/4	-	407	-	-	-	-	-	-
CR 15-12	25	3	230/460	284TSC	-	37 1/4	13	9 1/2	-	57	11 1/2	9	-	58 1/4	-	498	-	-	-	-	-	-

Weights are based on pump with TEFC motor (see price list for individual weights)
All dimensions in inches unless otherwise noted.

Dimensional sketches

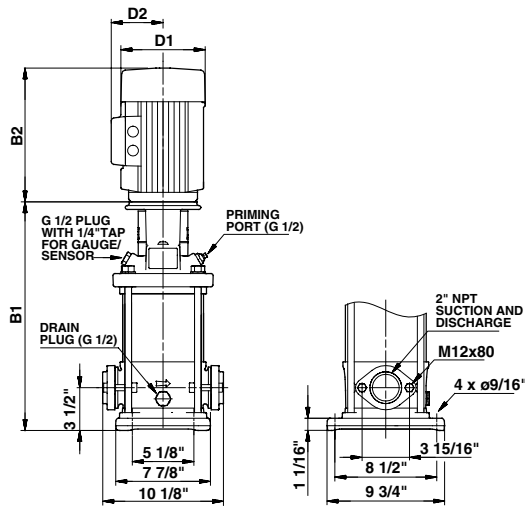

TM03 1458 2205

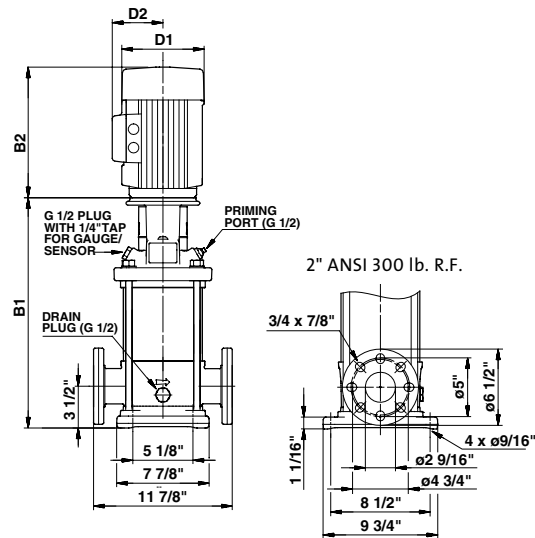

TM03 1459 2205

Dimensions and weights

Pump type	Hp	Ph	Voltage	NEMA Frame size	Oval B1	ANSI B1	TEFC				ODP				MLE					
							D1	D2	Oval B1+B2	ANSI B1+B2	D1	D2	Oval B1+B2	ANSI B1+B2	Oval Ship Wt. ¹ [lbs.]	ANSI Ship Wt. ¹ [lbs.]	D1	D2	Oval B1+B2	ANSI B1+B2
CRI(E) 15-1	2	1	115/208-230	56C	16 3/8	16 3/8	7 1/4	5 3/4	29	29	-	-	-	-	121	130	-	-	-	-
		3	208-230/460	56C	16 3/8	16 3/8	7 1/8	4 3/8	27 7/8	27 7/8	-	-	-	-	112	119	7	6 5/8	27 7/8	27 7/8
CRI(E) 15-2	5	1	208-230	182TC	17 1/8	17 1/8	10 5/8	7 1/2	32 1/2	32 1/2	-	-	-	-	178	185	-	-	-	-
		3	208-230/460	182TC	17 1/8	17 1/8	7 1/8	4 3/8	30 3/8	30 3/8	-	-	-	-	135	141	8 3/4	7 1/2	32 5/8	32 5/8
CRI(E) 15-3	5	1	208-230	182TC	18 7/8	18 7/8	10 5/8	7 1/2	34 1/4	34 1/4	-	-	-	-	183	189	-	-	-	-
		3	208-230/460	182TC	18 7/8	18 7/8	7 1/8	4 3/8	32 1/8	32 1/8	-	-	-	-	137	144	8 3/4	7 1/2	34 3/8	34 3/8
CRI(E) 15-4	7 1/2	1	208-230	213TC	21	21	10 1/4	7 1/2	36 3/8	36 3/8	-	-	-	-	202	209	-	-	-	-
		3	208-230/460	213TC	21	21	8 3/4	5 3/8	36 5/8	36 5/8	-	-	-	-	194	201	8 3/4	7 1/2	36 1/2	36 1/2
CRI(E) 15-5	10	1	230	213TC	22 3/4	22 3/4	10 1/4	10 3/8	38 5/8	38 5/8	-	-	-	-	231	238	-	-	-	-
		3	208-230/460	213TC	22 3/4	22 3/4	8 3/4	5 3/8	38 3/8	38 3/8	-	-	-	-	178	187	8 3/4	7 1/2	38 1/4	38 1/4
CRI(E) 15-6	10	1	230	213TC	24 1/2	24 1/2	10 1/4	10 3/8	40 3/8	40 3/8	-	-	-	-	235	242	-	-	-	-
		3	208-230/460	213TC	24 1/2	24 1/2	8 3/4	5 3/8	39 7/8	40 1/8	-	-	-	-	185	191	8 3/4	7 1/2	40	40
CRI 15-7	15	3	208-230/460	254TC	28 7/8	28 7/8	10 3/8	8 3/4	45 1/2	45 1/2	10 5/8	7 3/8	45	45	244	251	-	-	-	-
CRI 15-8	15	3	208-230/460	254TC	30 5/8	30 5/8	10 3/8	8 3/4	47 1/4	47 1/4	10 5/8	7 3/8	46 3/4	46 3/4	249	253	-	-	-	-
CRI 15-9	15	3	208-230/460	254TC	-	32 3/8	10 3/8	8 3/4	-	49	10 5/8	7 3/8	-	48 1/2	-	345	-	-	-	
CRI 15-10	20	3	230/460	254TC	-	34 1/8	10 3/8	8 3/4	-	50 1/2	11 1/2	9	-	52 1/8	-	400	-	-	-	
CRI 15-12	25	3	230/460	284TSC	-	37 1/8	13	9 1/2	-	56 7/8	11 1/2	9	-	58 1/8	-	387	-	-	-	

Weights based on pump with TEFC motor (see price list for individual weights)
All dimensions in inches unless otherwise noted.

Dimensional sketches

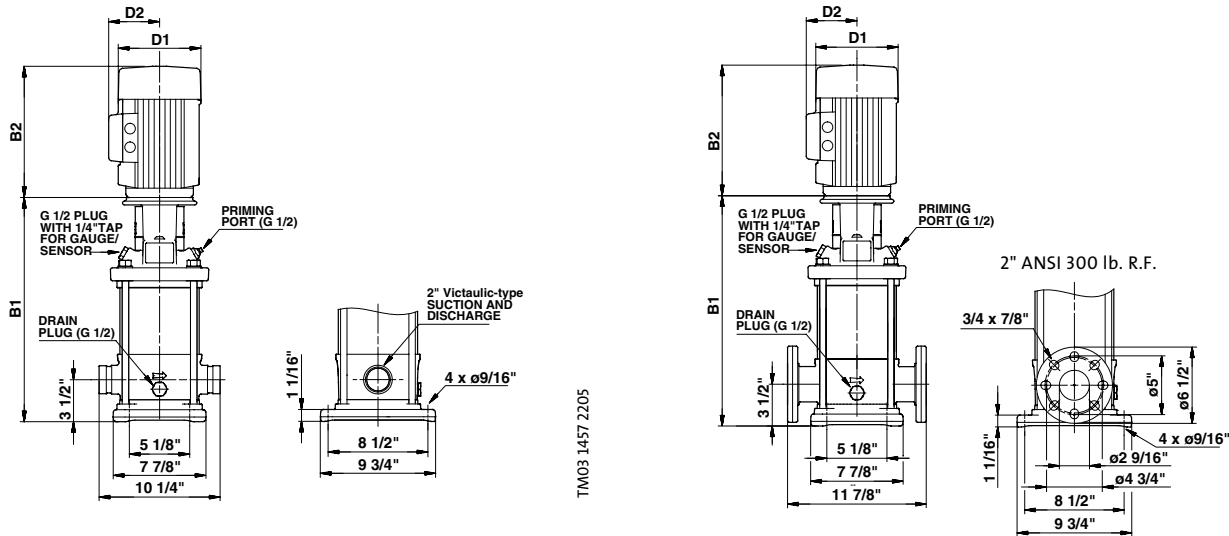

Dimensions and weights

Pump type	Hp	Ph	Voltage	NEMA Frame size	PJE B1	ANSI B1	TEFC				ODP				PJE		MLE				PJE		ANSI		
							D1	D2	PJE B1+B2	ANSI B1+B2	D1	D2	PJE B1+B2	ANSI B1+B2	Ship Wt. ¹ [lbs.]	Ship Wt. ¹ [lbs.]	D1	D2	PJE B1+B2	ANSI B1+B2	Ship Wt. ¹ [lbs.]	Ship Wt. ¹ [lbs.]			
CRN(E) 15-1	2	1	115/208-230	56C	16 3/8	16 3/8	7 1/4	5 3/4	29	29	-	-	-	-	119	130	-	-	-	-	-	-	-	-	-
		3	208-230/460	56C	16 3/8	16 3/8	7 1/8	4 3/8	27 7/8	27 7/8	-	-	-	-	108	119	7	6 5/8	27 7/8	27 7/8	120	131	-	-	
CRN(E) 15-2	5	1	208-230	182TC	17 1/8	17 1/8	10 5/8	7 1/2	32 1/2	32 1/2	-	-	-	-	176	185	-	-	-	-	-	-	-	-	-
		3	208-230/460	182TC	17 1/8	17 1/8	7 1/8	4 3/8	30 3/8	30 3/8	-	-	-	-	130	141	8 3/4	7 1/2	32 5/8	32 5/8	175	186	-	-	
CRN(E) 15-3	5	1	208-230	182TC	18 7/8	18 7/8	10 5/8	7 1/2	34 1/4	34 1/4	-	-	-	-	178	189	-	-	-	-	-	-	-	-	-
		3	208-230/460	182TC	18 7/8	18 7/8	7 1/8	4 3/8	32 1/8	32 1/8	-	-	-	-	135	144	8 3/4	7 1/2	34 3/8	34 3/8	179	188	-	-	
CRN(E) 15-4	7 1/2	1	208-230	213TC	21	21	10 1/4	7 1/2	36 3/8	36 3/8	-	-	-	-	200	209	-	-	-	-	-	-	-	-	-
		3	208-230/460	213TC	21	21	8 3/4	5 3/8	36 5/8	36 5/8	-	-	-	-	190	201	8 3/4	7 1/2	36 1/2	36 1/2	208	219	-	-	
CRN(E) 15-5	10	1	230	213TC	22 3/4	22 3/4	10 1/4	10 3/8	38 5/8	38 5/8	-	-	-	-	229	238	-	-	-	-	-	-	-	-	-
		3	208-230/460	213TC	22 3/4	22 3/4	8 3/4	5 3/8	38 3/8	38 3/8	-	-	-	-	176	187	8 3/4	7 1/2	38 1/4	38 1/4	218	229	-	-	
CRN(E) 15-6	10	1	230	213TC	24 1/2	24 1/2	10 1/4	10 3/8	40 3/8	40 3/8	-	-	-	-	231	242	-	-	-	-	-	-	-	-	-
		3	208-230/460	213TC	24 1/2	24 1/2	8 3/4	5 3/8	40 1/8	40 1/8	-	-	-	-	183	191	8 3/4	7 1/2	40	40	224	233	-	-	
CRN 15-7	15	3	208-230/460	254TC	28 7/8	28 7/8	10 3/8	8 3/4	45 1/2	45 1/2	10 5/8	7 3/8	45	45	240	251	-	-	-	-	-	-	-	-	-
CRN 15-8	15	3	208-230/460	254TC	30 5/8	30 5/8	10 3/8	8 3/4	47 1/4	47 1/4	10 5/8	7 3/8	46 3/4	46 3/4	244	253	-	-	-	-	-	-	-	-	-
CRN 15-9	15	3	208-230/460	254TC	32 3/8	32 3/8	10 3/8	8 3/4	49	49	10 5/8	7 3/8	48 1/2	48 1/2	337	345	-	-	-	-	-	-	-	-	-
CRN 15-10	20	3	230/460	254TC	34 1/8	34 1/8	10 3/8	8 3/4	50 1/2	50 1/2	11 1/2	9	52 1/8	52 1/8	389	400	-	-	-	-	-	-	-	-	-
CRN 15-12	25	3	230/460	284TSC	37 1/8	37 1/8	13	9 1/2	56 7/8	56 7/8	11 1/2	9	58 1/8	58 1/8	376	387	-	-	-	-	-	-	-	-	-

Weights based on pump with TEFC-motor (see price list for individual weights)
All dimensions in inches unless otherwise noted.

Performance curves

CR(E) 20
CRI(E) 20
CRN(E) 20
2-pole, 60 Hz

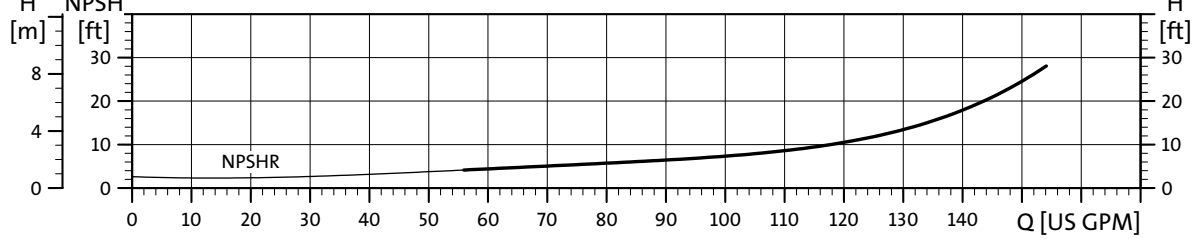
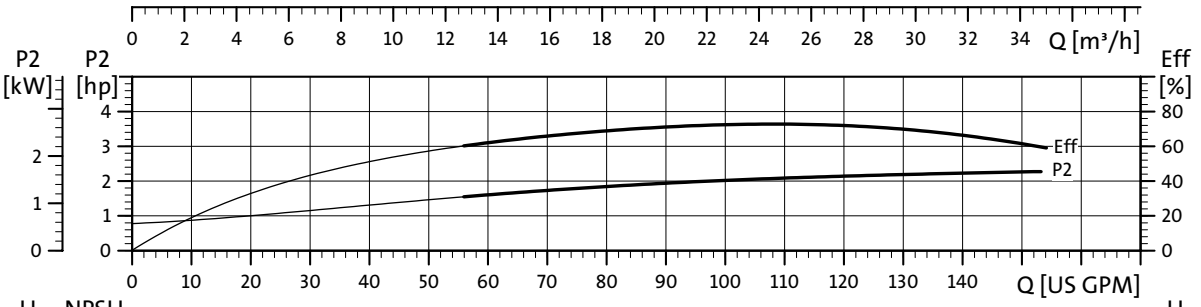
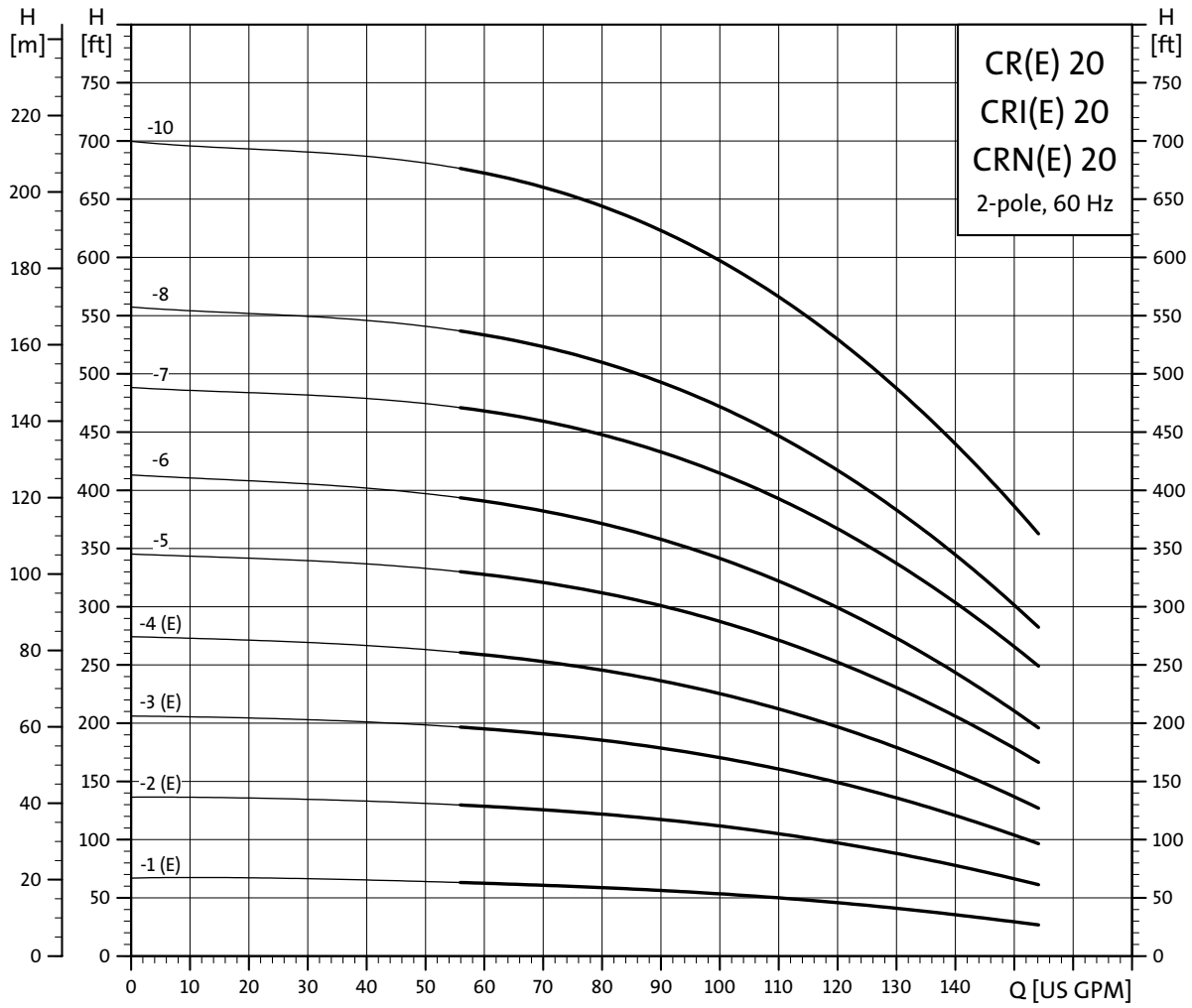

TM02 7223 2803

Dimensional sketches

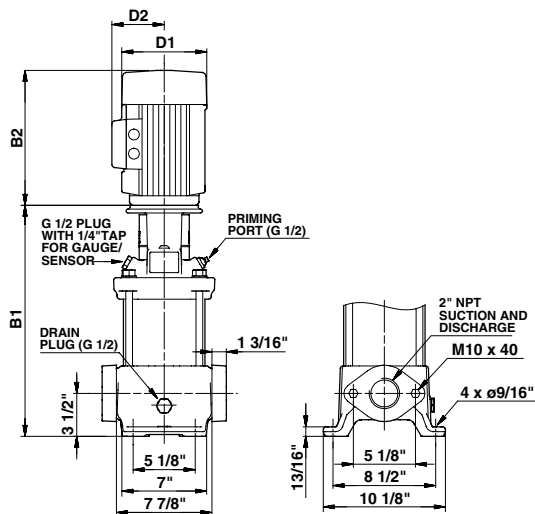

TM03 1460 2205

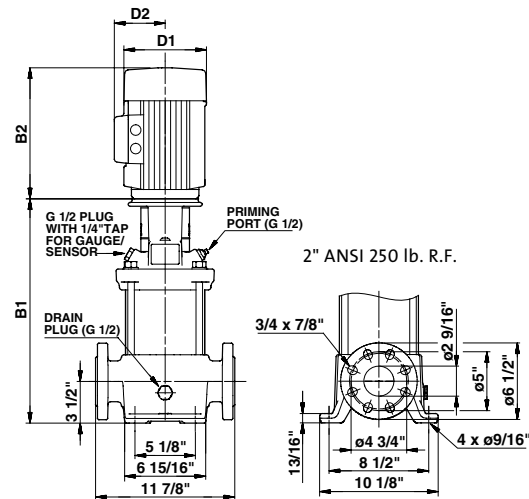

TM03 1461 2205

Dimensions and weights

Pump type	Hp	Ph	Voltage	NEMA Frame size	Oval B1	ANSI B1	TEFC				ODP				Oval ANSI Ship		MLE				Oval ANSI Ship	
							D1	D2	Oval B1+B2	ANSI B1+B2	D1	D2	Oval B1+B2	ANSI B1+B2	Wt. ¹ [lbs.]	Wt. ¹ [lbs.]	D1	D2	Oval B1+B2	ANSI B1+B2	Wt. ¹ [lbs.]	Wt. ¹ [lbs.]
CR(E) 20-1	3	1	115/208-230	56C	17 1/8	17 1/8	8 5/8	6 7/8	31 5/8	31 5/8	-	-	-	-	163	169	-	-	-	-	-	-
			208-230/460	56C	17 1/8	17 1/8	7 1/8	4 3/8	28 5/8	28 5/8	-	-	-	-	128	134	7	6 5/8	30 5/8	30 5/8	158	160
CR(E) 20-2	5	1	208-230	182TC	17 1/8	17 1/8	10 5/8	7 1/2	32 1/2	32 1/2	-	-	-	-	178	185	-	-	-	-	-	-
			208-230/460	182TC	17 1/8	17 1/8	7 1/8	4 3/8	30 3/8	30 3/8	-	-	-	-	135	141	8 3/4	7 1/2	32 3/4	32 3/4	190	192
CR(E) 20-3	7 1/2	1	208-230	213TC	19 1/4	19 1/4	10 1/4	7 1/2	34 5/8	34 5/8	-	-	-	-	200	207	-	-	-	-	-	-
			208-230/460	213TC	19 1/4	19 1/4	8 3/4	5 3/8	34 7/8	34 7/8	-	-	-	-	192	199	8 3/4	7 1/2	34 7/8	34 7/8	221	224
CR(E) 20-4	10	1	230	213TC	21	21	10 1/4	10 3/8	36 7/8	36 7/8	-	-	-	-	227	233	-	-	-	-	-	-
			208-230/460	213TC	21	21	8 3/4	5 3/8	36 5/8	36 5/8	-	-	-	-	176	183	8 3/4	7 1/2	36 5/8	36 5/8	229	231
CR 20-5	15	3	208-230/460	254TC	25 3/8	25 3/8	10 3/8	8 3/4	42	42	10 5/8	7 3/8	41 1/2	41 1/2	238	244	-	-	-	-	-	-
CR 20-6	15	3	208-230/460	254TC	27 1/8	27 1/8	10 3/8	8 3/4	43 3/4	43 3/4	10 5/8	7 3/8	43 1/4	43 1/4	240	246	-	-	-	-	-	-
CR 20-7	20	3	230/460	254TC	28 7/8	28 7/8	10 3/8	8 3/4	45 1/4	45 1/4	11 1/2	9	46 7/8	46 7/8	381	387	-	-	-	-	-	-
CR 20-8	20	3	230/460	254TC	-	30 5/8	10 3/8	8 3/4	-	47	11 1/2	9	-	48 5/8	-	392	-	-	-	-	-	
CR 20-10	25	3	230/460	284TSC	-	33 1/2	13	9 1/2	-	53 1/4	11 1/2	9	-	54 1/2	-	381	-	-	-	-	-	

Weights based on pump with TEFC motor (see price list for individual weights)
All dimensions in inches unless otherwise noted.

Dimensional sketches

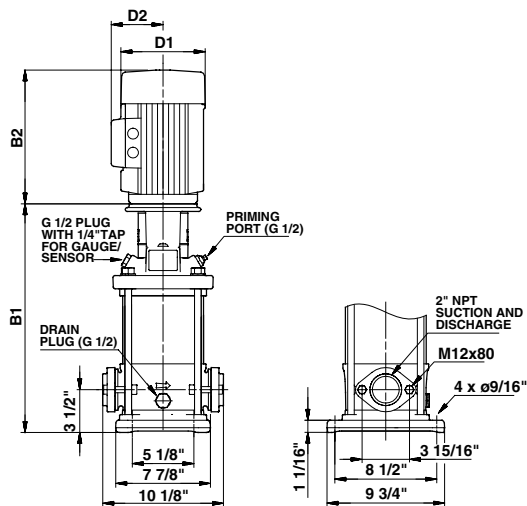

TM03 1458 2205

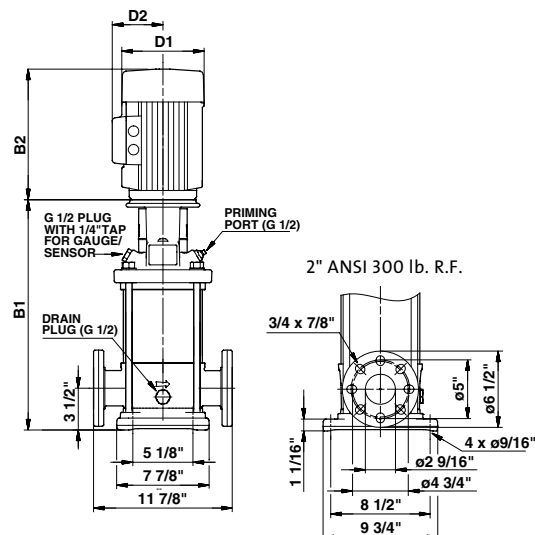

TM03 1459 2205

Dimensions and weights

Pump type	Hp	Ph	Voltage	NEMA Frame size	Oval B1	ANSI B1	TEFC				ODP				Oval Ship Wt. ¹ [lbs.]	ANSI Ship Wt. ¹ [lbs.]	MLE				Oval Ship Wt. ¹ [lbs.]	ANSI Ship Wt. ¹ [lbs.]
							D1	D2	Oval B1+B2	ANSI B1+B2	D1	D2	Oval B1+B2	ANSI B1+B2			D1	D2	Oval B1+B2	ANSI B1+B2		
CRI(E) 20-1	3	1	115/208-230	56C	17 1/8	17 1/8	8 5/8	6 7/8	31 5/8	31 5/8	-	-	-	-	163	169	-	-	-	-	-	-
		3	208-230/460	56C	17 1/8	17 1/8	7 1/8	4 3/8	28 5/8	28 5/8	-	-	-	-	128	134	7	6 5/8	30 1/2	30 1/2	158	160
CRI(E) 20-2	5	1	208-230	182TC	17 1/8	17 1/8	10 5/8	7 1/2	32 1/2	32 1/2	-	-	-	-	178	185	-	-	-	-	-	-
		3	208-230/460	182TC	17 1/8	17 1/8	7 1/8	4 3/8	30 3/8	30 3/8	-	-	-	-	135	141	8 3/4	7 1/2	32 5/8	32 5/8	190	192
CRI(E) 20-3	7 1/2	1	208-230	213TC	19 1/4	19 1/4	10 1/4	7 1/2	34 5/8	34 5/8	-	-	-	-	200	207	-	-	-	-	-	-
		3	208-230/460	213TC	19 1/4	19 1/4	8 3/4	5 3/8	34 7/8	34 7/8	-	-	-	-	192	199	8 3/4	7 1/2	34 3/4	34 3/4	221	224
CRI(E) 20-4	10	1	230	213TC	21	21	10 1/4	10 3/8	36 7/8	36 7/8	-	-	-	-	227	233	-	-	-	-	-	-
		3	208-230/460	213TC	21	21	8 3/4	5 3/8	36 5/8	36 5/8	-	-	-	-	176	183	8 3/4	7 1/2	36 1/2	36 1/2	229	231
CRI 20-5	15	3	208-230/460	254TC	25 3/8	25 3/8	10 3/8	8 3/4	42	42	10 5/8	7 3/8	41 1/2	41 1/2	238	244	-	-	-	-	-	-
CRI 20-6	15	3	208-230/460	254TC	27 1/8	27 1/8	10 3/8	8 3/4	43 3/4	43 3/4	10 5/8	7 3/8	43 1/4	43 1/4	240	246	-	-	-	-	-	-
CRI 20-7	20	3	230/460	254TC	28 7/8	28 7/8	10 3/8	8 3/4	45 1/4	45 1/4	11 1/2	9	46 7/8	46 7/8	381	387	-	-	-	-	-	-
CRI 20-8	20	3	230/460	254TC	-	30 5/8	10 3/8	8 3/4	-	47	11 1/2	9	-	48 5/8	-	392	-	-	-	-	-	-
CRI 20-10	25	3	230/460	284TSC	-	33 1/2	13	9 1/2	-	53 1/4	11 1/2	9	-	54 1/2	-	381	-	-	-	-	-	-

Weights based on pump with TEFC motor (see price list for individual weights)
All dimensions in inches unless otherwise noted.

Dimensional sketches

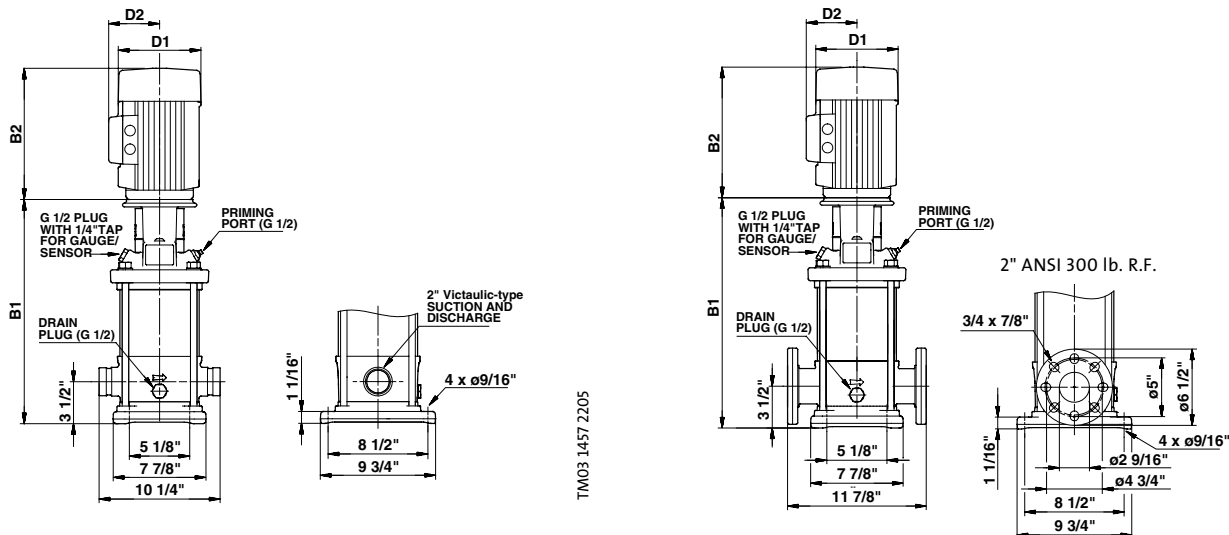

Dimensions and weights

Pump type	Hp	Ph	Voltage	NEMA Frame size	PJE B1	ANSI B1	TEFC				ODP				PJE Ship		MLE				PJE Ship	
							D1	D2	PJE B1+B2	ANSI B1+B2	D1	D2	PJE B1+B2	ANSI B1+B2	Wt. ¹ [lbs.]	Wt. ¹ [lbs.]	D1	D2	PJE B1+B2	ANSI B1+B2	Wt. ¹ [lbs.]	Wt. ¹ [lbs.]
CRN(E) 20-1	3	1	115/208-230	56C	17 1/8	17 1/8	8 5/8	6 7/8	31 5/8	31 5/8	-	-	-	-	158	169	-	-	-	-	-	-
		3	208-230/460	56C	17 1/8	17 1/8	7 1/8	4 3/8	28 5/8	28 5/8	-	-	-	-	123	134	7	6 5/8	30 1/2	30 1/2	142	153
CRN(E) 20-2	5	1	208-230	182TC	17 1/8	17 1/8	10 5/8	7 1/2	32 1/2	32 1/2	-	-	-	-	176	185	-	-	-	-	-	-
		3	208-230/460	182TC	17 1/8	17 1/8	7 1/8	4 3/8	30 3/8	30 3/8	-	-	-	-	130	141	8 3/4	7 1/2	32 5/8	32 5/8	175	186
CRN(E) 20-3	7 1/2	1	208-230	213TC	19 1/4	19 1/4	10 1/4	7 1/2	34 5/8	34 5/8	-	-	-	-	196	207	-	-	-	-	-	-
		3	208-230/460	213TC	19 1/4	19 1/4	8 3/4	5 3/8	34 7/8	34 7/8	-	-	-	-	188	199	8 3/4	7 1/2	34 3/4	34 3/4	206	217
CRN(E) 20-4	10	1	230	213TC	21	21	10 1/4	10 3/8	36 7/8	36 7/8	-	-	-	-	222	233	-	-	-	-	-	-
		3	208-230/460	213TC	21	21	8 3/4	5 3/8	36 5/8	36 5/8	-	-	-	-	172	183	8 3/4	7 1/2	36 1/2	36 1/2	213	224
CRN 20-5	15	3	208-230/460	254TC	25 3/8	25 3/8	10 3/8	8 3/4	42	42	10 5/8	7 3/8	41 1/2	41 1/2	233	244	-	-	-	-	-	-
CRN 20-6	15	3	208-230/460	254TC	27 1/8	27 1/8	10 3/8	8 3/4	43 3/4	43 3/4	10 5/8	7 3/8	43 1/4	43 1/4	235	246	-	-	-	-	-	-
CRN 20-7	20	3	230/460	254TC	28 7/8	28 7/8	10 3/8	8 3/4	45 1/4	45 1/4	11 1/2	9	46 7/8	46 7/8	376	387	-	-	-	-	-	-
CRN 20-8	20	3	230/460	254TC	30 5/8	30 5/8	10 3/8	8 3/4	47	47	11 1/2	9	48 5/8	48 5/8	381	392	-	-	-	-	-	-
CRN 20-10	25	3	230/460	284TSC	33 1/2	33 1/2	13	9 1/2	53 1/4	53 1/4	11 1/2	9	54 1/2	54 1/2	370	381	-	-	-	-	-	-

Weights based on pump with TEFC motor (see price list for individual weights)

All dimensions in inches unless otherwise noted.

Performance curves

CR(E), CRN(E) 32

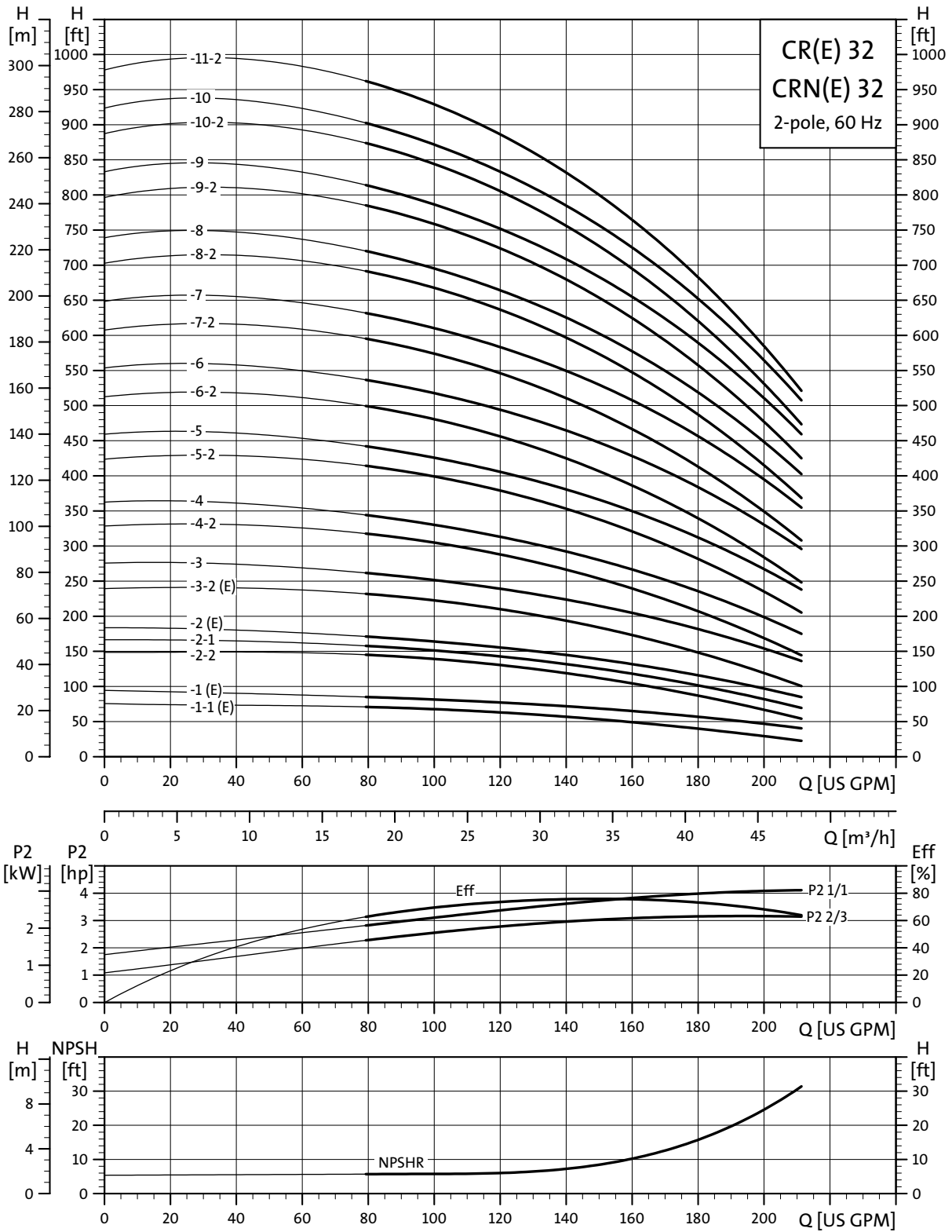

TM02 0039 1303

Dimensional sketches

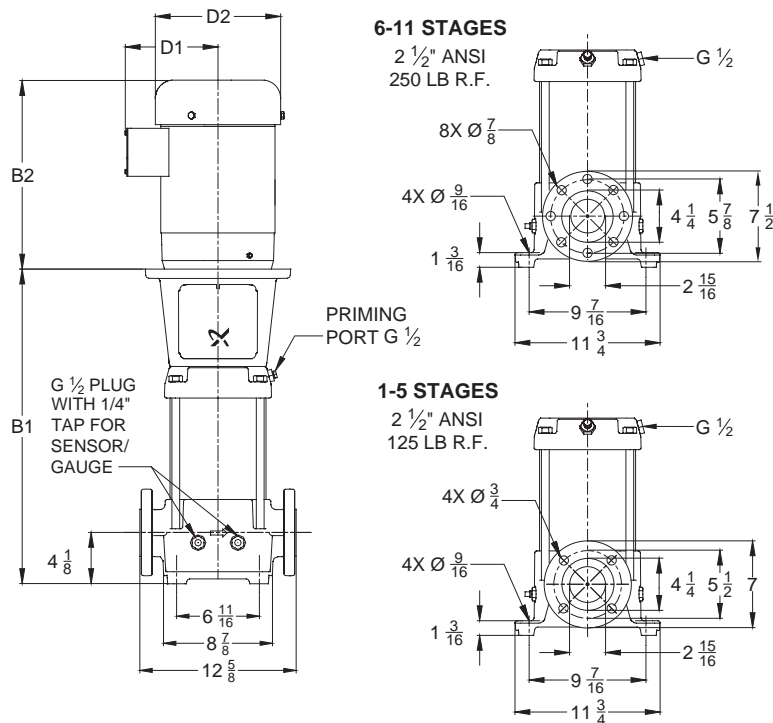

TMO27699 3804

Dimensions and weights

Pump type	Hp	Ph	Voltage	NEMA Frame size	ANSI B1	TEFC			ODP			ANSI Ship Wt. ¹ [lbs.]	MLE			ANSI Ship Wt. ¹ [lbs.]
						D1	D2	ANSI B1+B2	D1	D2	ANSI B1+B2		D1	D2	ANSI B1+B2	
CR(E) 32-1-1	3	1	115/208-230	182TC	20	8 5/8	6 7/8	34 1/2	-	-	-	232	-	-	-	-
		3	208-230/460	182TC	20	7 1/8	4 3/8	31 3/4	-	-	-	207	7	6 5/8	32 2/3	213
CR(E) 32-1	5	1	208-230	182TC	20	10 5/8	7 1/2	35 3/8	-	-	-	256	-	-	-	-
		3	208-230/460	182TC	20	7 1/8	4 3/8	33 1/4	-	-	-	213	8 3/4	7 1/2	34 5/8	236
CR 32-2-2	7 1/2	1	208-230	213TC	22 3/4	10 1/4	7 1/2	38 1/8	-	-	-	277	-	-	-	-
		3	208-230/460	213TC	22 3/4	8 3/4	5 3/8	38 3/8	-	-	-	255	-	-	-	-
CR 32-2-1	7 1/2	1	208-230	213TC	22 3/4	10 1/4	7 1/2	38 1/8	-	-	-	277	-	-	-	-
		3	208-230/460	213TC	22 3/4	8 3/4	5 3/8	38 3/8	-	-	-	255	-	-	-	-
CR(E) 32-2	7 1/2	1	208-230	213TC	22 3/4	10 1/4	7 1/2	38 1/8	-	-	-	277	-	-	-	-
		3	208-230/460	213TC	22 3/4	8 3/4	5 3/8	38 3/8	-	-	-	255	8 3/4	7 1/2	38 1/8	285
CR(E) 32-3-2	10	1	230	213TC	25 1/2	10 1/4	10 3/8	41 3/8	-	-	-	334	-	-	-	-
		3	208-230/460	213TC	25 1/2	8 3/4	5 3/8	41 1/8	-	-	-	290	8 3/4	7 1/2	40 9/10	314
CR 32-3	15	3	208-230/460	254TC	29 3/4	10 3/8	8 3/4	46 3/8	10 5/8	7 3/8	45 7/8	326	-	-	-	-
CR 32-4-2	15	3	208-230/460	254TC	32 1/2	10 3/8	8 3/4	49 1/8	10 5/8	7 3/8	48 5/8	441	-	-	-	-
CR 32-4	15	3	208-230/460	254TC	32 1/2	10 3/8	8 3/4	49 1/8	10 5/8	7 3/8	48 5/8	441	-	-	-	-
CR 32-5-2	20	3	230/460	254TC	35 1/4	10 3/8	8 3/4	51 5/8	11 1/2	9	53 1/4	507	-	-	-	-
CR 32-5	20	3	230/460	254TC	35 1/4	10 3/8	8 3/4	51 5/8	11 1/2	9	53 1/4	507	-	-	-	-
CR 32-6-2	25	3	230/460	284TSC	38	13	9 1/2	57 3/4	11 1/2	9	59	546	-	-	-	-
CR 32-6	25	3	230/460	284TSC	38	13	9 1/2	57 3/4	11 1/2	9	59	546	-	-	-	-
CR 32-7-2	25	3	230/460	284TSC	40 3/4	13	9 1/2	60 1/2	11 1/2	9	61 3/4	555	-	-	-	-
CR 32-7	30	3	230/460	284TSC	40 3/4	15 3/8	13 1/8	63 3/4	11 1/2	9	62 3/8	601	-	-	-	-
CR 32-8-2	30	3	230/460	284TSC	43 5/8	15 3/8	13 1/8	66 5/8	11 1/2	9	65 1/4	610	-	-	-	-
CR 32-8	30	3	230/460	284TSC	43 5/8	15 3/8	13 1/8	66 5/8	11 1/2	9	65 1/4	610	-	-	-	-
CR 32-9-2	40	3	230/460	286TSC	46 3/8	15 3/8	13 1/8	69 3/8	13 1/4	12 1/4	69 3/8	696	-	-	-	-
CR 32-9	40	3	230/460	286TSC	46 3/8	15 3/8	13 1/8	69 3/8	13 1/4	12 1/4	69 3/8	696	-	-	-	-
CR 32-10-2	40	3	230/460	286TSC	49 1/8	15 3/8	13 1/8	72 1/8	13 1/4	12 1/4	72 1/8	705	-	-	-	-
CR 32-10	40	3	230/460	286TSC	49 1/8	15 3/8	13 1/8	72 1/8	13 1/4	12 1/4	72 1/8	705	-	-	-	-
CR 32-11-2	40	3	230/460	286TSC	51 7/8	15 3/8	13 1/8	74 7/8	13 1/4	12 1/4	74 7/8	731	-	-	-	-

Weights based on pump with TEFC motor (see price list for individual weights)
All dimensions in inches unless otherwise noted.

Dimensional sketches

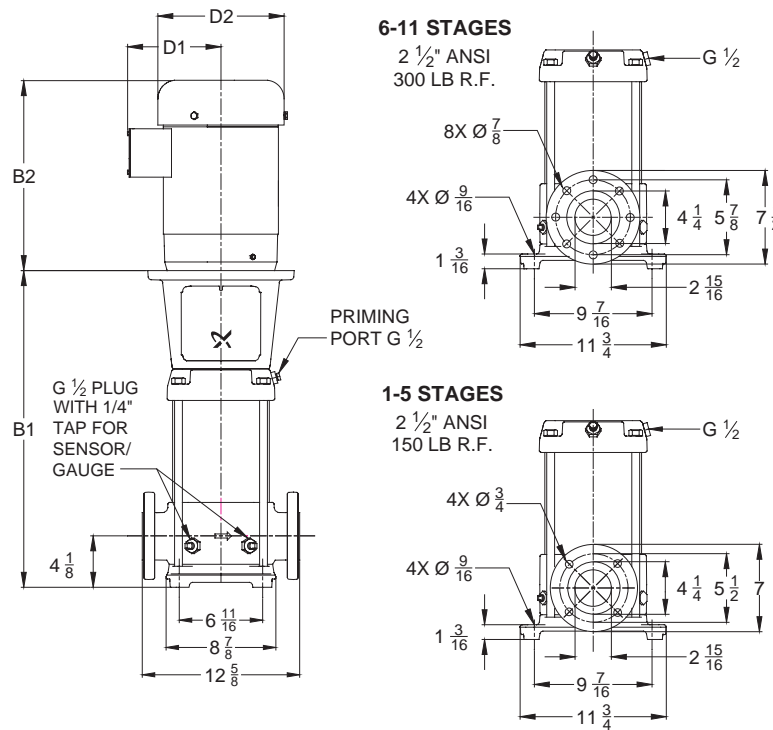

TM02 7703 3804

Dimensions and weights

Pump type	Hp	Ph	Voltage	NEMA Frame size	ANSI B1	TEFC			ODP			ANSI Ship Wt. ¹ [lbs.]	MLE			ANSI Ship Wt. ¹ [lbs.]
						D1	D2	ANSI B1+B2	D1	D2	ANSI B1+B2		D1	D2	ANSI B1+B2	
CRN(E) 32-1-1	3	1	115/208-230	182TC	20	8 5/8	6 7/8	34 1/2	-	-	-	232	-	-	-	-
			208-230/460	182TC	20	7 1/8	4 3/8	31 3/4	-	-	-	207	7	6 5/8	32 2/3	213
CRN(E) 32-1	5	1	208-230	182TC	20	10 5/8	7 1/2	35 3/8	-	-	-	256	-	-	-	-
			208-230/460	182TC	20	7 1/8	4 3/8	33 1/4	-	-	-	213	8 3/4	7 1/2	34 5/8	236
CRN 32-2-2	7 1/2	1	208-230	213TC	22 3/4	10 1/4	7 1/2	38 1/8	-	-	-	277	-	-	-	-
			208-230/460	213TC	22 3/4	8 3/4	5 3/8	38 3/8	-	-	-	255	-	-	-	-
CRN 32-2-1	7 1/2	3	208-230	213TC	22 3/4	10 1/4	7 1/2	38 1/8	-	-	-	277	-	-	-	-
			208-230/460	213TC	22 3/4	8 3/4	5 3/8	38 3/8	-	-	-	255	-	-	-	-
CRN(E) 32-2	7 1/2	1	208-230	213TC	22 3/4	10 1/4	7 1/2	38 1/8	-	-	-	277	-	-	-	-
			208-230/460	213TC	22 3/4	8 3/4	5 3/8	38 3/8	-	-	-	255	8 3/4	7 1/2	38 1/8	285
CRN(E) 32-3-2	10	1	230	213TC	25 1/2	10 1/4	10 3/8	41 3/8	-	-	-	334	-	-	-	-
			208-230/460	213TC	25 1/2	8 3/4	5 3/8	41 1/8	-	-	-	290	8 3/4	7 1/2	40 9/10	314
CRN 32-3	15	3	208-230/460	254TC	29 3/4	10 3/8	8 3/4	46 3/8	10 5/8	7 3/8	45 7/8	326	-	-	-	-
CRN 32-4-2	15	3	208-230/460	254TC	32 1/2	10 3/8	8 3/4	49 1/8	10 5/8	7 3/8	48 5/8	441	-	-	-	-
CRN 32-4	15	3	208-230/460	254TC	32 1/2	10 3/8	8 3/4	49 1/8	10 5/8	7 3/8	48 5/8	441	-	-	-	-
CRN 32-5-2	20	3	230/460	254TC	35 1/4	10 3/8	8 3/4	51 5/8	11 1/2	9	53 1/4	507	-	-	-	-
CRN 32-5	20	3	230/460	254TC	35 1/4	10 3/8	8 3/4	51 5/8	11 1/2	9	53 1/4	507	-	-	-	-
CRN 32-6-2	25	3	230/460	284TSC	38	13	9 1/2	57 3/4	11 1/2	9	59	546	-	-	-	-
CRN 32-6	25	3	230/460	284TSC	38	13	9 1/2	57 3/4	11 1/2	9	59	546	-	-	-	-
CRN 32-7-2	25	3	230/460	284TSC	40 3/4	13	9 1/2	60 1/2	11 1/2	9	61 3/4	555	-	-	-	-
CRN 32-7	30	3	230/460	284TSC	40 3/4	15 3/8	13 1/8	63 3/4	11 1/2	9	62 3/8	601	-	-	-	-
CRN 32-8-2	30	3	230/460	284TSC	43 5/8	15 3/8	13 1/8	66 5/8	11 1/2	9	65 1/4	610	-	-	-	-
CRN 32-8	30	3	230/460	284TSC	43 5/8	15 3/8	13 1/8	66 5/8	11 1/2	9	65 1/4	610	-	-	-	-
CRN 32-9-2	40	3	230/460	286TSC	46 3/8	15 3/8	13 1/8	69 3/8	13 1/4	12 1/4	69 3/8	696	-	-	-	-
CRN 32-9	40	3	230/460	286TSC	46 3/8	15 3/8	13 1/8	69 3/8	13 1/4	12 1/4	69 3/8	696	-	-	-	-
CRN 32-10-2	40	3	230/460	286TSC	49 1/8	15 3/8	13 1/8	72 1/8	13 1/4	12 1/4	72 1/8	705	-	-	-	-
CRN 32-10	40	3	230/460	286TSC	49 1/8	15 3/8	13 1/8	72 1/8	13 1/4	12 1/4	72 1/8	705	-	-	-	-
CRN 32-11-2	40	3	230/460	286TSC	51 7/8	15 3/8	13 1/8	74 7/8	13 1/4	12 1/4	74 7/8	731	-	-	-	-

Weights based on pump with TEFC motor (see price list for individual weights)
All dimensions in inches unless otherwise noted.

Performance curves

CR(E), CRN(E) 45

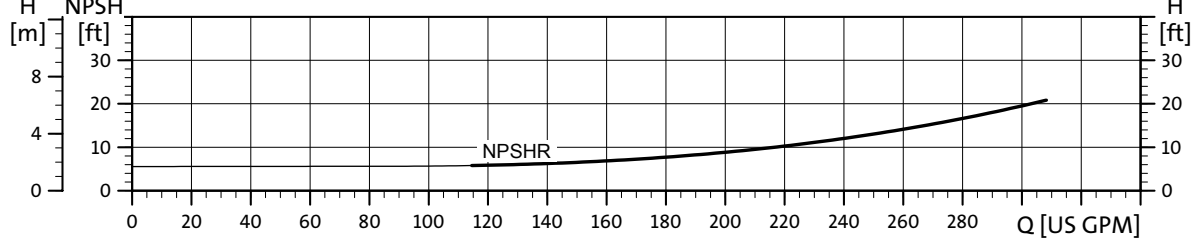
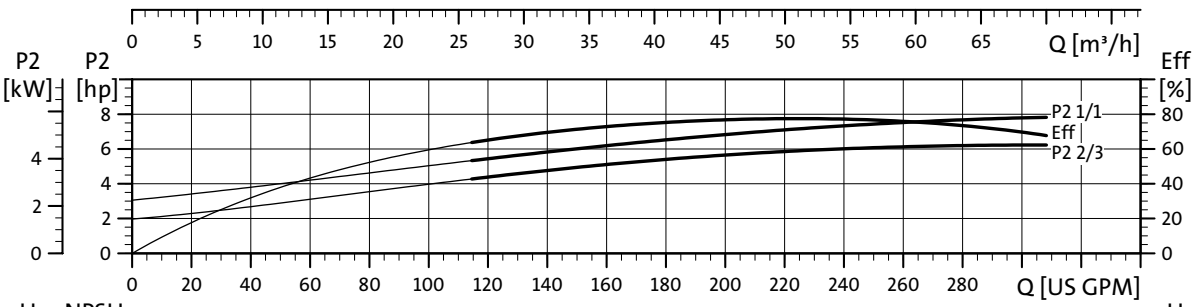
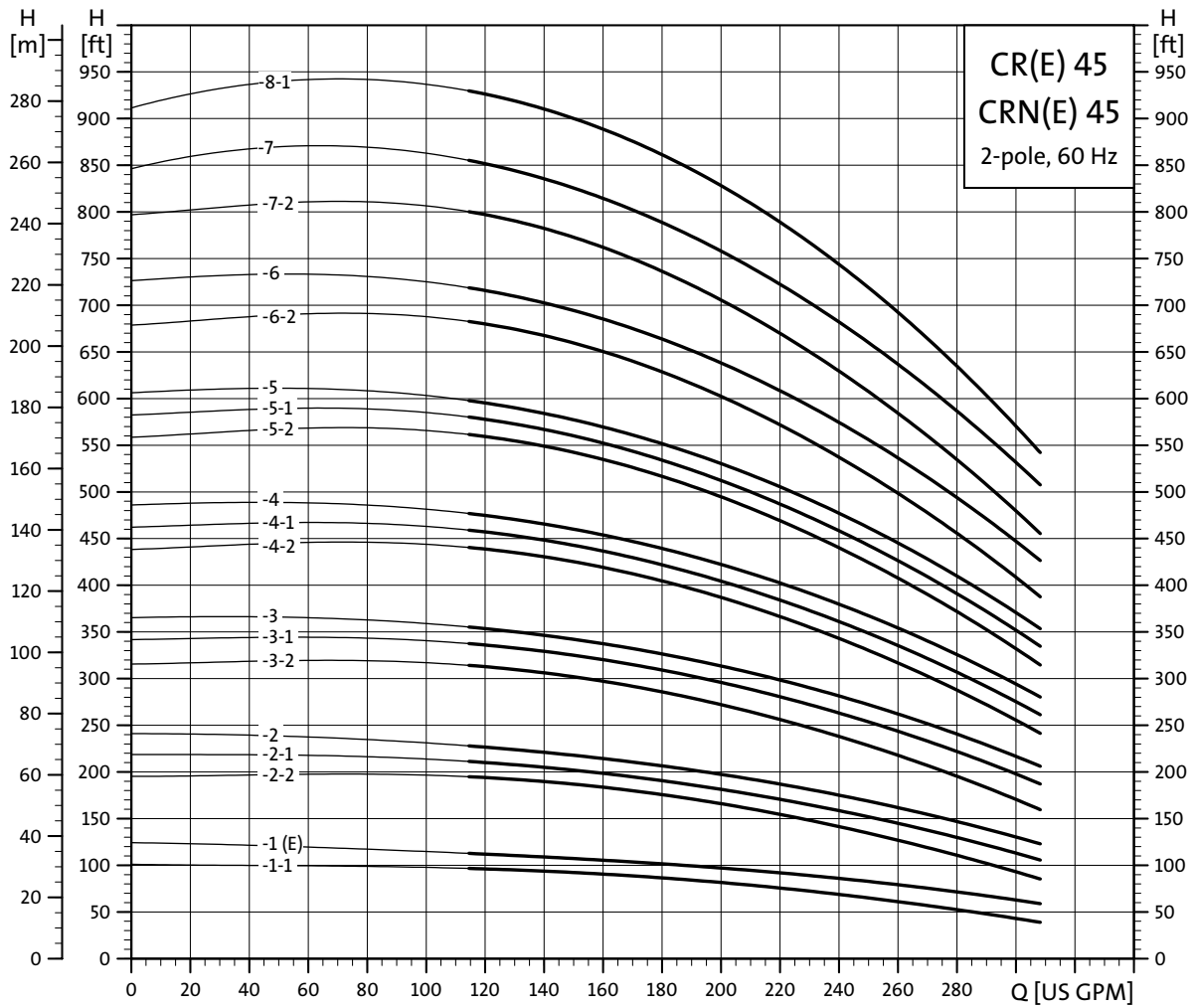

E03 TM02.0040.1303

Dimensional sketches

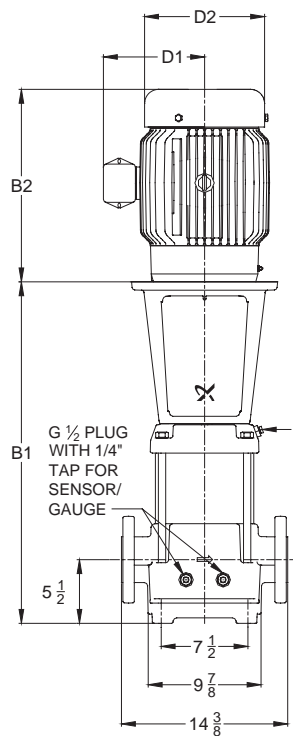

STAGES 4-1 to 8-1

3" ANSI
250 LB R.F.

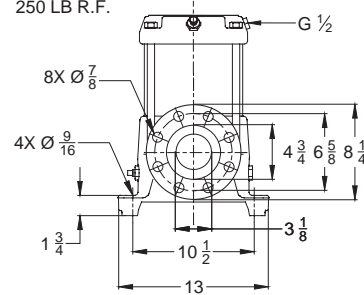

STAGES 1-1 to 4-2

3" ANSI
125 LB R.F.

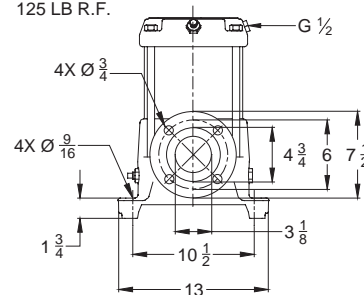

TM027700 3804

Dimensions and weights

Pump type	Hp	Ph	Voltage	NEMA Frame size	ANSI B1	TEFC			ODP			ANSI Ship Wt. ¹ [lbs.]	MLE			ANSI Ship Wt. ¹ [lbs.]
						D1	D2	ANSI B1+B2	D1	D2	ANSI B1+B2		D1	D2	ANSI B1+B2	
CR 45-1-1	7 1/2	1	208-230	213TC	22	10 1/4	7 1/2	37 3/8	-	-	-	301	-	-	-	-
		3	208-230/460	213TC	22	8 3/4	5 3/8	37 5/8	-	-	-	281	-	-	-	-
CR(E) 45-1	7 1/2	1	208-230	213TC	22	10 1/4	7 1/2	37 3/8	-	-	-	301	-	-	-	-
		3	208-230/460	213TC	22	8 3/4	5 3/8	37 5/8	-	-	-	281	8 3/4	7 1/2	37 2/5	311
CR 45-2-2	15	3	208-230/460	254TC	29 1/2	10 3/8	8 3/4	46 1/8	10 5/8	7 3/8	45 5/8	387	-	-	-	-
CR 45-2-1	15	3	208-230/460	254TC	29 1/2	10 3/8	8 3/4	46 1/8	10 5/8	7 3/8	45 5/8	387	-	-	-	-
CR 45-2	15	3	208-230/460	254TC	29 1/2	10 3/8	8 3/4	46 1/8	10 5/8	7 3/8	45 5/8	387	-	-	-	-
CR 45-3-2	20	3	230/460	254TC	32 5/8	10 3/8	8 3/4	49	11 1/2	9	50 5/8	569	-	-	-	-
CR 45-3-1	25	3	230/460	284TSC	32 5/8	13	9 1/2	52 3/8	11 1/2	9	53 5/8	622	-	-	-	-
CR 45-3	25	3	230/460	284TSC	32 5/8	13	9 1/2	52 3/8	11 1/2	9	53 5/8	622	-	-	-	-
CR 45-4-2	30	3	230/460	284TSC	35 3/4	15 3/8	13 1/8	58 3/4	11 1/2	9	57 3/8	809	-	-	-	-
CR 45-4-1	30	3	230/460	284TSC	35 3/4	15 3/8	13 1/8	58 3/4	11 1/2	9	57 3/8	809	-	-	-	-
CR 45-4	30	3	230/460	284TSC	35 3/4	15 3/8	13 1/8	58 3/4	11 1/2	9	57 3/8	809	-	-	-	-
CR 45-5-2	40	3	230/460	286TSC	39	15 3/8	13 1/8	62	13 1/4	12 1/4	62	863	-	-	-	-
CR 45-5-1	40	3	230/460	286TSC	39	15 3/8	13 1/8	62	13 1/4	12 1/4	62	863	-	-	-	-
CR 45-5	40	3	230/460	286TSC	39	15 3/8	13 1/8	62	13 1/4	12 1/4	62	863	-	-	-	-
CR 45-6-2	50	3	230/460	324TSC	42 1/8	17	14 1/8	69 3/4	13 3/8	12 1/4	64 5/8	929	-	-	-	-
CR 45-6	50	3	230/460	324TSC	42 1/8	17	14 1/8	69 3/4	13 3/8	12 1/4	64 5/8	929	-	-	-	-
CR 45-7-2	50	3	230/460	324TSC	45 1/4	17	14 1/8	72 7/8	13 3/8	12 1/4	67 3/4	938	-	-	-	-
CR 45-7	60	3	230/460	364TSC	45 1/4	19	15	75 7/8	15 1/4	13 1/4	71 1/4	1113	-	-	-	-
CR 45-8-1	60	3	230/460	364TSC	48 3/8	19	15	79	15 1/4	13 1/4	74 3/8	1113	-	-	-	-

Weights based on pump with TEFC motor (see price list for individual weights)
All dimensions in inches unless otherwise noted.

Dimensional sketches

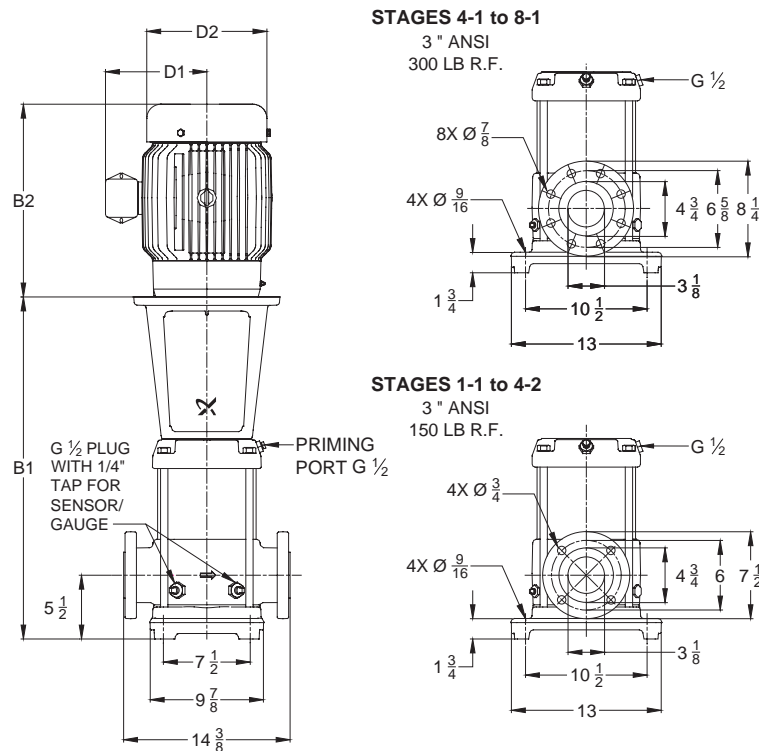

TM027704 3804

Dimensions and weights

Pump type	Hp	Ph	Voltage	NEMA Frame size	ANSI B1	TEFC			ODP			ANSI Ship Wt. ¹ [lbs.]	MLE			ANSI Ship Wt. ¹ [lbs.]
						D1	D2	ANSI B1+B2	D1	D2	ANSI B1+B2		D1	D2	ANSI B1+B2	
CRN 45-1-1	7 1/2	1	208-230	213TC	22	10 1/4	7 1/2	37 3/8	-	-	-	301	-	-	-	-
			208-230/460	213TC	22	8 3/4	5 3/8	37 5/8	-	-	-	281	-	-	-	-
CRN 45-1	7 1/2	3	208-230	213TC	22	10 1/4	7 1/2	37 3/8	-	-	-	301	-	-	-	-
			208-230/460	213TC	22	8 3/4	5 3/8	37 5/8	-	-	-	281	8 3/4	7 1/2	37 2/5	311
CRN 45-2-2	15	3	208-230/460	254TC	29 1/2	10 3/8	8 3/4	46 1/8	10 5/8	7 3/8	45 5/8	387	-	-	-	-
CRN 45-2-1	15	3	208-230/460	254TC	29 1/2	10 3/8	8 3/4	46 1/8	10 5/8	7 3/8	45 5/8	387	-	-	-	-
CRN 45-2	15	3	208-230/460	254TC	29 1/2	10 3/8	8 3/4	46 1/8	10 5/8	7 3/8	45 5/8	387	-	-	-	-
CRN 45-3-2	20	3	230/460	254TC	32 5/8	10 3/8	8 3/4	49	11 1/2	9	50 5/8	569	-	-	-	-
CRN 45-3-1	25	3	230/460	284TSC	32 5/8	13	9 1/2	52 3/8	11 1/2	9	53 5/8	622	-	-	-	-
CRN 45-3	25	3	230/460	284TSC	32 5/8	13	9 1/2	52 3/8	11 1/2	9	53 5/8	622	-	-	-	-
CRN 45-4-2	30	3	230/460	284TSC	35 3/4	15 3/8	13 1/8	58 3/4	11 1/2	9	57 3/8	809	-	-	-	-
CRN 45-4-1	30	3	230/460	284TSC	35 3/4	15 3/8	13 1/8	58 3/4	11 1/2	9	57 3/8	809	-	-	-	-
CRN 45-4	30	3	230/460	284TSC	35 3/4	15 3/8	13 1/8	58 3/4	11 1/2	9	57 3/8	809	-	-	-	-
CRN 45-5-2	40	3	230/460	286TSC	39	15 3/8	13 1/8	62	13 1/4	12 1/4	62	863	-	-	-	-
CRN 45-5-1	40	3	230/460	286TSC	39	15 3/8	13 1/8	62	13 1/4	12 1/4	62	863	-	-	-	-
CRN 45-5	40	3	230/460	286TSC	39	15 3/8	13 1/8	62	13 1/4	12 1/4	62	863	-	-	-	-
CRN 45-6-2	50	3	230/460	324TSC	42 1/8	17	14 1/8	69 3/4	13 3/8	12 1/4	64 5/8	929	-	-	-	-
CRN 45-6	50	3	230/460	324TSC	42 1/8	17	14 1/8	69 3/4	13 3/8	12 1/4	64 5/8	929	-	-	-	-
CRN 45-7-2	50	3	230/460	324TSC	45 1/4	17	14 1/8	72 7/8	13 3/8	12 1/4	67 3/4	938	-	-	-	-
CRN 45-7	60	3	230/460	364TSC	45 1/4	19	15	75 7/8	15 1/4	13 1/4	71 1/4	1113	-	-	-	-
CRN 45-8-1	60	3	230/460	364TSC	48 3/8	19	15	79	15 1/4	13 1/4	74 3/8	1113	-	-	-	-

Weights based on pump with TEFC motor (see price list for individual weights)
All dimensions in inches unless otherwise noted.

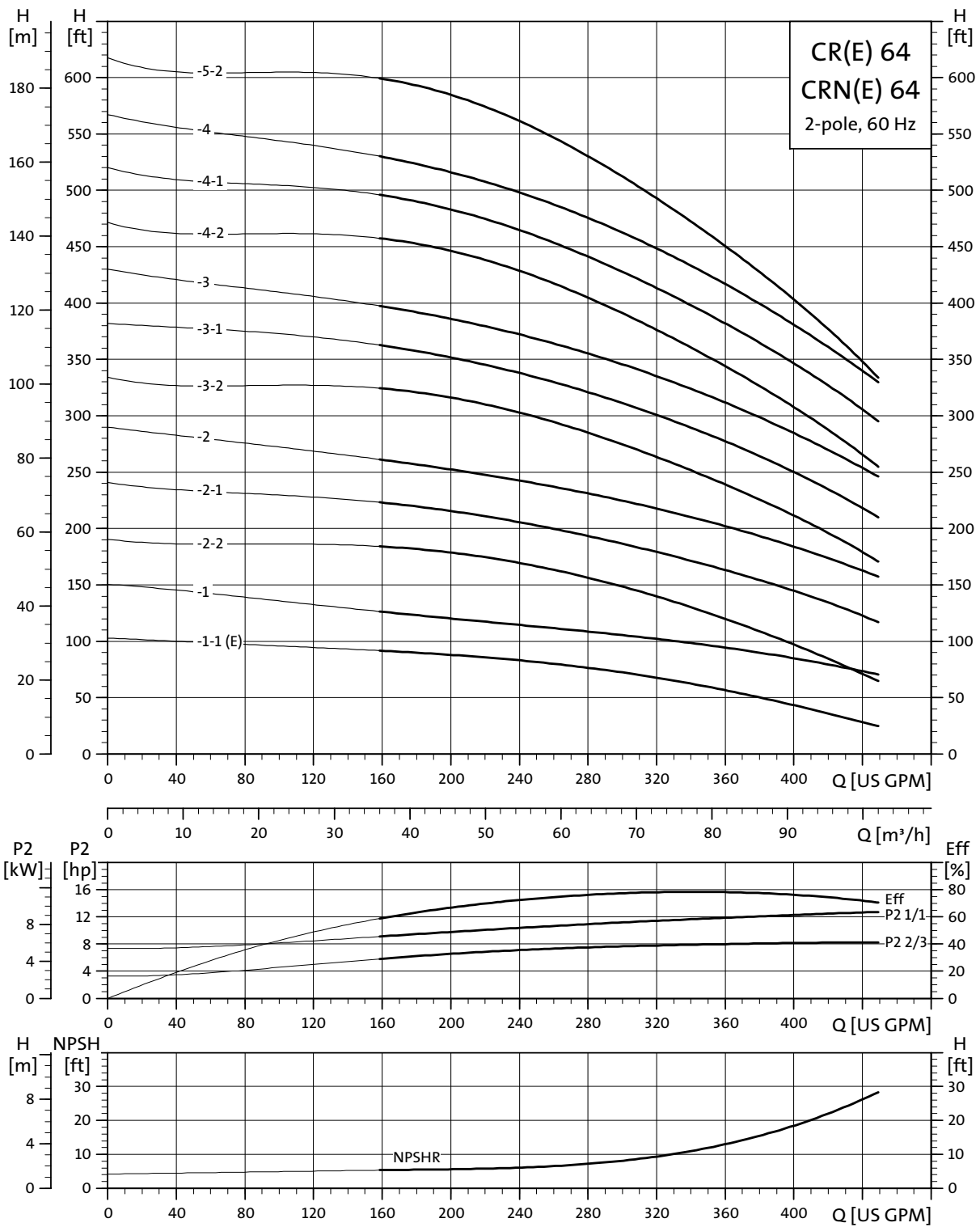

TMO2.0041.3804

Dimensional sketches

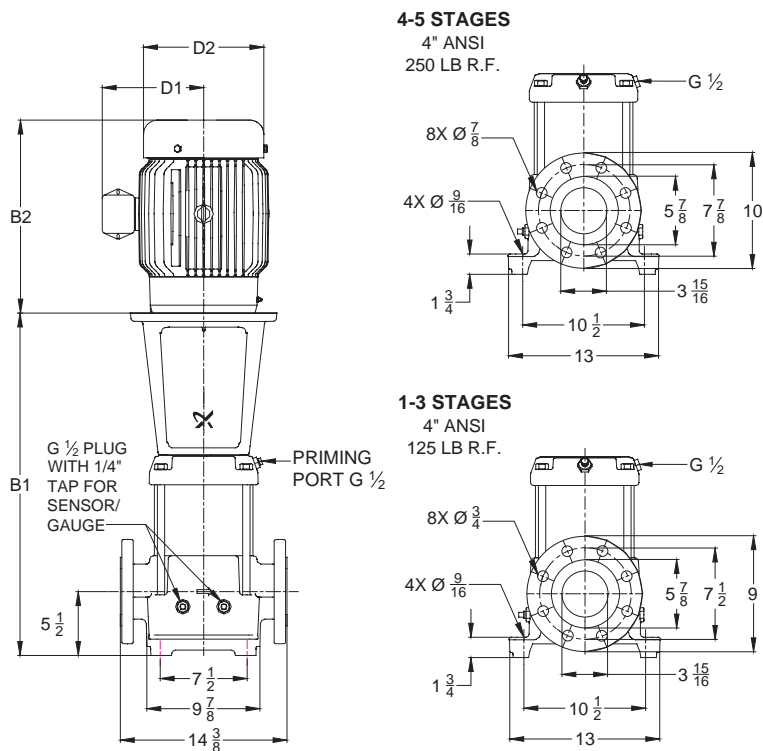

TM0277013804

Dimensions and weights

Pump type	Hp	Ph	Voltage	NEMA Frame size	ANSI B1	TEFC			ODP			ANSI Ship Wt. ¹ [lbs.]	MLE			ANSI Ship Wt. ¹ [lbs.]
						D1	D2	ANSI B1+B2	D1	D2	ANSI B1+B2		D1	D2	ANSI B1+B2	
CR(E) 64-1-1	7 1/2	1	208-230	213TC	22 1/8	10 1/4	7 1/2	37 1/2	-	-	-	299	-	-	-	-
		3	208-230/460	213TC	22 1/8	8 3/4	5 3/8	37 3/4	-	-	-	277	8 3/4	7 1/2	37 1/2	307
CR 64-1	15	3	208-230/460	254TC	26 1/2	10 3/8	8 3/4	43 1/8	10 5/8	7 3/8	42 5/8	339	-	-	-	-
CR 64-2-2	15	3	208-230/460	254TC	29 3/4	10 3/8	8 3/4	46 3/8	10 5/8	7 3/8	45 7/8	348	-	-	-	-
CR 64-2-1	20	3	230/460	254TC	29 3/4	10 3/8	8 3/4	46 1/8	11 1/2	9	47 3/4	391	-	-	-	-
CR 64-2	25	3	230/460	284TSC	29 3/4	13	9 1/2	49 1/2	11 1/2	9	50 3/4	514	-	-	-	-
CR 64-3-2	30	3	230/460	284TSC	33	15 3/8	13 1/8	56	11 1/2	9	54 5/8	569	-	-	-	-
CR 64-3-1	40	3	230/460	286TSC	33	15 3/8	13 1/8	56	13 1/4	12 1/4	56	647	-	-	-	-
CR 64-3	40	3	230/460	286TSC	33	15 3/8	13 1/8	56	13 1/4	12 1/4	56	647	-	-	-	-
CR 64-4-2	40	3	230/460	286TSC	36 1/4	15 3/8	13 1/8	59 1/4	13 1/4	12 1/4	59 1/4	684	-	-	-	-
CR 64-4-1	50	3	230/460	324TSC	36 1/4	17	14 1/8	63 7/8	13 3/8	12 1/4	58 3/4	748	-	-	-	-
CR 64-4	50	3	230/460	324TSC	36 1/4	17	14 1/8	63 7/8	13 3/8	12 1/4	58 3/4	748	-	-	-	-
CR 64-5-2	60	3	230/460	364TSC	39 1/2	19	15	70 1/8	15 1/4	13 1/4	65 1/2	923	-	-	-	-

Weights based on pump with TEFC motor (see price list for individual weights)
All dimensions in inches unless otherwise noted.

Dimensional sketches

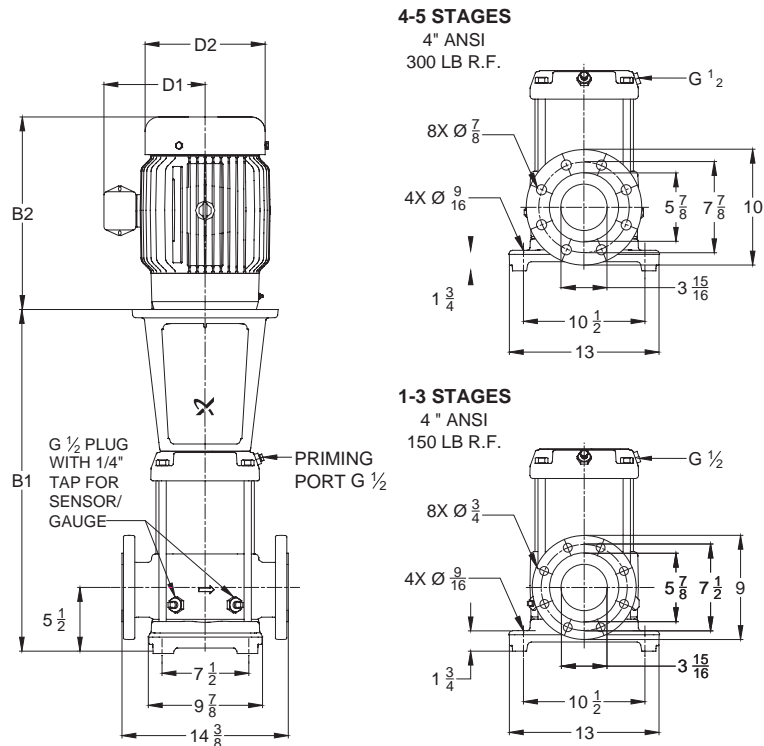

TMO27705 3804

Dimensions and weights

Pump type	Hp	Ph	Voltage	NEMA Frame size	ANSI B1	TEFC			ODP			ANSI Ship Wt. ¹ [lbs.]	MLE			ANSI Ship Wt. ¹ [lbs.]
						D1	D2	ANSI B1+B2	D1	D2	ANSI B1+B2		D1	D2	ANSI B1+B2	
64-1-1	7 1/2	1	208-230	213TC	22 1/8	10 1/4	7 1/2	37 1/2	-	-	-	299	-	-	-	-
		3	208-230/460	213TC	22 1/8	8 3/4	5 3/8	37 3/4	-	-	-	277	8 3/4	7 1/2	37 1/2	307
CRN(E) 64-1	15	3	208-230/460	254TC	26 1/2	10 3/8	8 3/4	43 1/8	10 5/8	7 3/8	42 5/8	339	-	-	-	-
CRN 64-2-2	15	3	208-230/460	254TC	29 3/4	10 3/8	8 3/4	46 3/8	10 5/8	7 3/8	45 7/8	348	-	-	-	-
CRN 64-2-1	20	3	230/460	254TC	29 3/4	10 3/8	8 3/4	46 1/8	11 1/2	9	47 3/4	391	-	-	-	-
CRN 64-2	25	3	230/460	284TSC	29 3/4	13	9 1/2	49 1/2	11 1/2	9	50 3/4	514	-	-	-	-
CRN 64-3-2	30	3	230/460	284TSC	33	15 3/8	13 1/8	56	11 1/2	9	54 5/8	569	-	-	-	-
CRN 64-3-1	40	3	230/460	286TSC	33	15 3/8	13 1/8	56	13 1/4	12 1/4	56	647	-	-	-	-
CRN 64-3	40	3	230/460	286TSC	33	15 3/8	13 1/8	56	13 1/4	12 1/4	56	647	-	-	-	-
CRN 64-4-2	40	3	230/460	286TSC	36 1/4	15 3/8	13 1/8	59 1/4	13 1/4	12 1/4	59 1/4	684	-	-	-	-
CRN 64-4-1	50	3	230/460	324TSC	36 1/4	17	14 1/8	63 7/8	13 3/8	12 1/4	58 3/4	748	-	-	-	-
CRN 64-4	50	3	230/460	324TSC	36 1/4	17	14 1/8	63 7/8	13 3/8	12 1/4	58 3/4	748	-	-	-	-
CRN 64-5-2	60	3	230/460	364TSC	39 1/2	19	15	70 1/8	15 1/4	13 1/4	65 1/2	923	-	-	-	-

Weights based on pump with TEFC motor (see price list for individual weights)
All dimensions in inches unless otherwise noted.

Performance curves

CR, CRN 90

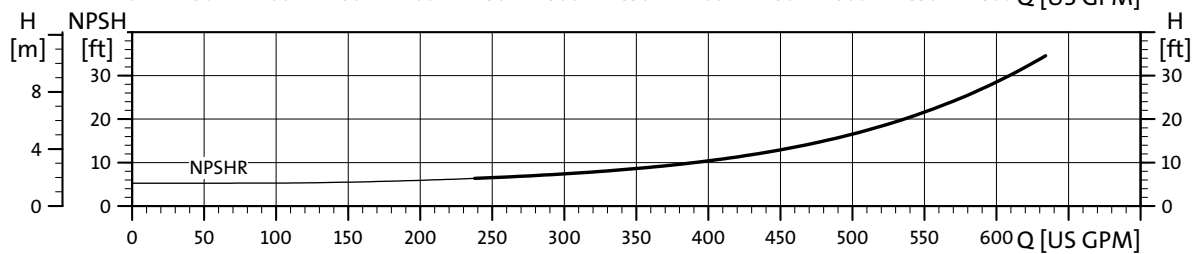
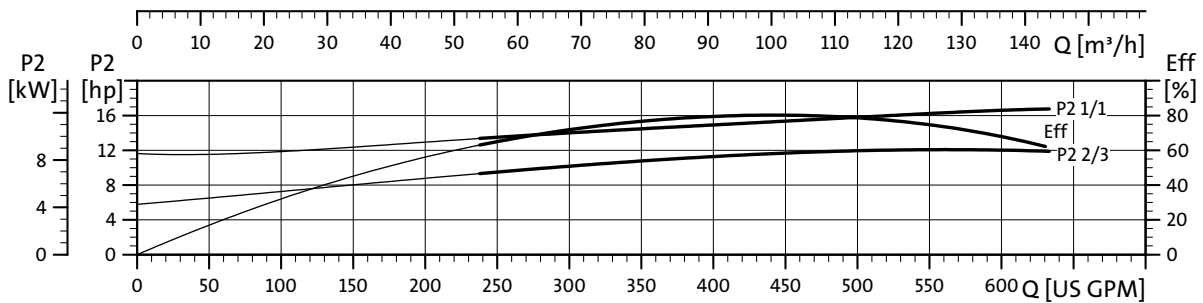
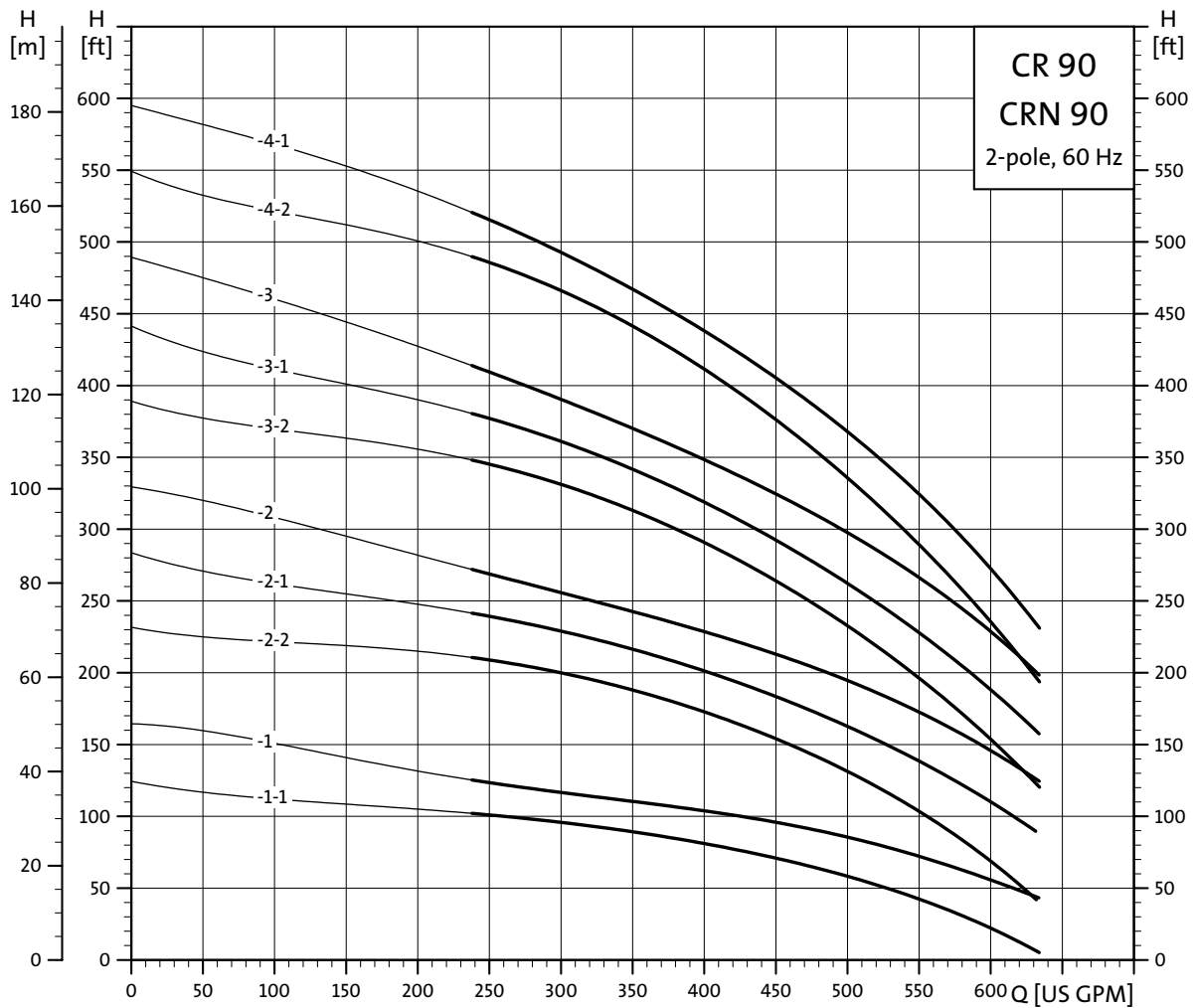

TM02.0042.1303

Dimensional sketches

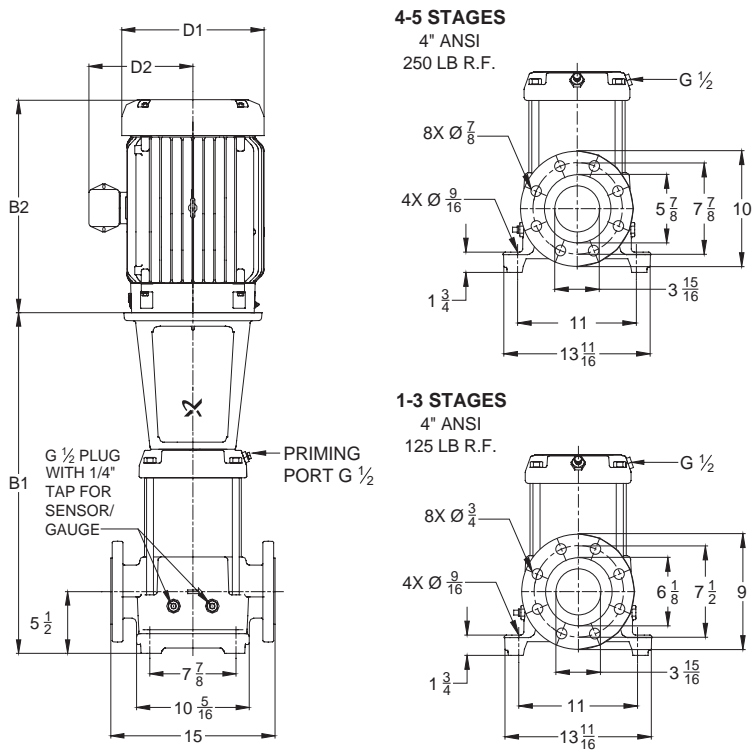

TM027702 3804

Dimensions and weights

Pump type	Hp	Ph	Voltage	NEMA Frame size	ANSI B1	TEFC			ODP			ANSI Ship Wt. ¹ [lbs.]
						D1	D2	ANSI B1+B2	D1	D2	ANSI B1+B2	
CR 90-1-1	15	3	208-230/460	254TC	26 7/8	10 3/8	8 3/4	43 1/2	10 5/8	7 3/8	43	351
CR 90-1	15	3	208-230/460	254TC	26 7/8	10 3/8	8 3/4	43 1/2	10 5/8	7 3/8	43	351
CR 90-2-2	25	3	230/460	284TSC	30 1/2	13	9 1/2	50 1/4	11 1/2	9	51 1/2	527
CR 90-2-1	30	3	230/460	284TSC	30 1/2	15 3/8	13 1/8	53 1/2	11 1/2	9	52 1/8	573
CR 90-2	40	3	230/460	286TSC	30 1/2	15 3/8	13 1/8	53 1/2	13 1/4	12 1/4	53 1/2	650
CR 90-3-2	40	3	230/460	286TSC	34 1/8	15 3/8	13 1/8	57 1/8	13 1/4	12 1/4	57 1/8	660
CR 90-3-1	50	3	230/460	324TSC	34 1/8	17	14 1/8	61 3/4	13 3/8	12 1/4	56 5/8	724
CR 90-3	50	3	230/460	324TSC	34 1/8	17	14 1/8	61 3/4	13 3/8	12 1/4	56 5/8	752
CR 90-4-2	60	3	230/460	364TSC	37 3/4	19	15	68 3/8	15 1/4	13 1/4	63 3/4	870
CR 90-4-1	60	3	230/460	364TSC	37 3/4	19	15	68 3/8	15 1/4	13 1/4	63 3/4	870

Weights based on pump with TEFC motor (see price list for individual weights)
All dimensions in inches unless otherwise noted.

Dimensional sketches

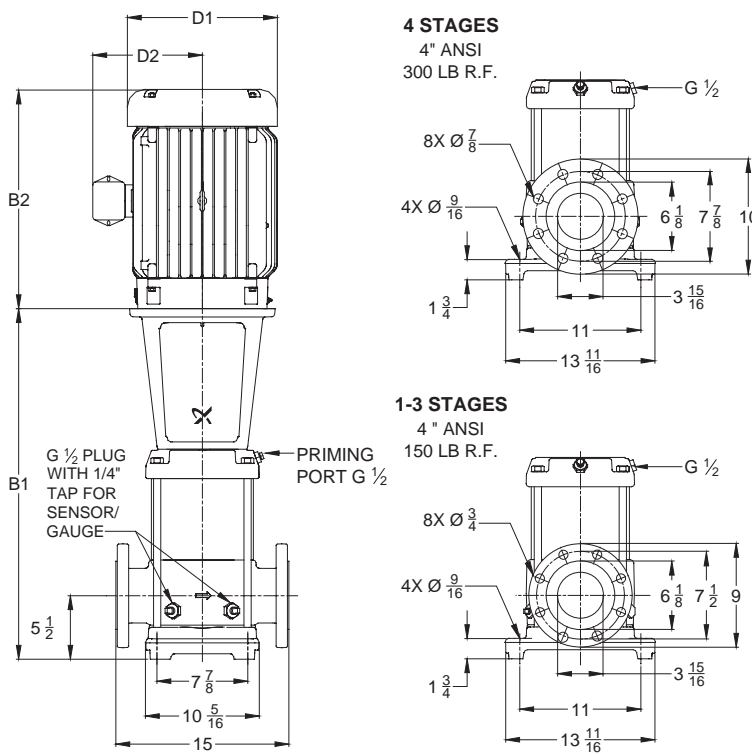

TM027706 3804

Dimensions and weights

Pump type	Hp	Ph	Voltage	NEMA Frame size	ANSI B1	TEFC			ODP			ANSI Ship Wt. ¹ [lbs.]
						D1	D2	ANSI B1+B2	D1	D2	ANSI B1+B2	
CRN 90-1-1	15	3	208-230/460	254TC	26 7/8	10 3/8	8 3/4	43 1/2	10 5/8	7 3/8	43	351
CRN 90-1	15	3	208-230/460	254TC	26 7/8	10 3/8	8 3/4	43 1/2	10 5/8	7 3/8	43	351
CRN 90-2-2	25	3	230/460	284TSC	30 1/2	13	9 1/2	50 1/4	11 1/2	9	51 1/2	527
CRN 90-2-1	30	3	230/460	284TSC	30 1/2	15 3/8	13 1/8	53 1/2	11 1/2	9	52 1/8	573
CRN 90-2	40	3	230/460	286TSC	30 1/2	15 3/8	13 1/8	53 1/2	13 1/4	12 1/4	53 1/2	650
CRN 90-3-2	40	3	230/460	286TSC	34 1/8	15 3/8	13 1/8	57 1/8	13 1/4	12 1/4	57 1/8	660
CRN 90-3-1	50	3	230/460	324TSC	34 1/8	17	14 1/8	61 3/4	13 3/8	12 1/4	56 5/8	724
CRN 90-3	50	3	230/460	324TSC	34 1/8	17	14 1/8	61 3/4	13 3/8	12 1/4	56 5/8	752
CRN 90-4-2	60	3	230/460	364TSC	37 3/4	19	15	68 3/8	15 1/4	13 1/4	63 3/4	870
CRN 90-4-1	60	3	230/460	364TSC	37 3/4	19	15	68 3/8	15 1/4	13 1/4	63 3/4	870

Weights based on pump with TEFC motor (see price list for individual weights)
All dimensions in inches unless otherwise noted.

Motor data

Vertical multistage centrifugal pumps

TEFC motors

(Totally Enclosed Fan Cooled, constant speed)

HP	PH	Frame	S.F.	Voltage [V]	Mtr. Eff. [%]	Insul. class	KVA code	Full load current [A]	Service Factor current [A]	Start current [A]	Motor type
1/3	1	56C	1.35	115/230	55	B	K	6.0/3.0	7.6/3.8	28/14	Baldor
	3	56C	1.35	208-230/460	78.5/80	F	L	1.12-1.1/0.55	1.5-1.45/0.75	7.1-10.2/3.9	ML
1/2	1	56C	1.6	115/208-230	62	B	K	7.4/4.1-3.7	9.8/5.2-4.9	39/21.6-19.5	Baldor
	3	56C	1.25	208-230/460	78/79.5	F	K	1.64-1.55/0.78	2.0-1.9/0.95	9.7-10.1/5.1	ML
3/4	1	56C	1.25	115/208-230	66	B	K	9.6/5.3-4.8	11.4/6.0-5.7	56/31-28	Baldor
	3	56C	1.25	208-230/460	79/80	F	K	2.4-2.3/1.2	2.9-2.75/1.4	14.2-15/7.8	ML
1	1	56C	1.25	115/230	66	B	K	12/6.0	14.4/7.2	77/38.5	Baldor
	3	56C	1.25	208-230/460	81/81	F	J	3.25-3.35/1.68	4.0-3.9/1.95	19.2-21.8/10.9	ML
1 1/2	1	56C	1.3	115/208-230	71	B	K	17/9.5-8.6	20.4/11.3-10.2	106/58.6-53	Baldor
	3	56C	1.15	208-230/460	83/84	F	M	4.7-4.6/2.3	5.2-5.1/2.55	33.8-36.8/18.4	ML
2	1	56C	1.15	115/230	74	F	K	23/11.5	25.4/12.7	156/78	Baldor
	3	56C	1.15	208-230/460	84.5/85.5	F	G	5.7-5.4/2.7	6.55-6.1/3.05	46.2-48.6/24.3	ML
3	1	182TC	1.15	115/208-230	75	F	H	29/16-14.5	31.8/18-15.9	170/94-85	Baldor
	3	182TC	1.15	208-230/460	82.5/84	F	K	8.9-8.5/4.25	10.4-9.5/4.75	60.5-63.8/31.9	ML
5	1	213TC	1.15	208-230	80	F	J	24-22	27-25	188-170	Baldor
	3	184TC	1.15	208-230/460	84.5/86	F	S	14.2-14.0/7.0	16-15.4/7.7	109-119/59.5	ML
7 1/2	1	213TC	1.15	208-230	82	F	F	33.8-31	38.5-35.5	244-220	Baldor
	3	213TC	1.15	208-230/460	86/87.5	F	M	21-21.5/10.8	24-23.5/11.8	162-183/93	ML
10	1	213TC	1.15	230	85.5	F	F	40	46	284	Baldor
	3	213TC	1.15	208-230/460	89/89.5	F	L	28-28.5/14.4	32-31.5/16	241-271/137	ML
15	3	254TC	1.15	208-230/460	86.5	H	L	38-34/17	43.4-39/19.5	376-340/170	Baldor
20	3	254TC	1.15	230/460	88.5	F	K	46/23	52.4/26.2	420/210	Baldor
25	3	284TSC	1.15	230/460	91.7	F	J	57/28.5	66/33	498/249	Baldor
30	3	286TSC	1.15	230/460	91	F	G	68/34	78/39	450/225	Baldor
40	3	286TSC	1.15	230/460	90.2	F	H	90/45	104/52	644/322	Baldor
50	3	326TSC	1.15	230/460	93	F	G	110/55	128/64	746/393	Baldor
60	3	364TSC	1.15	230/460	93	F	G	134/67	154/77	918/459	Baldor



TM02 7696 3803



CR 7845

Notes:

- The information in this chart applies to **Grundfos' ML motors and Grundfos specified Baldor® motors.**

ML motors: Three-phase, 0.33-10 hp

Baldor motors: Single-phase, 0.33-10 hp and
Three-phase, 15-60 hp.

Grundfos CR pumps are supplied with heavy-duty 2-pole, NEMA C-frame motors built or selected to our rigid specifications. All CR pump motors have heavy-duty bearings in them for maximum thrust requirements.

It is not recommended that an off-the-shelf standard Baldor motor be used on a Grundfos pump. Ideally, the best motor choice would be the Grundfos specified motor.

- Other motor types are available (i.e., Explosion proof, Mill and Chem duty, High Efficiency, etc.), consult local Grundfos company for more information.

- Pumps supplied by Grundfos Canada are normally supplied with motors from other manufactures. 575 volt motors meet EAct/NRC efficiency standards. Dimensions and data will vary, contact local Grundfos company for more information.
- All values are subject to change without notice.

MLE motors

(Integrated variable frequency drive)

HP	PH	Frame	S.F.	Voltage	Mtr. Eff. %	Insul. class	Full load current	Service Factor current
1/2	1	56C	1.0	208-230	71	F	2.8	-
3/4	1	56C	1.0	208-230	74	F	3.9	-
1	1	56C	1.0	208-230	76	F	5.2	-
	3	56C	1.25	460-480	70	F	1.7	2.1
1 1/2	1	56C	1.0	208-230	77	F	7.5	-
	3	56C	1.15	460-480	80	F	2.15	2.5
2	3	56C	1.15	460-480	82	F	2.7	3.1
	3	182TC	1.15	460-480	84	F	3.7	4.3
5	3	184TC	1.15	460-480	85	F	6.1	7.0
7 1/2	3	215TC	1.15	460-480	85	F	8.9	10.3
10	3	215TC	1.15	460-480	86	F	12.0	13.8

Note: MTR Eff. Is the total efficiency for the motor and variable frequency drive.



GR 8972_P

ODP motors

(Open Drip Proof, constant speed)

HP	PH	ODP Frame	ODP S.F.	ODP Voltage	ODP Mtr. Eff. %	ODP Insul. class	ODP KVA code	ODP Full load current	ODP service Factor current	ODP Start current
15	3	254TC	1.15	208-230/460	85.5	F	G	38-36/18	43-41/20.5	290-262/131
20	3	254TC	1.15	230/460	90.2	B	G	48/24	55/27.5	306/153
25	3	284TSC	1.15	230/460	91	B	G	59/29.5	67/33.5	374/187
30	3	284TSC	1.15	230/460	91	F	H	70/35	80/40	480/240
40	3	286TSC	1.15	230/460	91	B	G	96/48	110/55	542/271
50	3	324TSC	1.15	230/460	92.4	F	G	116/58	134/67	732/366
60	3	364TSC	1.15	230/460	91.7	F	G	140/70	161/80.5	914/457



TM02 7696

Notes:

- The information in this chart applies to **Grundfos' MLE motors and Grundfos specified Baldor® motors.**

MLE motors: Single-phase, 0.5-1.5 hp
Three-phase, 1.0-10 hp
Baldor motors: Three-phase, 15-60 hp.

Grundfos CR pumps are supplied with heavy-duty 2-pole, NEMA C-frame motors built or selected to our rigid specifications. All CR pump motors have heavy-duty bearings in them for maximum thrust requirements.

It is not recommended that an off-the-shelf standard Baldor motor be used on a Grundfos pump. Ideally, the best motor choice would be the Grundfos specified motor.

- Other motor types are available (i.e., Explosion proof, Mill and Chem duty, High Efficiency, etc.), consult local Grundfos company for more information.

- Pumps supplied by Grundfos Canada are normally supplied with motors from other manufactures. 575 volt motors meet EAct/NRC efficiency standards. Dimensions and data will vary, contact local Grundfos company for more information.
- All values are subject to change without notice.

Pumped liquids

Thin, non-explosive liquids, not containing solid particles or fibers. The liquid must not chemically attack the pump materials. When pumping liquids with a density and/or viscosity higher than that of water, oversized motors must be used, if required.

Whether a pump is suitable for a particular liquid depends on a number of factors of which the most important are the chloride content, pH value, temperature and content of chemicals, oils, etc.

Please note that aggressive liquids (e.g. sea water and some acids) may attack or dissolve the protective oxide film of the stainless steel and thus cause corrosion. The CR(E), CRI(E), CRN(E) pump types are suitable for the following liquids:

CR(E), CRI(E)

- Non-corrosive liquids.

For liquid transfer, circulation and pressure boosting of cold or hot clean water.

CRN(E)

- Industrial liquids.

In systems where all parts in contact with the liquid must be made of high-grade stainless steel.

CRT(E)

- Saline liquids.
- Hypochlorites.
- Acids.

For saline or chloride-containing liquids such as sea water or oxidizing agents such as hypochlorites, CRT(E) pumps of titanium are available. See separate data booklet on CRT(E).

List of pumped liquids

A number of typical liquids are listed on the following pages.

Other pump versions may be applicable, but those stated in the list are considered to be the best choices. The table is intended as a general guide only, and cannot replace actual testing of the pumped liquids and pump materials under specific working conditions.

The list should, however, be applied with some caution as factors such as

- concentration of the pumped liquid,
- liquid temperature or
- pressure.

may affect the chemical resistance of a specific pump version.

Safety precautions must be made when pumping dangerous liquids.

Notes

D	Often with additives.
E	Density and/or viscosity differ from that of water. Allow for this when calculating motor output and pump performance.
F	Pump selection depends on many factors. Contact Grundfos.
H	Risk of crystallization/precipitation in shaft seal
1	The pumped liquid highly inflammable.
2	The pumped liquid is combustible.
3	Insoluble in water.
4	Low self-ignition point.

Pumped liquids

Vertical multistage centrifugal pumps

Pumped liquid	Note	Liquid concentration, liquid temperature	CR			CRN		
			1s, 1, 3, 5	10, 15, 20	32, 45, 64, 90	1s, 1, 3, 5	10, 15, 20	32, 45, 64, 90
Acetic acid CH ₃ COOH		5%, 68°F				HQQE	HQQE	KUHE
Acetone CH ₃ COCH ₃	1, F	100%, 68°F				HQQE	HQQE	KUBE
Alkaline degreasing agent	D, F		HQQE	HQQE	KUHE			
Ammonium bicarbonate NH ₄ HCO ₃	E	20%, 86°F				HQQE	HQQE	KUHE
Ammonium hydroxide NH ₄ OH		20%, 104°F	HQQE	HQQE	KUHE			
Aviation fuel	1, 3, 4, F	100%, 68°F	HQBV	HQBV	KUBV			
Benzoic acid C ₆ H ₅ COOH	H	0,5%, 68°F				HQQV	HQQV	KUHV
Boiler water		<248°F	HQQE	HQQE	KUBE			
	F	248°F - 356°F	-	-	-			
Calcareous water		<194°F	HQQE	HQQE	KUHE			
Calcium acetate (as coolant with inhibitor) Ca(CH ₃ COO) ₂	D, E	30%, 122°F	HQQE	HQQE	KUHE			
Calcium hydroxide Ca(OH) ₂	E	Saturated solution, 122°F	HQQE	HQQE	KUHE			
Chloride-containing water	F	<86°F, max. 500 ppm				HQQE	HQQE	KUHE
Chromic acid H ₂ CrO ₄	H	1%, 68°F				HQQV	HQQV	KUHV
Citric acid HOC(CH ₂ CO ₂ H) ₂ COOH	H	5%, 104°F				HQQE	HQQE	KUHE
Completely desalinated water (demineralized water)		<248°F				HQQE	HQQE	KUHE
Condensate		<194°F	HQQE	HQQE	KUHE			
Copper sulfate CuSO ₄	E	10%, 122°F				HQQE	HQQE	KUHE
Corn oil	D, E, 3	100%, 176°F	HQQV	HQQV	KUHV			
Diesel oil	2, 3, 4, F	100%, 68°F	HQBV	HQBV	KUBV			
Domestic hot water (potable water)		<248°F	HQQE	HQQE	KUBE			
Ethanol (ethyl alcohol) C ₂ H ₅ OH	1, F	100%, 68°F	HQQE	HQQE	KUBE			
Ethylene glycol HOCH ₂ CH ₂ OH	D, E	50%, 122°F	HQQE	HQQE	KUUE			
Formic acid HCOOH		5%, 68°F				HQQE	HQQE	KUHE
Glycerine (glycerol) OHCH ₂ CH(OH)CH ₂ OH	D, E	50%, 122°F	HQQE	HQQE	KUHE			
Hydraulic oil (mineral)	E, 2, 3	100%, 212°F	HQQV	HQQV	KUHV			
Hydraulic oil (synthetic)	E, 2, 3	100%, 212°F	HQQV	HQQV	KUHV			
Isopropyl alcohol CH ₃ CHOHCH ₃	1, F	100%, 68°F	HQQE	HQQE	KUBE			
Lactic acid CH ₃ CH(OH)COOH	E, H	10%, 68°F				HQQV	HQQV	KUHE
Linoleic acid C ₁₇ H ₃₁ COOH	E, 3	100%, 68°F	HQQV	HQQV	KUHV			
Methanol (methyl alcohol) CH ₃ OH	1, F	100%, 68°F	HQQE	HQQE	KUBE			
Motor oil	E, 2, 3	100%, 176°F	HQQV	HQQV	KUHV			
Naphthalene C ₁₀ H ₈	E, H	100%, 176°F	HQQV	HQQV	KUHV			

Pumped liquids

Vertical multistage centrifugal pumps

Pumped liquid	Note	Liquid concentration, liquid temperature	CR			CRN		
			1, 1, 3, 5	10, 15, 20	32, 45, 64, 90	1, 1, 3, 5	10, 15, 20	32, 45, 64, 90
Nitric acid HNO ₃	F	1%, 68°F				HQQE	HQQE	KUHE
Oil-containing water		<212°F	HQQV	HQQV	KUHV			
Olive oil	D, E, 3	100%, 176°F	HQQV	HQQV	KUHV			
Oxalic acid (COOH) ₂	H	1%, 68°F				HQQE	HQQE	KUHE
Ozone-containing water (O ₃)		<212°F				HQQE	HQQE	KUHE
Peanut oil	D, E, 3	100%, 176°F	HQQV	HQQV	KUHV			
Petrol/gasoline	1, 3, 4, F	100%, 68°F	HQBV	HQBV	KUBV			
Phosphoric acid H ₃ PO ₄	E	20%, 68°F				HQQE	HQQE	KUHE
Propanol C ₃ H ₇ OH	1, F	100%, 68°F	HQQE	HQQE	KUHE			
Propylene glycol CH ₃ CH(OH)CH ₂ OH	D, E	50%, 194°F	HQQE	HQQE	KUUE			
Potassium carbonate K ₂ CO ₃	E	20%, 122°F	HQQE	HQQE	KUHE			
Potassium formate (as coolant with inhibitor) KOOCH	D, E	30%, 122°F	HQQE	HQQE	KUHE			
Potassium hydroxide KOH	E	20%, 122°F				HQQE	HQQE	KUHE
Potassium permanganate KMnO ₄		5%, 68°F				HQQE	HQQE	KUHE
Rape seed oil	D, E, 3	100%, 176°F	HQQV	HQQV	KUHE			
Salicylic acid C ₆ H ₄ (OH)COOH	H	0,1%, 68°F				HQQE	HQQE	KUHE
Silicone oil	E, 3	100%	HQQV	HQQV	KUHV			
Sodium bicarbonate NaHCO ₃	E	10%, 140°F				HQQE	HQQE	KUHE
Sodium chloride (as coolant) NaCl	D, E	30%, <41°F, pH>8	HQQE	HQQE	KUHE			
Sodium hydroxide NaOH	E	20%, 122°F				HQQE	HQQE	KUHE
Sodium hypochlorite NaOCl	F	0,1%, 68°F				HQQV	HQQV	KUHV
Sodium nitrate NaNO ₃	E	10%, 140°F				HQQE	HQQE	KUHE
Sodium phosphate Na ₃ PO ₄	E, H	10%, 140°F				HQQE	HQQE	KUHE
Sodium sulfate Na ₂ SO ₄	E, H	10%, 140°F				HQQE	HQQE	KUHE
Softened water		<248°F				HQQE	HQQE	KUBE
Soybean oil	D, E, 3	100%, 176°F	HQQV	HQQV	KUHV			
Sulfuric acid H ₂ SO ₄	F	1%, 68°F				HQQV	HQQV	KUHV
Sulfurous acid H ₂ SO ₃		1%, 68°F				HQQE	HQQE	KUHE
Swimming pool water (low chloride)		Approx. 2 ppm free chlorine (Cl ₂)	HQQE	HQQE	KUHE			

Pipework connection

For pipework connection, various sets of counter flanges and couplings are available.

Counter flanges for CR(E)

A set consists of two counter flanges, two gaskets, bolts and nuts.

Counter flange	Pump type	Description	Pressure class	Pipework connection	Product number
	TM02 5691 3802	CR 1s CR(E) 1 CR(E) 3 CR(E) 5	Threaded	ANSI 250 lb.	1½" NPT 91 12 22 60
	TM02 5692 3802	CR(E) 10 CR(E) 15 CR(E) 20	Threaded	ANSI 250 lb.	2" NPT 33 50 21
	TM02 5693 + 5694 3802	CR(E) 32	Threaded	ANSI 125 lb.	2½" NPT 55 96 01
			Threaded	ANSI 250 lb.	2½" NPT 34 50 50
	TM02 5695 + 5696 3802	CR(E) 45	Threaded	ANSI 125 lb.	3" NPT 56 96 01
			Threaded	ANSI 250 lb.	3" NPT 91 12 19 52
	TM02 5697 + 5698 3802	CR(E) 64 CR(E) 90	Threaded	ANSI 125 lb.	4" NPT 57 98 01
			Threaded	ANSI 250 lb.	4" NPT 3 60 00 28

Counter flanges for CRN(E)

Counterflanges for CRN(E) pumps are made of stainless steel according to AISI 316.

A set consists of two counter flanges, two gaskets, bolts and nuts.

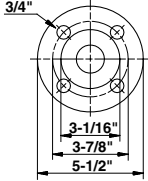
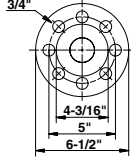
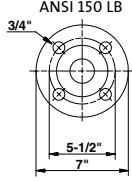
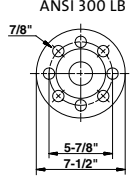
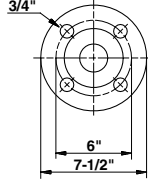
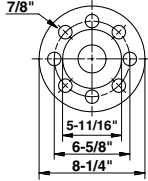
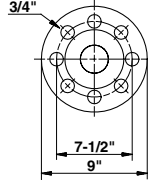
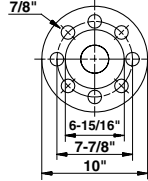
Counter flange	Pump type	Description	Pressure class	Pipework connection	Product number	
	TM02.5691.3802	CRN(E), CRN(E) 1s, 1, 3 and 5	Threaded	ANSI 300 lb.	1½" NPT	91 12 90 13
	TM02.5692.3802	CRN(E), CRN(E) 10, 15, 20	Threaded	ANSI 300 lb.	2" NPT	33 99 19
	TM02.5693 + 5694.3802	CRN(E) 32	Threaded	ANSI 150 lb.	2½" NPT	91 12 19 51
			Threaded	ANSI 300 lb.	2½" NPT	01 D0 01 38
	TM02.5695 + 5696.3802	CRN(E) 45	Threaded	ANSI 150 lb.	3" NPT	91 12 19 53
			Threaded	ANSI 300 lb.	3" NPT	91 12 19 54
	TM02.5697 + 5698.3802	CRN(E) 64 CRN(E) 90	Threaded	ANSI 150 lb.	4" NPT	01 D0 01 48
			Threaded	ANSI 300 lb.	4" NPT	91 12 19 55

PJE couplings for CRN(E)

Couplings for CRN(E) pumps are made of stainless steel according to AISI 316.

A set consists of two couplings, two gaskets, two pipe stub and bolts and nuts.

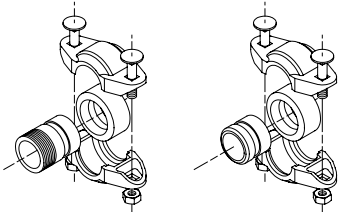
Couplings	Pump type	Pipe stub	Rated pressure	Pipework connection	Rubber parts	Number of coupling sets needed	Product number
	CRI(E), CRN(E) 1s, 1, 3 and 5	Threaded	1160 psi	1¼" NPT	EPDM	1	4 01 30 10
					FKM	1	01 D0 01 18
	CRI(E) CRN(E) 10, 15 and 20	Threaded	1015 psi	2" NPT	EPDM	1	33 13 01
					FKM	1	01 D0 01 28

FlexiClamp base connections

All sets comprise the necessary number of bolts and nuts as well as a gasket/O-ring.

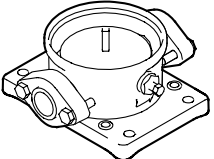
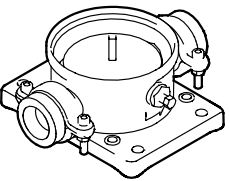
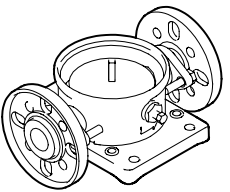
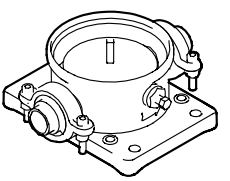
Base connections	Pump type	Connection	Pipework connection	Rubber parts	Product number
	CRI(E), CRN(E) 1s, 1, 3 and 5	Oval (cast iron)	1" NPT	Klingsil	96 46 84 91
			1¼" NPT	Klingsil	96 47 07 81
			1" NPT	Klingsil	96 48 08 50
			1¼" NPT	Klingsil	96 48 08 51
	CRI(E), CRN(E) 1s, 1, 3 and 5	Union ext. threaded	2" NPT	EPDM	96 48 08 52
				FKM	96 48 08 53
	CRI(E), CRN(E) 1s, 1, 3 and 5	ANSI (FGJ) (stainless steel)	1¼" NPT	EPDM	96 48 08 58
				FKM	96 48 08 59
	CRI(E), CRN(E) 1s, 1, 3 and 5	Clamp, threaded pipe stub	1" NPT	EPDM	96 48 08 54
				FKM	96 48 08 55
			1¼" NPT	EPDM	96 48 08 56
				FKM	96 48 08 57

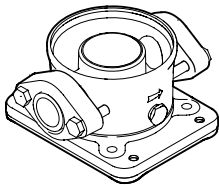
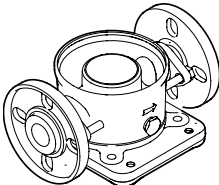
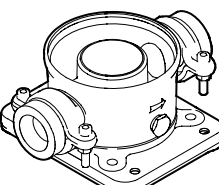
Base connections	Pump type	Connection	Pipework connection	Rubber parts	Product number
	TM02 7237 2803 CRI(E), CRN(E) 10, 15 and 20	Oval (cast iron)	2" NPT	Klingersil	96 49 88 38
		Oval (stainless steel)	2" NPT	Klingersil	96 49 88 39
	TM02 7238 2803 CRI(E), CRN(E) 10, 15 and 20	ANSI (FGJ) (stainless steel)	2" NPT	EPDM	96 51 14 02
				FKM	96 51 14 03
	TM02 7239 2803 CRI(E), CRN(E) 10, 15 and 20	Clamp, threaded pipe stub	1½" NPT	EPDM	96 50 02 71
				FKM	96 50 02 72
			2" NPT	EPDM	96 50 02 73
				FKM	96 50 02 74
			2½" NPT	EPDM	96 50 86 02
				FKM	96 50 86 03

Potentiometer for CRE, CRIE, CRNE

Potentiometer for setpoint setting and start/stop of the CRE, CRIE, CRNE pump.

Product	Product number
External potentiometer with cabinet for wall mounting	62 54 68

G10-LON interface for CRE, CRIE, CRNE

The G10-LON interface is used in connection with data transmission between a Locally Operating Network (LON) and electronically controlled Grundfos pumps applying the Grundfos bus-protocol GENibus.

Product	Product number
G10-LON interface	00 60 57 26

Remote control, R100

R100 is used for wireless communication with the CRE, CRIE, CRNE pump. The communication takes place by means of infrared light.

Product	Product number
R100	62 53 33

LiqTec for CR(E), CRI(E) and CRN(E)

A dry-running protection device. The Grundfos LiqTec stops the pump immediately

- if there is no liquid in the pump (dry-running)
- if the liquid temperature exceeds 266°F ±8°F.

When connected to the PTC sensors in the motor, the LiqTec also protects the motor against overheating.

LiqTec is prepared for DIN rail mounting in control cabinet.

Enclosure class: IP X0.

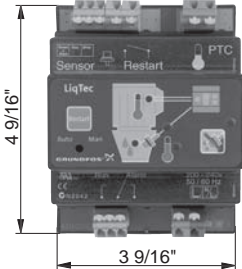
LiqTec dry-running protection	Pump type	Voltage [V]	LiqTec	Sensor ½"	Cable 16.4 ft	Extension cable 49.2 ft	Product number
 <p>4 9/16"</p> <p>3 9/16"</p> <p>TM03 2109 3705</p>	<p>CR(E) CRI(E) CRN(E)</p>	200-240	●	●	●	-	96556429
		80-130	●	●	●	-	96556430
		-	-	-	-	●	96443676

Sensors for CRE, CRIE, CRNE

Accessory	Measuring range	Product number
Pressure sensor • Connection: 1/4" NPT	0-200 psi	91120777
	0-58 psi (0-4 bar)	96026029
	0-87 psi (0-6 bar)	96026030
	0-145 psi (0-10 bar)	96026031
	0-232 psi (0-16 bar)	96026032
	0-362 psi (0-25 bar)	96026033

Gauges for CRE, CRIE, CRNE

Accessory	Measuring range	Product number	
Liquid filled pressure gauge • AISI 304/Copper	30" Hg - 30 psi	91123566	
	0-60 psi	00ID8562	
	0-100 psi	00ID8563	
	0-160 psi	00ID8564	
	0-200 psi	00ID8565	
	0-300 psi	00ID8566	
	0-400 psi	00ID8567	
	0-600 psi	00ID8568	
	Liquid filled pressure gauge • AISI 316	30" Hg - 30 psi	91130835
		0-60 psi	00ID8569
0-100 psi		00ID8570	
0-160 psi		00ID8571	
0-200 psi		00ID8572	
0-300 psi		00ID8573	
0-400 psi		00ID8574	
0-600 psi		00ID8575	
	0-200 psi	00ID8576	

Lists of variants - on request

Although the Grundfos CR(E), CRI(E), CRN(E) product range offers a number of pumps for different applications, customers require specific pump solutions to satisfy their needs.

Below please find the range of options available for customizing the CR(E) pumps to meet the customers' demands. Contact Grundfos for further information or for requests other than the ones mentioned below.

Motors

Variant	Description
Explosion proof motors	For operation in hazardous atmospheres, explosion-proof or dust-ignition-proof motors may be required.
Motors with anti-condensation heating unit	For operation in humid environments motors with built-in anti-condensation heating may be required.
Energy efficient motors	Grundfos offers motors from 1 to 60 Hp with energy efficient EPAct/NRC class and Premium efficiency class.
Different motor brand	If technically possible, Grundfos can fit the pump with a motor of a brand other than the standard. This will normally increase the time of delivery. Alternatively, the pump can be supplied without a motor (motor thrust rating must be checked).
Oversized motor	Ambient temperatures above 104°F or installation at altitudes of more than 3280 ft above sea level require the use of an oversized motor (i.e. derating).
4-pole motors	Grundfos offers standard motors fitted with 4-poles.

Connections and other variants

Variant	Description
Pipe connections	In addition to the wide range of standard flange connections, a 232 Psi DIN standard clamping flange is available. Customized flanges are available according to specifications.
TriClamp connections	TriClamp connections are of a hygienic design with a sanitary coupling for use in the pharmaceutical and food industry.
Electropolished pumps	To substantially reduce the risk of corrosion of the materials. For use in the pharmaceutical/food industry.

Shaft seals

Variant	Description
Shaft seal with FFKM O-ring material	Shaft seals with FFKM or FXM o-ring material are recommended for applications where the pumped liquid may damage the standard O-ring material.
Seal with flush, quench seal	Recommended for applications involving crystallizing, hardening or sticky liquids.
Cool-Top® shaft seal system	Recommended for applications involving extremely high temperatures. No conventional mechanical shaft seal can withstand liquid temperatures of up to 356°F for any length of time. For that type of application, Grundfos' unique air-cooled shaft seal system is recommended. In order to ensure a low liquid temperature around the standard shaft seal, the pump is fitted with a special air-cooled shaft seal chamber. No separate cooling is required.
Double shaft seal with pressure chamber	Recommended for applications involving poisonous or explosive liquids. Protects the surrounding environment and the people working in the vicinity of the pump. Consists of two seals mounted in a "back-to-back" arrangement inside a separate pressure seal chamber. As the pressure in the chamber is higher than the pump pressure, leakage is prevented. A dosing pump or a special pressure-intensifier generates the seal chamber pressure.
CR MAGdrive	Magnetically driven pumps for industrial applications. Key applications are industrial processes involving the handling of aggressive, environmental, dangerous or volatile liquids, e.g. organic compounds, solvents, etc.

Pumps

Variant	Description
Horizontally mounted pump	For safety or height reasons, certain applications, for instance on ships, require the pump to be mounted in the horizontal position. For easy installation the pump is equipped with brackets that support motor and pump.
Low-temperature pump down to -40°F	Exposed to temperatures down to -40°F, coolant pumps may require neck-rings with a different diameter in order to prevent impeller drag.
High-speed pump up to 681 psi	For high-pressure applications, a unique pump capable of generating up to 681 psi pressure is available. The pump is equipped with a high-speed motor, type MLE. The direction of rotation is the opposite of that of standard pumps, and the chamber stack is turned upside-down, as a result of which the pumped liquid flows in the opposite direction.
High-pressure pump up to 696 psi	For high-pressure applications, a unique double pump system capable of generating up to 696 psi pressure is available.
Low-NPSH pump (improved suction)	Recommended for boiler-feed applications where cavitation may occur due to poor inlet conditions. The bearing flange is suitable for applications where the inlet pressure is higher than the maximum pressure recommended. The bearing flange increases the life of motor bearings. (Recommended for standard motors).
Pump with bearing flange	
Belt-driven pumps	Belt-driven pumps designed to operate in places with limited space or where no electrical power is available.
Pumps for pharmaceutical and biotechnological applications	CRN(E) pumps designed for applications requiring the sterilization and CIP capability of pipes, valves and pumps. (CIP = Cleaning-In-Place).

Submittal data sheet

CR(E), CRI(E), CRN(E)

Vertical Multistage Centrifugal Pumps

Company name: _____
 Prepared by: _____
 Phone number: () - _____
 Fax number: () - _____
 Date: _____ Page 1 of: _____
 Quote number: _____

Client Information

Project title: _____ Client name: _____
 Reference number: _____ Client number: _____
 Client contact: _____ Client phone no: () - _____

Location Information

For: _____ Unit: _____
 Site: _____ Service: _____
 Address: _____ City: _____ State: _____ Zip Code: _____

Application Information

Operating Conditions				Pumped Fluid			
	Max.	Norm.	Min.		Rated	Max.	Norm.
Capacity (gpm)	_____	_____	_____	Fluid type:	_____		
Suction Pressure (psig)	_____			Fluid Temperature (°F)	_____		
Discharge Pressure (psig)	_____			at designated temperature	_____		
Differential Head (ft)	_____			Specific Gravity	_____		
Hydraulic Power (hp)	_____			Vapor Pressure (psia)	_____		
at designated capacity	_____			Viscosity (cp)	_____		
NPSH Available (ft)	_____			Fluid ph:	_____	Chlorides (ppm):	_____
Service				Hazardous:	_____	Corrosion/Errosion	_____
Continuous	_____			Flammable:	_____	caused by:	_____
Intermittent (starts/day):	_____			Other:	_____		_____

Pump Information

Model Information from Type Key and Codes: _____ ----> (Example: CR 5-10 A-FGJ-A-E-HQQE)
 Quantity Required: _____
 Minimum required flow: _____ NPSH required at duty point: _____
Product Guide additional information pages
 Materials page number: _____ Performance curve page number: _____
 Technical data page number: _____ Motor data page number: _____

Motor Information

HP: _____ Phase: _____ Voltage: _____ Enclosure: _____

Custom-built pump information (optional):

Additional Information

Quotation text

CR(E), CRI(E), CRN(E)

Vertical, non-self-priming, multistage, in-line, centrifugal pump for installation in pipe systems and mounting on a foundation.

The pump has the following characteristics:

- impellers and intermediate chambers are made of AISI _____ Stainless steel
- Pump head and base are made of _____
- Power transmission is via cast iron split coupling.
- pipework connections is via _____

The motor is a _____-phase AC motor.

Technical

Rated flow: _____ GPM
Rated head: _____ Feet
Minimum liquid temperature: _____ °F
Maximum liquid temperature: _____ °F
Type of shaft seal: _____

Materials

Material, pump housing: _____
Material, shaft: AISI _____ Stainless Steel
Material, impeller: AISI _____ Stainless Steel
Material, sleeve: AISI _____ Stainless Steel
Material, seal metal: AISI _____ Stainless Steel
- seal face: _____
- seal face: _____
- seal elastomer: _____

Installation

Maximum ambient temperature: _____ °F
Max. pressure at stated temp.: _____ PSI/°F
Standard, pipe connection: _____
Size, pipe connection: _____
Rated pressure, pipe connection: _____ PSI
Frame size for motor: _____ NEMA

Electrical data

Motor type: _____
Rated power (P2): _____ HP
Frequency: _____ Hz
Rated voltage: _____ V
Rated current: _____ A
Service factor: _____
Starting current: _____ A
Rated speed: _____ RPM
Full load motor efficiency: _____ %
Insulation class: _____

Additional

Gross weight: _____ Lbs.
Shipping volume: _____
Model: _____

Further product documentation

Sources of product documentation

In addition to the printed data booklet, Grundfos offers the following sources of product documentation.

- WinCAPS
- WebCAPS.

WinCAPS®

WinCAPS is a **Windows-based Computer-Aided Product Selection** program containing information on more than 90,000 Grundfos products.

Available on CD-ROM in more than 15 languages, WinCAPS offers

- detailed technical information
- selection of the optimum pump solution
- dimensional drawings of each pump
- detailed service documentation
- installation and operating instructions
- wiring diagrams of each pump.



Fig. 29 WinCAPS CD-ROM

cd-wincaps

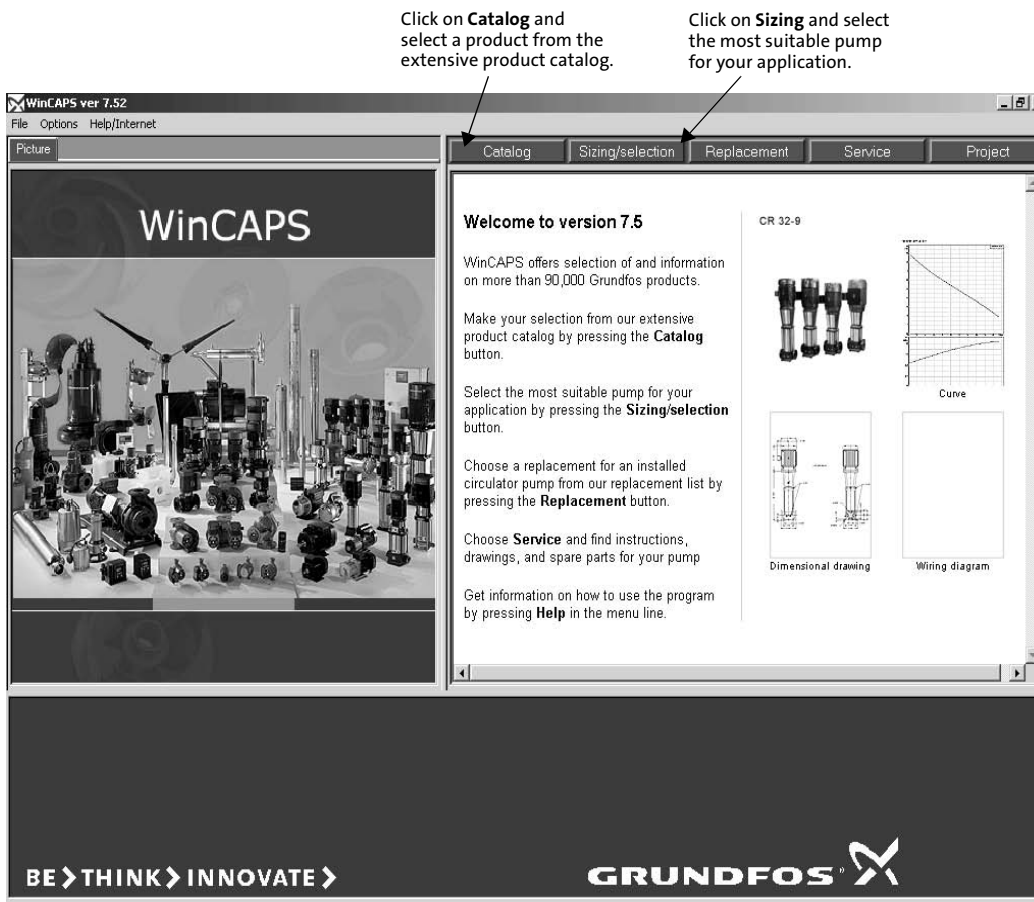

Fig. 30 WinCAPS

WinCAPS_US

Further product documentation

WebCAPS®

WebCAPS is a **Web**-based **Computer Aided-Product Selection** program and a web-version of WinCAPS.

Available on Grundfos' homepage, www.grundfos.com, WebCAPS offers

- detailed technical information
- dimensional drawings of each pump
- wiring diagrams of each pump.

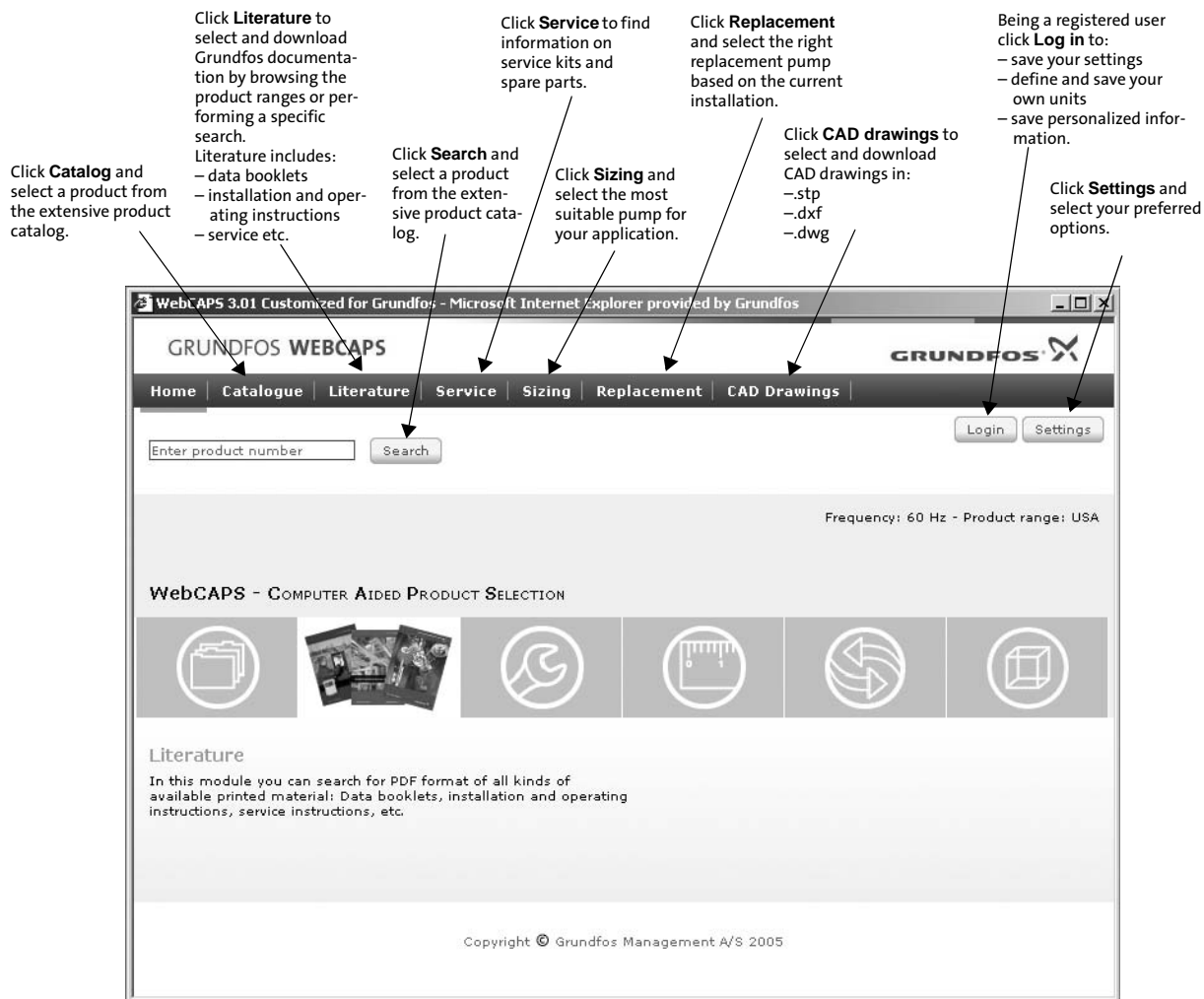

Fig. 31 WebCAPS

WebCAPS_US

L-CR-PG-001 10/05	US
Repl.: L-CR-PG-001 11/04	

Subject to alterations.