

# G&L Series SSV

**TECHNICAL  
MANUAL**

**SSV Series  
Vertical  
Multi-Stage  
Pumps**

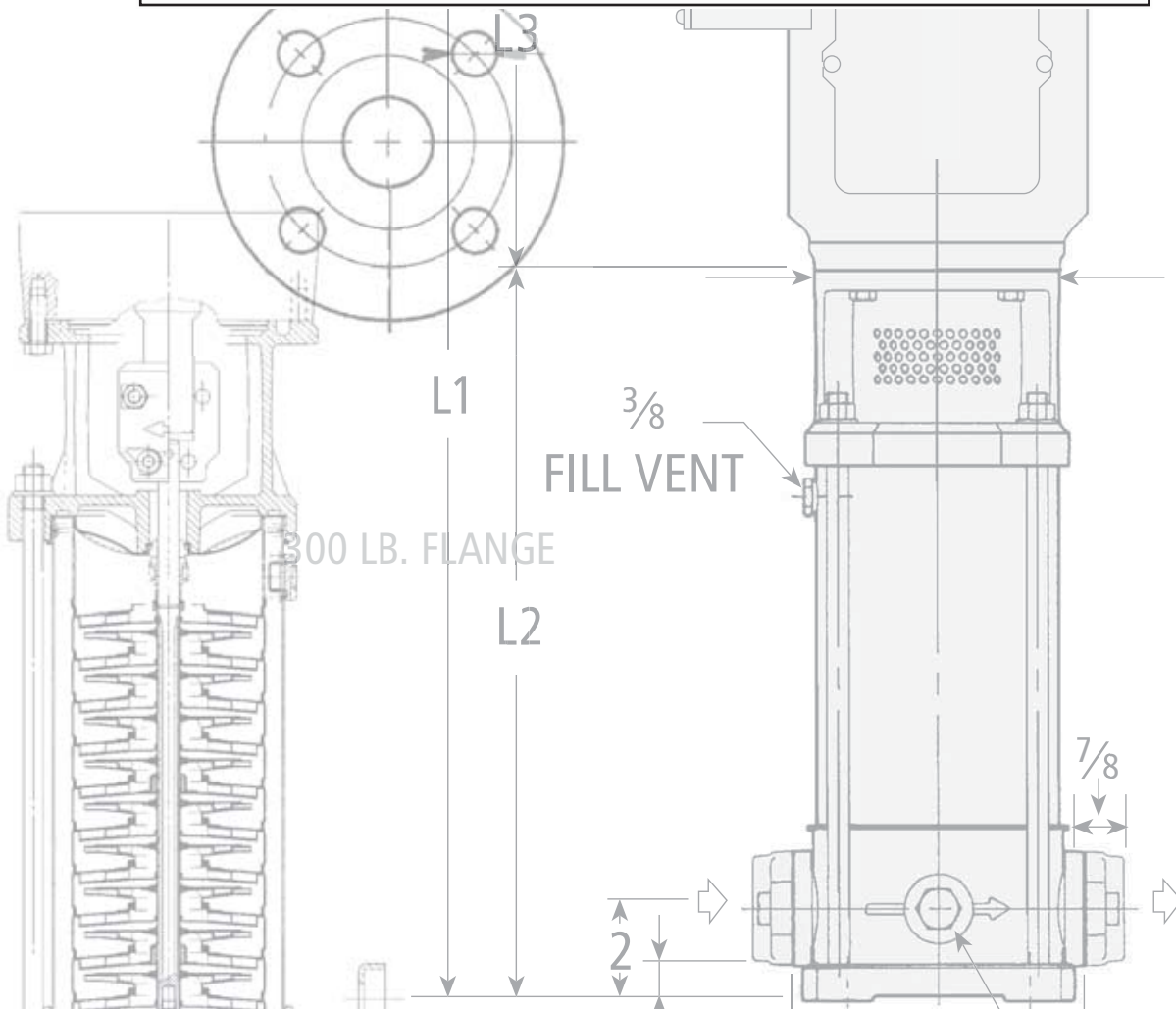
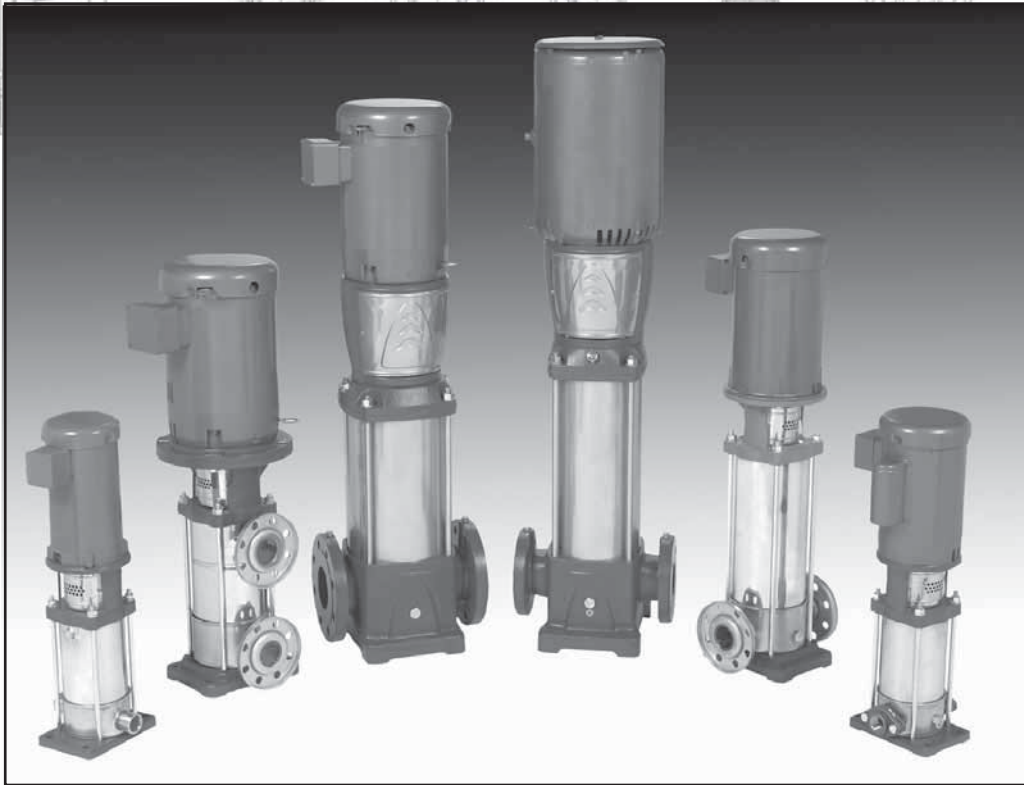

---

## Contents

---

Coverage Curves . . . . .	1
General Market Specifications . . . . .	2
Characteristics of 1, 2, 3 and 4SV Series . . . . .	3
Characteristics of 33, 46, 66 and 92SV Series . . . . .	3
General Characteristics . . . . .	4
Typical Applications of SV Pumps . . . . .	5
SSV Nomenclature . . . . .	6-7
1, 2, 3 and 4SV Series Pump Cross Section and Main Components. . . . .	8-9
33, 46, 66 and 92SV Series Pump Cross Section and Main Components. . . . .	10-11
SV Mechanical Seals. . . . .	12
Maximum Allowable Working Pressure Charts . . . . .	13
Motor Data . . . . .	14-17
3500 RPM Curves, Dimensions and Weights . . . . .	18-33
2900 RPM Curves, Dimensions and Weights . . . . .	34-49
Round Counterflanges . . . . .	50
Victaulic Accessories . . . . .	50
Horizontal Mounting Options . . . . .	51-52
Table of Hydraulic Performances at 3500 RPM . . . . .	53-56
Table of Hydraulic Performances at 1750 RPM . . . . .	57-60
Technical Appendix. . . . .	61-63

# SSV Coverage Curve

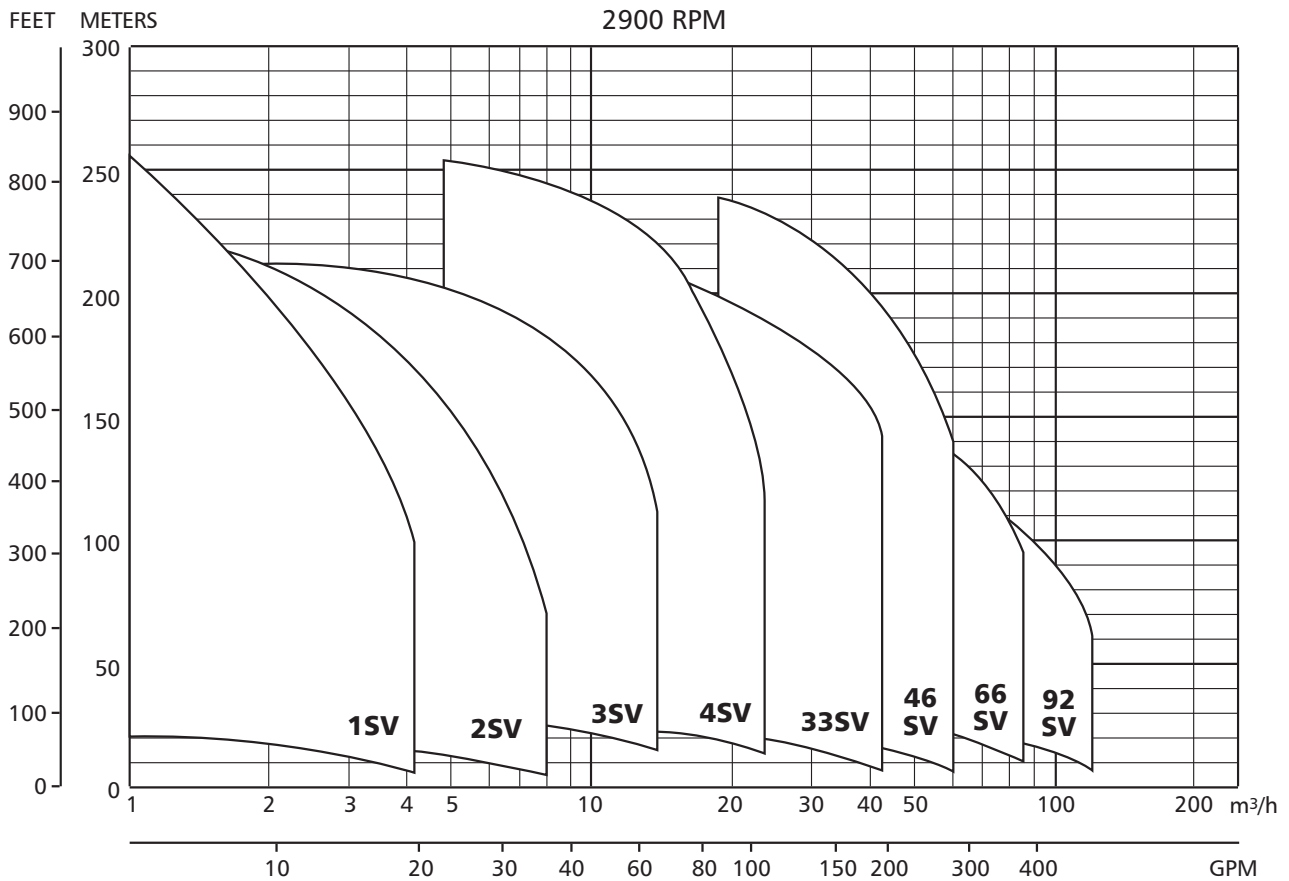
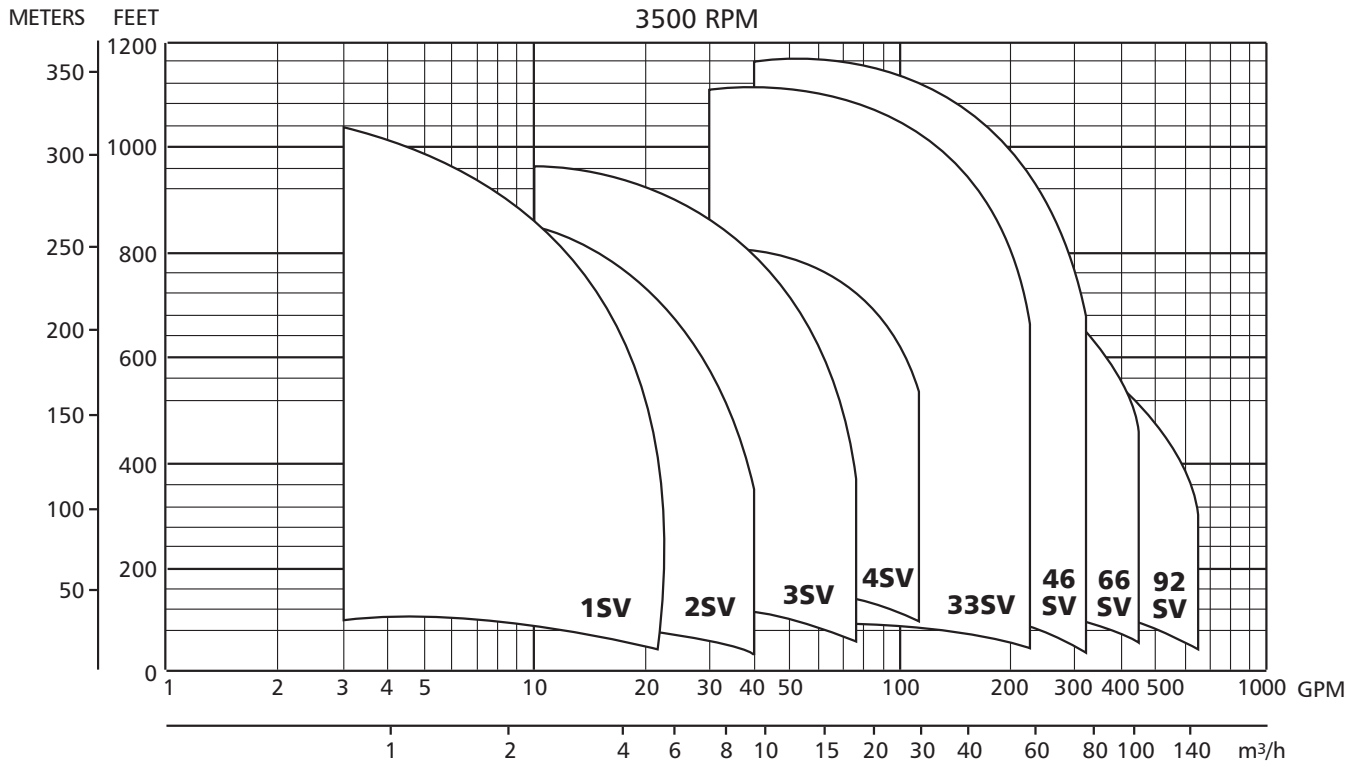

---

## SSV General Market Specifications

---

MUNICIPAL, AGRICULTURAL, LIGHT INDUSTRY, WATER TREATMENT, HEATING AND AIR CONDITIONING

### Applications

- Handling of water, free of suspended solids, in the municipal, industrial and agricultural markets
- Pressure boosting and water supply systems
- Fire fighting jockey pumps
- Irrigation systems
- Wash systems
- Water treatment plants: reverse osmosis
- Handling of moderately aggressive liquids, demineralized water, water and glycol, etc.
- Circulation of hot and cold water for heating, cooling and conditioning systems
- Boiler feed

### Specifications

#### PUMP

The SSV pump is a non-self priming vertical multistage pump coupled to a standard motor.

The liquid end, located between the upper cover and the pump casing, is held in place by tie rods. The pump casing is available with different configurations and connection types.

- Delivery: up to 600 GPM
- Head: up to 1200 feet
- Temperature of pumped liquid:  
-20°F to 250°F (-30°C to 120°C) standard version
- Maximum operating pressure
  - with oval flanges: 230 PSI (15 bar)
  - with round flanges or Victaulic: 360 PSI (25 bar)
  - SV33, 46: 230, 360 or 575 PSI (16, 25 or 40 bar)\*
  - SV 66, 92: 230 or 360 PSI (16 or 25 bar)\*
- Direction of rotation: clockwise looking at the pump from the top down (marked with an arrow on the adapter and on the coupling).

#### MOTOR

- Standard NEMA TC Frame motors in open drip proof or totally enclosed fan cooled.
- 3500 RPM nominal
- Standard voltage:
  - Single phase version: 115-208/230 V, 60 Hz up to 3 HP or 208-230 V for 5 HP
  - Three phase version, 2 pole: 208-230/460 V, 60 Hz up to 75 HP

\* Based on pump staging

---

## SSV Characteristics

---

### 1SV, 2SV, 3SV, 4SV Series

- Vertical multistage centrifugal pump. All metal parts in contact with the pumped liquid are made of stainless steel.
- The following versions are available:
  - B – ANSI flanges, in-line delivery and suction ports, AISI 304
  - A – Oval flanges (NPT), in-line delivery and suction ports, AISI 304
  - C – ANSI flanges, delivery port above the suction port, with four adjustable positions, AISI 304
  - D – ANSI flanges, in-line delivery and suction ports, AISI 316
  - VIC – Victaulic couplings, in-line delivery and suction ports, AISI 316
- Reduced axial thrusts enable the use of standard NEMA TC motors that are easily found in the market
- Seal housing chamber designed to prevent the accumulation of air in the critical area next to the mechanical seal
- Mechanical seal according to EN 12756 (ex DIN 24960) and ISO 3069
- Versions with ANSI flanges that can be coupled to ANSI raised face counter-flanges
- Threaded oval counter-flanges made of stainless steel are standard supply for the A versions
- Easy maintenance. No special tools required for assembly or disassembly
- Standard version for temperatures ranging from: -20°F to 250°F (30°C to 120°C)

---

### 33SV, 46SV, 66SV, 92SV Series

- Vertical multistage centrifugal pump with impellers, diffusers and outer sleeve made entirely of stainless steel, and with pump casing and motor adapter made of cast iron in the standard version
- D version made entirely of AISI 316 stainless steel
- High heads and capacities four sizes: 33SV, 46SV, 66SV, 92SV (replacing the previous models 5SV and 6SV)
- Re-designed liquid end provides improved efficiency and energy savings
- Innovative axial load compensation system on pumps with higher head. This ensures reduced axial thrusts and enables the use of standard NEMA TC motors that are easily found in the market.
- Balanced mechanical seal according to EN 12756 (ex DIN 24960) and ISO 3069, which can be replaced without removing the motor from the pump
- Seal housing chamber designed to prevent the accumulation of air in the critical area next to the mechanical seal
- Standard version for temperature ranging from: -20°F to 250°F (-30°C to 120°C)
- Pump body fitted with taps for installing pressure gauges on both suction and delivery flanges
- In-line ports with ANSI flanges that can be coupled to counter-flanges, in compliance with ANSI raised face.
- Mechanical sturdiness and easy maintenance. No special tools required for assembly or disassembly.

---

### Optional Features

- Horizontal version.
- Special voltages, 50 Hz frequency.
- Special materials for the mechanical seal, gaskets and elastomers,
- “DPS” sets consisting of two “SV” electric pumps made of AISI 316, connected in series to obtain a total head equal to the sum of the single heads of the two electric pumps.
- Tropicalized motors.
- Premium E and explosion proof motors.
- 1750 RPM, 4 pole motors.

## General Characteristics

### 2-pole

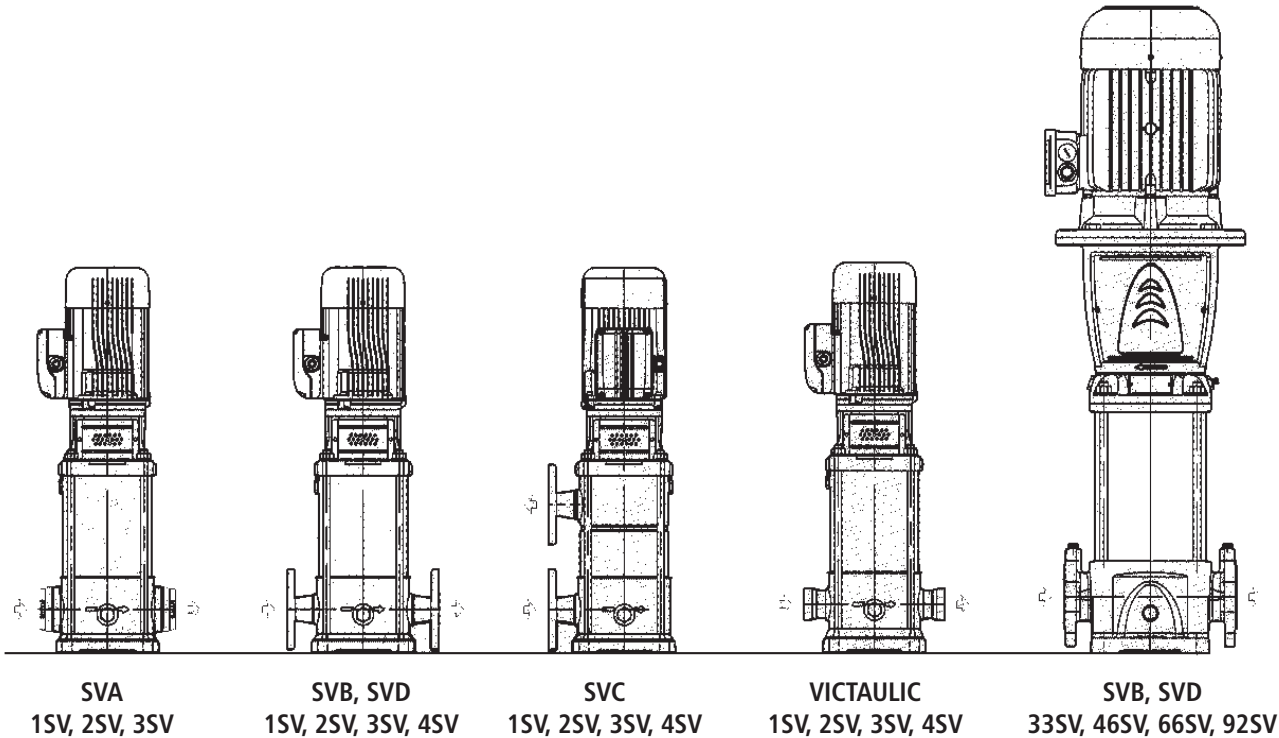

SSV Product Range	1SV	2SV	3SV	4SV	33SV	46SV	66SV	92SV
Nominal Flow (GPM)	15	30	60	85	150	220	350	450
Flow Range (GPM)	2 – 22	6 – 40	11 – 75	17 – 110	30 – 195	45 – 285	70 – 420	90 – 580
Max. Head (Ft)	1100	945	1005	930	1125	1210	850	715
Max. Working Pressure (PSI) <sup>②</sup>	360 PSIG <sup>①</sup>				360 / 580 PSIG			
Temperature Range	-20°F to 250°F (-30°C to -121°C)							
Motor Power (HP)	½ – 5 HP	¾ – 5 HP	2 – 15 HP	5 – 20 HP	3 – 60 HP	7½ – 75 HP	10 – 75 HP	15 – 75 HP
Max. Pump Efficiency	44%	58%	64%	67%	76%	78%	78%	80%
Material of Construction								
SVA	AISI 304SS				–	–	–	–
SVB	AISI 304SS				Cast Iron / AISI 316L			
SVC	AISI 304SS				–	–	–	–
SVD	AISI 316LSS				Cast Stainless Steel / AISI 316L			
Connection Sizes								
SVA – Oval NPT	1" NPT (female)	1¼" NPT (female)	1½" NPT (female)	–	–	–	–	–
SVB – Round ANSI Size/Class	1¼" 300#	1¼" 300#	2" 300#	2" 300#	2½" 125/250#	3" 1325/250#	4" 125/250#	4" 125/250#
SVC – Top/Bottom Round ANSI – Size/Class	1¼" 300#	1¼" 300#	2" 300#	2" 300#	–	–	–	–
SVD – Round ANSI Size/Class	1¼" 300#	1¼" 300#	2" 300#	2" 300#	2½" 150/300#	3" 150/300#	4" 150/200#	4" 150/300#
Optional Connections (on request)								
Victaulic (PJE)	1¼" (Victaulic)	1¼" (Victaulic)	2" (Victaulic)	2" (Victaulic)	–	–	–	–

<sup>①</sup> Some staging may have MAWP of 580 psi (40 bar).

<sup>②</sup> See pages 53-60 for specific details.

## Typical Applications of SSV Series Multi-Stage Pumps

### Water Supply and Pressure Boosting

- Pressure boosting in buildings, hotels, residential complexes
- Pressure booster stations, supply of water networks
- Booster packages

### Water Treatment

- Ultrafiltration systems
- Reverse osmosis systems
- Water softeners and de-mineralization
- Distillation systems
- Filtration

### Light Industry

- Washing and cleaning plants (washing and degreasing of mechanical parts, car and truck wash tunnels, washing of electronic industry circuits)
- Commercial washers
- Firefighting system pumps

### Irrigation and Agriculture

- Greenhouses
- Humidifiers
- Sprinkler irrigation

### Heating, Ventilation and Air Conditioning (HVAC)

- Cooling towers and systems
- Temperature control systems
- Refrigerators
- Induction heating
- Heat exchangers
- Boilers
- Water recirculation and heating

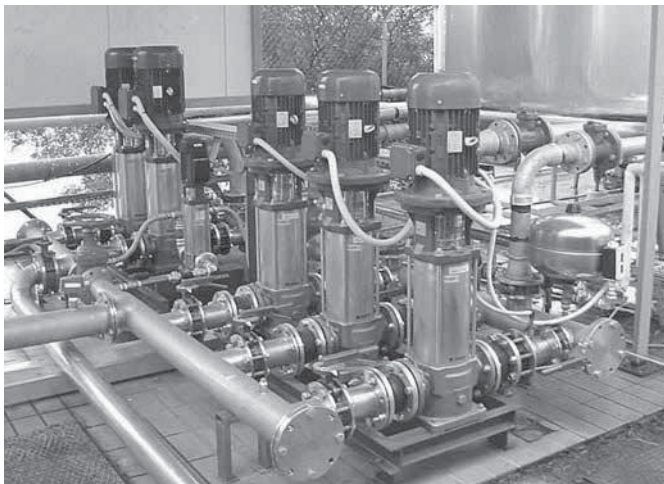
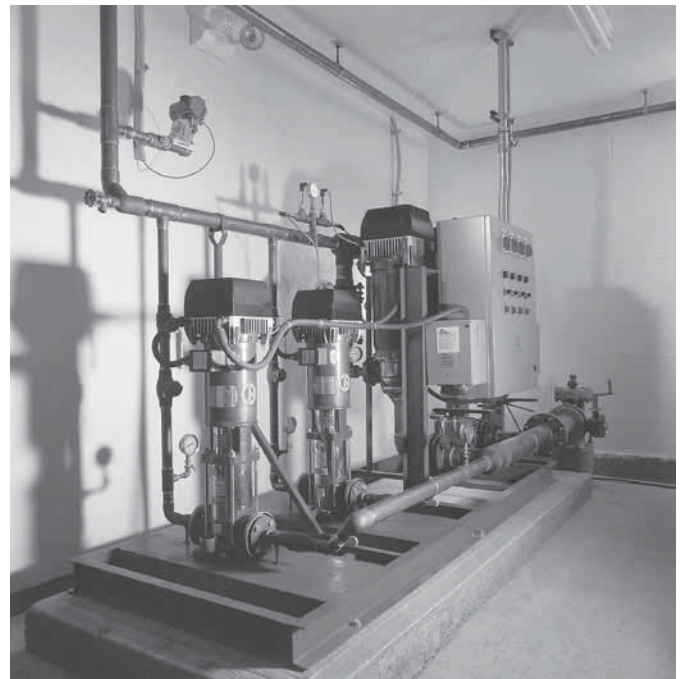
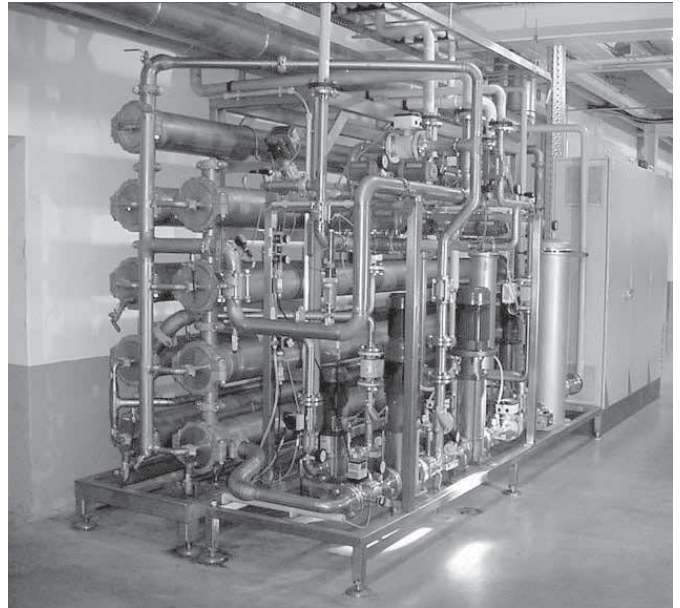

## SSV Product Line Numbering System for 1 – 4SV

The various versions of the SSV line are identified by a product code number on the pump label. This number is also the catalog number for the pump. The meaning of each digit in the product code number is shown below.

**Note:** Not all combinations are possible. Consult your G&L distributor.

### Example Product Code

2 SV A 1 D 2 B 1 H

**Options:** H = Horizontal mount, **refer to back cover**  
VIC = Victaulic connections (**1SVB/D – 4SVB/D only**)

### Mechanical Seal Options:

Code No.	Rotary	Stationary	Elastomer	Reference Application
0	High Temp. Carbon	Silicon Carbide Graphite Filled	Viton	General Service
4	Silicon Carbide Graphite Filled			Abrasive
6	High Temp. Carbon		EPR	Boiler Feed

### Number of Stages:

B = 2 D = 4 F = 6 H = 8 K = 10 M = 12 P = 14 R = 16 V = 20 Z = 24  
C = 3 E = 5 G = 7 J = 9 L = 11 N = 13 Q = 15 T = 18 X = 22

### Driver:

(50 Hz, no single phase number 0, 1, 4)  
1 = 1 PH, ODP 3 = 575V, ODP 5 = 3 PH, TEFC 7 = 3 PH, XP 9 = 3 PH, TEFC with premium efficiency  
2 = 3 PH, ODP 4 = 1 PH, TEFC 6 = 575V, TEFC 8 = 575V, XP 0 = 1 PH, XP

### HP Rating:

C = ½ E = 1 G = 2 J = 5 L = 10 N = 20  
D = ¾ F = 1½ H = 3 K = 7½ M = 15 P = 25

### Hertz/RPM:

1 = 60 Hz, 3500 RPM 3 = 60 Hz, 3500 RPM, 380 V 5 = 60 Hz, 3500 RPM, 220-380 V, D.O.L.  
2 = 50 Hz, 2900 RPM, 190-380 V, (50 Hz motor) 4 = 50 Hz, 2900 RPM, 460 V 6 = 60 Hz, 3500 RPM, 380 V, Y-DELTA  
7 = 60 Hz, 1750 RPM, 208-230, 460 V

### Material and Suction/Discharge:

A = 304 stainless steel, in-line NPT threaded oval flange connections (1, 2, 3 only)  
B = 304 stainless steel, in-line ANSI flange (1, 2, 3, 4SV)  
C = 304 stainless steel, top/bottom ANSI flange connections  
D = 316 stainless steel, in-line ANSI flange

### Product Line:

Stainless Vertical

### Nominal Flow:

1 = 15 GPM 2 = 28 GPM 3 = 55 GPM  
4 = 86 GPM

## Rating Plate 1, 2, 3 and 4SV

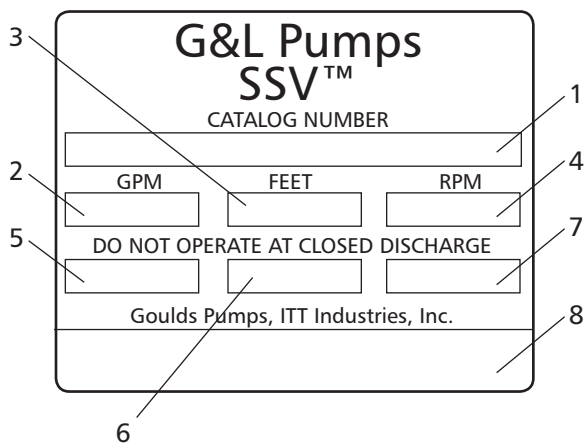

1	Goulds Catalog Number
2	Capacity Range
3	TDH Range
4	Rated Speed
5	Rated Horsepower
6	Maximum Operating Pressure
7	Maximum Operating Temperature
8	Pump Serial Number

# SSV Product Line

## Numbering System for 33 – 92SV

The various versions of the SSV line are identified by a product code number on the pump label. This number is also the catalog number for the pump. The meaning of each digit in the product code number is shown below.

**Note:** Not all combinations are possible. Consult your G&L distributor.

### Example Product Code

33 SV B G 1 2 R 6 T A H

#### Pump Options (optional – to be listed in sequential order)

H = Horizontal mounting  
Q = 1.0 Service Factor Version (AQ)

D = High Pressure Pump (40 Bar)<sup>①</sup>  
T = Alternative Motor Frame

#### Seal Options:

	Code No.	Rotary	Stationary	Elastomers
Mechanical Seal	A	Silicon Carbide	Carbon	Viton
	B			EPR
	C		Silicon Carbide	Viton
	D			EPR
Cartridge Seal	L	Silicon Carbide	Carbon	Viton
	P	Graphite Filled	Silicon Carbide	EPR

– Metal parts on all seals are 316SS.  
– Silicon carbide is graphite filled.

#### Motor Enclosure:

D = ODP  
X = Explosion Proof

T = TEFC  
P = TEFC Premium Effy

#### Motor Voltage:

1 = 115/230  
5 = 575

2 = 230  
6 = 208-230/460

3 = 230/460  
7 = 200

4 = 460  
8 = 190/380

#### HP Rating:

G = 2 HP  
H = 3 HP  
J = 5 HP  
K = 7½ HP  
L = 10 HP

M = 15 HP  
N = 20 HP  
P = 25 HP  
Q = 30 HP  
R = 40 HP

S = 50 HP  
T = 60 HP  
U = 75 HP

#### Motor Hertz/Speed/Phase:

1 = 60 Hz/3500/1  
5 = 50 Hz/2900/1  
9 = 60 Hz/Variable/3

2 = 60 Hz/3500/3  
6 = 50 Hz/2900/3

3 = 60 Hz/1750/1  
7 = 50 Hz/1450/1

4 = 60 Hz/1750/3  
8 = 50 Hz/1450/3

#### Number of Reduced Impellers (can be 0, 1, 2) \*

#### Total Bowls/Stages:

A = 1  
B = 2  
C = 3  
D = 4

E = 5  
F = 6  
G = 7  
H = 8

J = 9  
K = 10

#### Flange Orientation:

B = Cast Iron/316 stainless steel, in-line ANSI flange  
D = 316 stainless steel, in-line ANSI flange

#### Product Line:

Stainless Vertical Vertical

#### Nominal Flow:

33 = 150 GPM  
46 = 225 GPM

66 = 350 GPM  
92 = 450 GPM

**\* NOTE:** Indicates number of reduced diameter impellers in the total staging.  
(2 would indicate 2 reduced diameter impellers)

<sup>①</sup> Alternative motor frame will be next larger frame size than what is standard.

**Base Models: 1SV, 2SV, 3SV  
and 4SV Major Components**

**Series SVA**

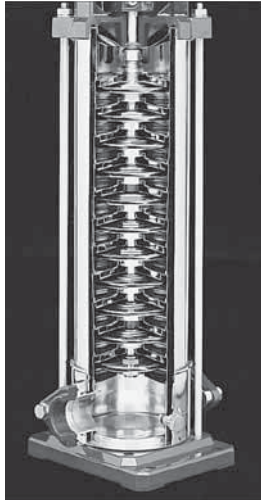

**In-line NPT connections**

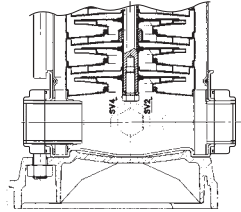

**Series SVC**

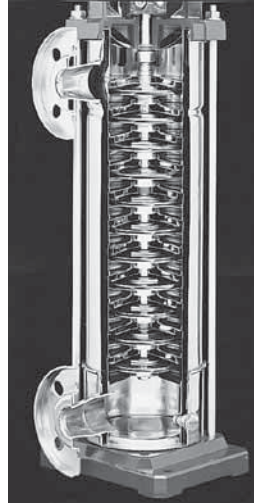

**Top and bottom suction/discharge design**

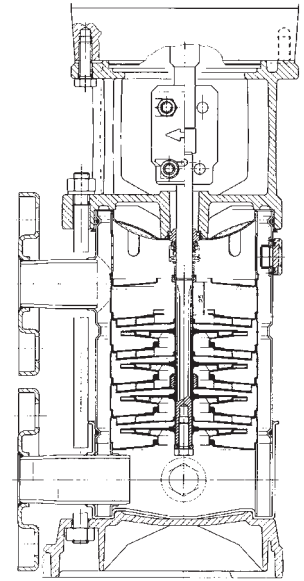

**Series SVB or SVD**

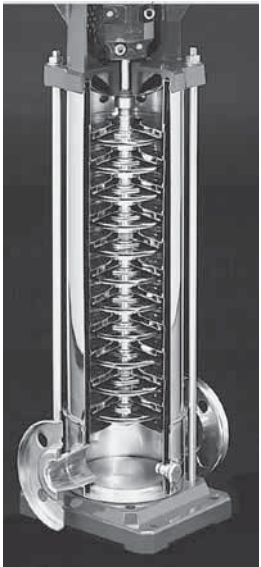

**In-line ANSI  
flange connections**

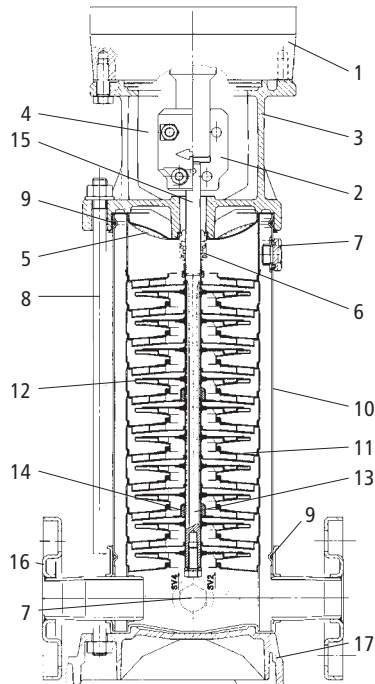

**Base Models: 1SV, 2SV, 3SV  
and 4SV Major Components**

No.	Description	SVA, SVB, SVC (1, 2, 3 and 4 SSV Sizes)			SVD (1, 2, 3 and 4 SSV Sizes)		
		Material	ASTM	DIN	Material	ASTM	DIN
1	NEMA Vertical Motor						
2	Rigid Coupling	Aluminum	B85	AC46100	Aluminum	B85	AC46100
		Cast Iron	A48 Class 25	JL1030	Cast Iron	A48 Class 25	JL1030
3	Motor Adapter	Cast Iron	A48 Class 35	JL1040	Cast Iron	A48 Class 35	JL1040
4	Coupling Guard	Stainless Steel	A193-304	1.4301	Stainless Steel	A193-304	1.4301
5	Seal Housing	Stainless Steel	A193-304	1.4301	Stainless Steel	A193-316L	1.4404
6	Mechanical Seal	See Seal Materials Chart for Complete Details			See Materials Chart for Complete Details		
7	Plugs, Fill and Drain	Stainless Steel/O-Ring	A193-316	1.4401	Stainless Steel/O-Ring	A193-316	1.4401
8	Tie Rod	Zinc Plated Steel	B633	1.0765	Zinc Plated Steel	B633	1.0765
9	O-Ring, Sleeve	Viton (std) EPDM (opt)	B633		Viton (std) EPDM (opt)	B633	
10	Sleeve (casing)	Stainless Steel	A193-304	1.4301	Stainless Steel	A193-316L	1.4404
11	Diffuser	Stainless Steel	A193-316	1.4401	Stainless Steel	A193-316	1.4401
12	Impeller	Stainless Steel	A193-316	1.4401	Stainless Steel	A193-316	1.4401
13	Tungsten Carbide Sleeve	Tungsten Carbide			Tungsten Carbide		
14	Ceramic Bushing	Ceramic			Ceramic		
15	Shaft	Stainless Steel	A193-304	1.4301	Stainless Steel	A193-316	1.4401
16	Pump Body	Stainless Steel	A193-304	1.4301	Stainless Steel	A193-316L	1.4401
17	Pump Base	Aluminum	B85	AC46100	Aluminum	B85	AC46100

**Base Model: 33SV, 46SV, 66SV and 92SV**  
**Major Components**

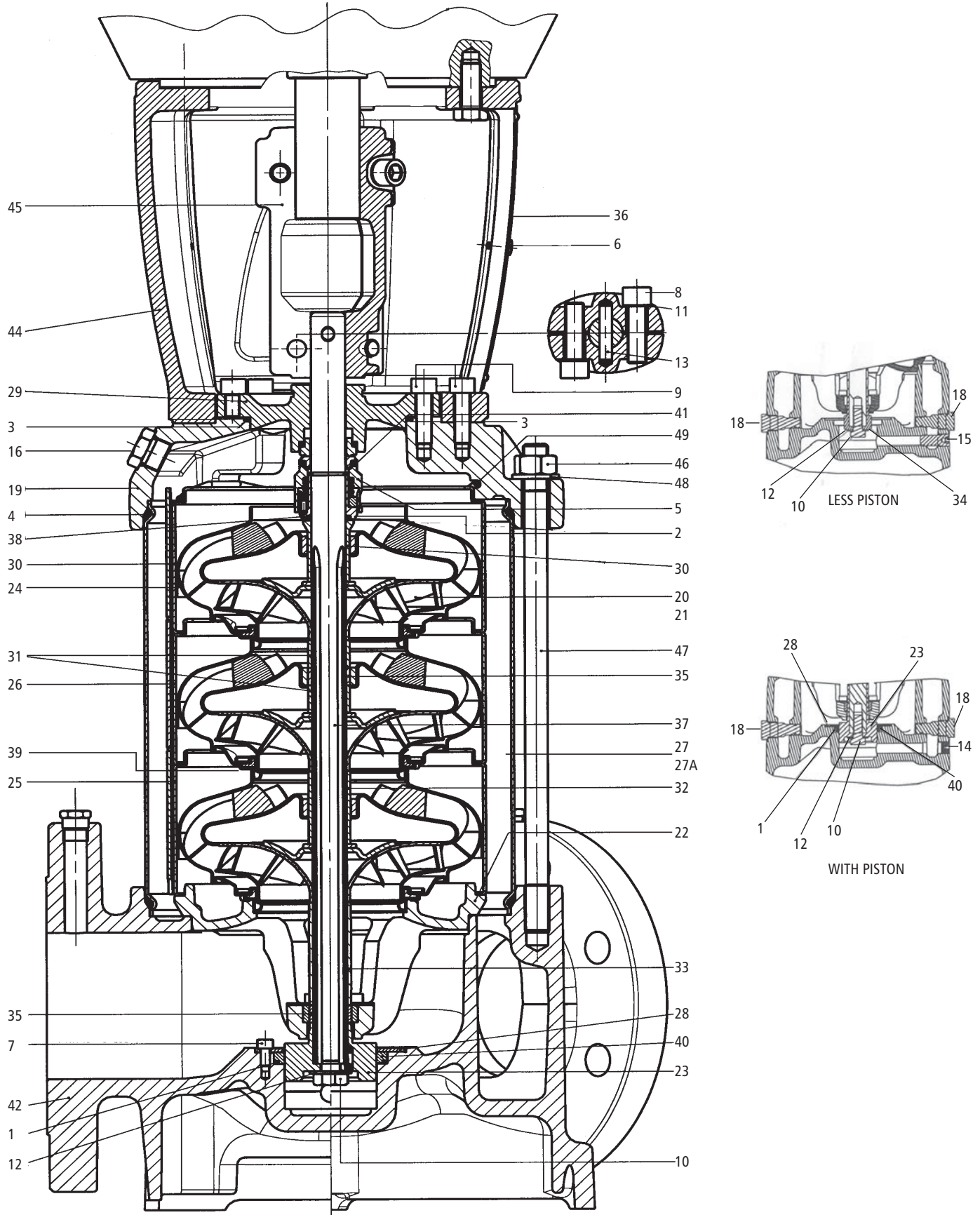

**Base Model: 33SV, 46SV, 66SV and 92SV**  
**Major Components**

No.	Description	SVB (33 – 92SV)			SVD (33 – 92SV)		
		Material	ASTM	DIN	Material	ASTM	DIN
1	O-Ring, Piston Seal	Viton (std) EPDM (opt)			Viton (std) EPDM (opt)		
2	O-Ring, Mechanical Seal Sleeve	Viton (std) EPDM (opt)			Viton (std) EPDM (opt)		
3	O-Ring, Seal housing	Viton (std) EPDM (opt)			Viton (std) EPDM (opt)		
4	O-Ring, Sleeve	Viton (std) EPDM (opt)			Viton (std) EPDM (opt)		
5	Mechanical Seal	See Seal Materials Chart for Complete Detail			See Seal Materials Chart for Complete Details		
5A	Cartridge Seal (not shown)	See Seal Materials Chart for Complete Detail			See Seal Materials Chart for Complete Details		
6	Screw, Guard	Stainless Steel	A193-304	1.4301	Stainless Steel	A193-304	1.4301
7	Screw, Piston Holding Disc	Stainless Steel	A193-316	1.4401	Stainless Steel	A193-316	1.4401
8	Screw, Coupling	Zinc Plated Steel	B363		Zinc Plated Steel	B633	
9	Screw, MA and Seal Housing	Zinc Plated Steel	B633		Zinc Plated Steel	B633	
10	Screw, Impeller	Stainless Steel	A193-316	1.4401	Stainless Steel	A193-316	1.4401
11	Washer, Coupling	Carbon Steel	A108		Carbon Steel	A108	
12	Washer, Impeller	Stainless Steel	A193-316	1.4401	Stainless Steel	A193-316	1.4401
13	Pin, Coupling	Carbon Steel	A108		Carbon Steel	A108	
14	Plug, with Piston	Stainless Steel	A193-316	1.4401	Stainless Steel	A193-316	1.4401
15	Plug, without Piston	Stainless Steel	A193-316	1.4401	Stainless Steel	A193-316	1.4401
16	Plug, Fill	Stainless Steel/O-Ring	A193-316	1.4401	Stainless Steel/O-Ring	A193-316	1.4401
17	Plug, Vent (not shown)	Stainless Steel/O-Ring	A193-316	1.4401	Stainless Steel/O-Ring	A193-316	1.4401
18	Plug, Drain	Stainless Steel/O-Ring	A193-316	1.4401	Stainless Steel/O-Ring	A193-316	1.4401
19	Pump Head	Cast Iron	A48 Class 35	JL1030	Stainless Steel	316 CF8M	1.4408
20	Impeller, Full Diameter	Stainless Steel	A193-316L	1.4404	Stainless Steel	A193-316L	1.4404
21	Impeller, Reduced Diameter	Stainless Steel	A193-316L	1.4404	Stainless Steel	A193-316L	1.4404
22	Lower Bearing Assembly	SS/Cast Iron	A193-316L/A48 Class 35	1.4404/JL1030	Stainless Steel	A193-316L/316 CF8M	1.4404/1.4408
23	Piston	Dupless SS	A182-F51	1.4462	Dupless SS	A182-F51	1.4462
24	Diffuser, Final	Stainless Steel	A193-316L	1.4404	Stainless Steel	A193-316L	1.4404
25	Diffuser with Carbon Bushing	Stainless Steel	A193-316L	1.4404	Stainless Steel	A193-316L	1.4404
26	Diffuser with Tungsten Bushing	Stainless Steel	A193-316L	1.4404	Stainless Steel	A193-316L	1.4404
27	Outer Sleeve, 25 Bar	Stainless Steel	A193-316L	1.4404	Stainless Steel	A193-316L	1.4404
27A	Outer Sleeve, 40 Bar	Stainless Steel	A193-316L	1.4404	Stainless Steel	A193-316L	1.4404
28	Holding Disc, Piston Seal	Stainless Steel	A193-316L	1.4404	Stainless Steel	A193-316L	1.4404
29	Seal Housing	Cast Iron	A48 Class 35	JL1030	Stainless Steel	316 CF8M	1.4408
30	Spacer, Impeller Final	Stainless Steel	A193-316	1.4401	Stainless Steel	A193-316	1.4401
31	Spacer, Shaft Bushing	Stainless Steel	A193-316	1.4401	Stainless Steel	A193-316	1.4401
32	Spacer, Impeller	Stainless Steel	A193-316	1.4401	Stainless Steel	A193-316	1.4401
33	Spacer, Impeller Lower (66-92SV)	Stainless Steel	A193-316	1.4401	Stainless Steel	A193-316	1.4401
34	Bushing, Non-Piston	Stainless Steel	A193-316	1.4401	Stainless Steel	A193-316	1.4401
35	Tungsten Carbide Bushing	Tungsten Carbide			Tungsten Carbide		
36	Coupling Guard	Stainless Steel	A193-304	1.4301	Stainless Steel	304	1.4301
37	Shaft	Dupless SS	A182-F51	1.4462	Dupless SS	A183-F51	1.4462
38	Mechanical Seal Shaft Sleeve	Stainless Steel	A193-316	1.4401	Stainless Steel	A193-316	1.4401
39	Wear Ring, Impeller	PPS Glass Filled			PPS Glass Filled		
40	Piston Seal	Impregnated Carbon			Impregnated Carbon		
41	Stop Ring, Impeller	Stainless Steel	A193-316	1.4401	Stainless Steel	A193-316	1.4401
42	Pump Body	Cast Iron	A48 Class 35	JL1030	Stainless Steel	316 CF8M	1.4408
43	Motor Adapter Plate (not shown)	Cast Iron	A48 Class 25	JL1030	Cast Iron	A48 Class 25	JL1030
44	Motor Adapter	Cast Iron	A48 Class 25	JL1030	Cast Iron	A48 Class 25	JL1030
45	Coupling, Half	Cast Iron	A48 Class 25	JL1030	Cast Iron	A48 Class 25	JL1030
46	Nut, Tie-Rod	Zinc Plated Steel	B633		Zinc Plated Steel	B633	
47	Tie-Rod	Zinc Plated Steel	B633		Zinc Plated Steel	B633	
48	Washer, Tie-Rod	Zinc Plated Steel	B633		Zinc Plated Steel	B633	
49	Spring, Final Diffuser	Stainless Steel	A193-316	1.4401	Stainless Steel	A193-316	1.4401

# SSV Mechanical Seals

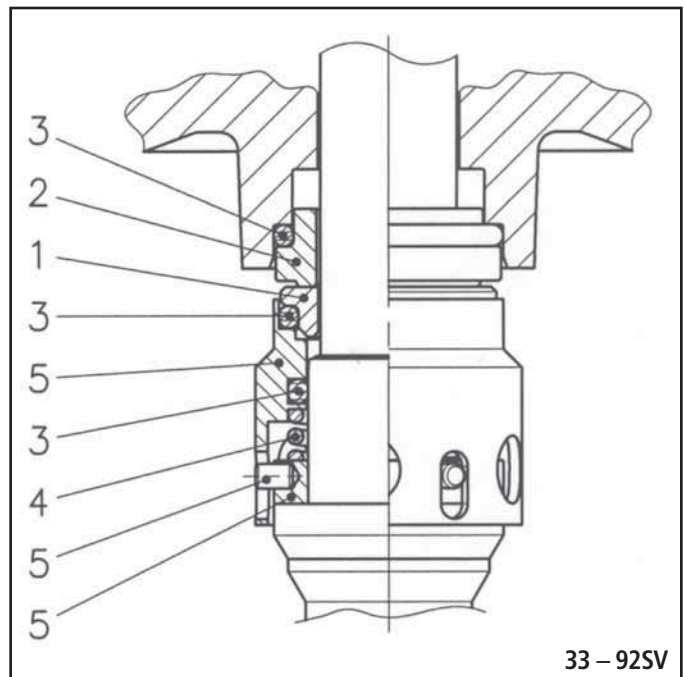
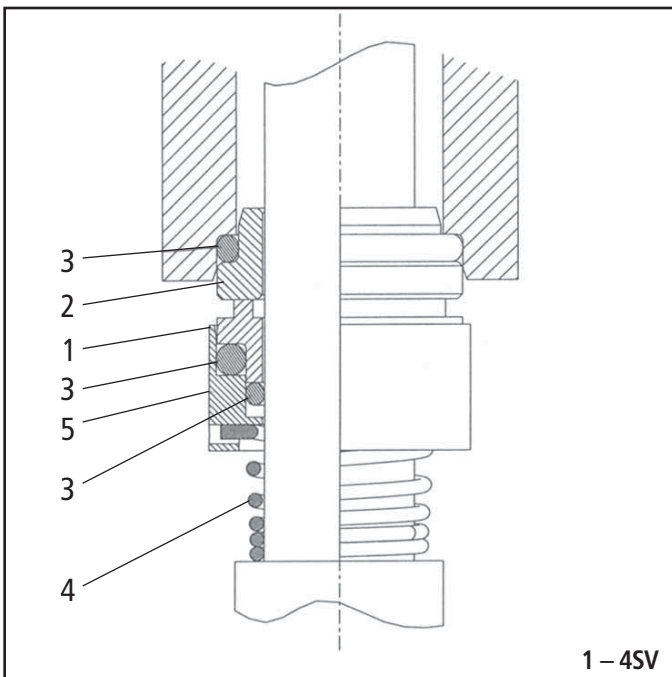

Pump	Rotating Face 1	Stationary Face 2	Elastomers 3	Spring 4	Metal Components 5	Elastomer Temp. Limits °F (°C)	Maximum Working Pressure	Application Use
1SV 2SV 3SV 4SV	Carbon	Silicon Carbide Graphite Filled	Viton	316SS	316SS	-14 – 392°F (-10 – 200°C)	363 psi (25 bar)	General Service
	Silicon Carbide Graphite Filled							Abrasive
	Carbon	EPR	-30 – 300°F (-34 – 150°C)			Boiler Feed		
33SV 46SV 66SV 92SV	Carbon	Silicon Carbide Graphite Filled	Viton	316SS	316SS	-14 – 392°F (-10 – 200°C)	580 psi (40 bar)	General Service
	Silicon Carbide Graphite Filled							Abrasive
	Carbon	EPR	-22 – 250°F (-30 – 120°C)			Boiler Feed		

NOTE: Pump max. temperature limit is 250°F.

## OPTIONAL CARTRIDGE SEAL

Pump	Rotating Face 1	Stationary Face 2	Elastomers 3	Spring 4	Sleeve 5	Set Screw 6	Locking Collar
33SV	Silicon Carbide	Carbon	Viton	316SS	316SS	300SS	316SS
46SV		Silicon Carbide					
66SV		Silicon Carbide	EPR				
92SV							

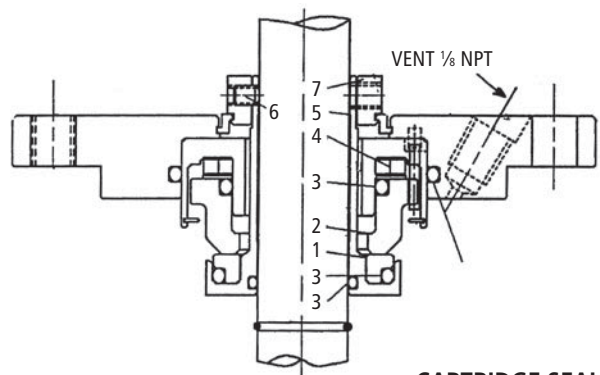

CARTRIDGE SEAL

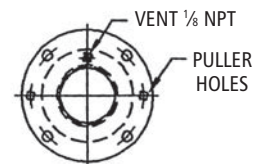

# Maximum Allowable Working Pressure Charts

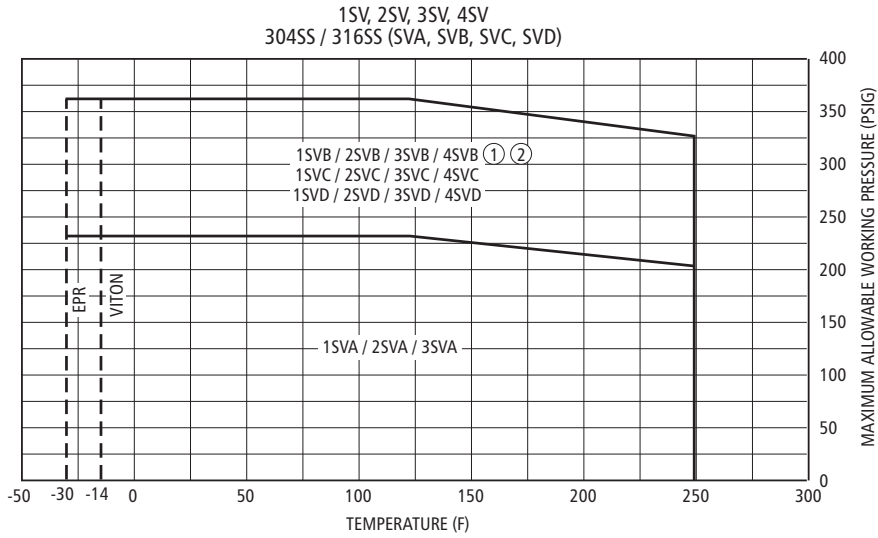

**NOTES:**

- ① Pressure rating for victaulic connections
- ② Some staging may have higher pressure rating. See pages 55-56.

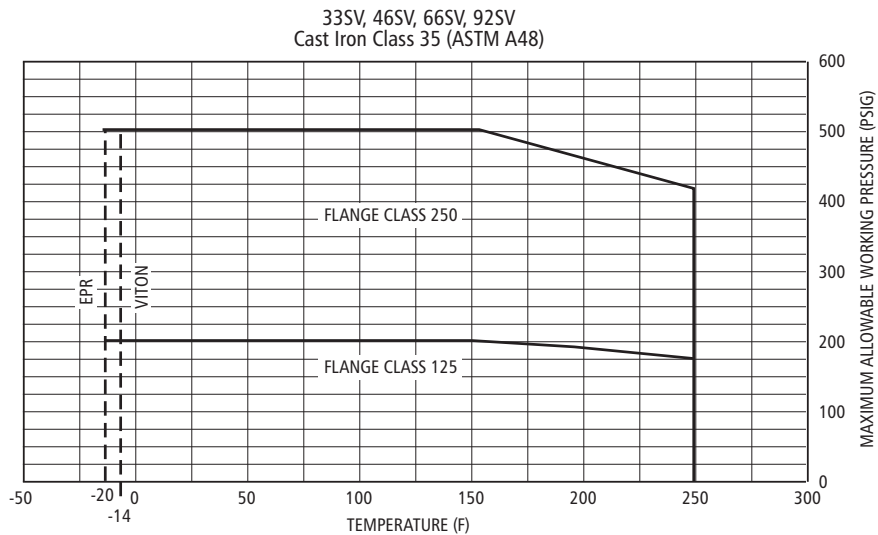
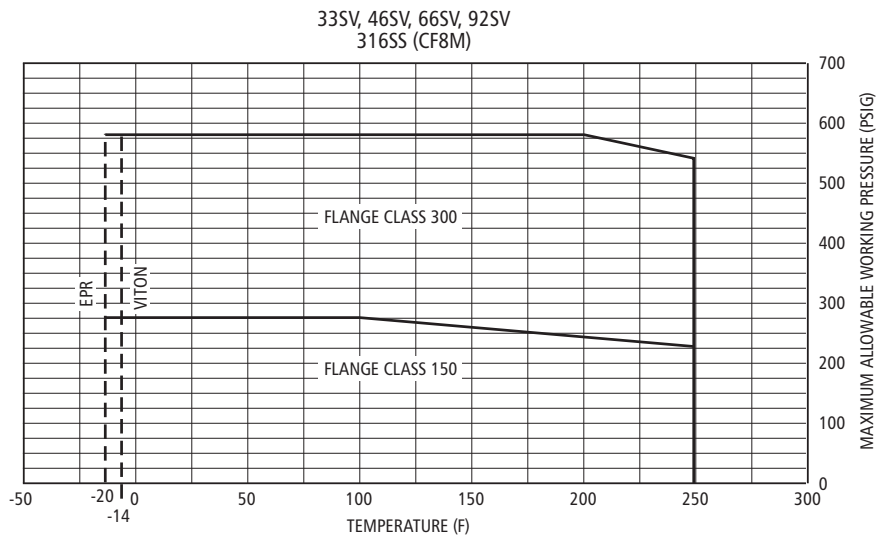

## Motor Data – Starts per Hour / Minimum Run Time

HP	Max Starts per Hour (evenly distributed)	Min. run time between starts (seconds)
1	15	75
1.5	13	76
2	12	77
3	9	80
5	8	83
7.5	7	88
10	6	92
15	5	100
20	5	110
25	5	115
30	4	120
40	4	130
50	3	145
60	3	170
75	3	180

### NOTE(S)

- 1) Recommended motor starts per hour and minimum run time calculated based on NEMA standards MG1-12.44 in accordance to manufacturers allowable tolerance for heat rise and insulation breakdown.
- 2) Applied voltage and frequency in accordance with NEMA MG1-12.44
- 3) Starts based on NEMA **three phase** design A and design B AC induction motors.
- 4) External load WK2 is equal to or less than the values listed in NEMA MG1-12.54
- 5) Applicable to all NEMA (JM, JP, T and TC frame) motors used for Goulds Pumps products.
- 6) Applicable to three phase motors only.

## Motor Data

### 3500 RPM, 60Hz

HP	Phase	Enclosure	Nameplate Voltage	NEMA Frame	Goulds PN ②	FLA	SFA	LRA ①	S.F.	Efficiency	Insulation Class
½	1	ODP	115/230	56C	V04721	7/3.6-3.5	7.9/4.06-3.95	21	1.15	66	B
		TEFC	115/230	56C	V04722	7/3.6-3.5	7.9/4.06-3.95	21	1.15	66	B
	3	ODP	230/460	56C	V04741	2.1/2-1	2.52/2.4-1.2	6	1.25	68	B
		TEFC	230/460	56C	V04742	2.1/2-1	2.52/2.4-1.2	6	1.25	68	B
		X-Proof	230/460	56C	V04743	2.1/2-1	NA	6	1	68	B
¾	1	ODP	115/230	56C	V05721	9.4/4.9-4.7	10.8/5.63-5.4	26	1.25	72	B
		TEFC	115/230	56C	V05722	9.6/5-4.8	11.4/5.94-5.7	28	1.25	66	B
	3	ODP	230/460	56C	V05741	2.7-2.6/1.3	3.15-3/1.5	7.6	1.25	74	B
		TEFC	230/460	56C	V05742	2.7-2.6/1.3	3.15-3/1.5	7.6	1.25	74	B
		X-Proof	230/460	56C	V05743	2.7-2.6/1.4	NA	7.6	1	74	B
		Prem. Eff. TEFC	230/460	56C	V05742PE	2.0/1.0	2.3/1.15	7	1.15	82.5	B
1	1	ODP	115/230	56C	V06721	15/7.9-7.5	15.8/8.217.9	48	1.25	65	B
		TEFC	115/230	56C	V06722	11/5.5	13.5/6.75	38.5	1.25	66	B
	3	ODP	230/460	56C	V06741	3.7-3.6/1.8	3.99-3.8/1.9	11	1.25	75.5	B
		TEFC	230/460	56C	V06742	3.7-3.6/1.8	3.99-3.8/1.9	11	1.25	75.5	B
		X-Proof	230/460	56C	V06743	3.7-3.6/1.9	NA	11	1	75.5	B
		Prem. Eff. TEFC	230/460	56C	V06742PE	2.8/1.4	3.12/1.56	12.1	1.25	84.5	B
1½	1	ODP	115/230	56C	V07721	12.8/7-6.4	14.5/7.9-7.3	76	1.15	80	B
		TEFC	115/230	56C	V07722	16/8.4-8	18/10-9	50	1.15	70	B
	3	ODP	230/460	56C	V07741	4.9-4.6/2.3	5.3-5.1/2.54	18.4	1.15	80	B
		TEFC	230/460	56C	V07742	4.9-4.6/2.3	5.3-5.1/2.54	18.4	1.15	80	B
		X-Proof	230/460	56C	V07743	5-4.6/2.3	NA	16	1	75.5	B
		Prem. Eff. ODP	230/460	56C	V07741PE	4.2/2.1	4.6/2.3	16	1.15	85.5	B
Prem. Eff. TEFC	230/460	56C	V07742PE	4.0/2.0	4.5/2.25	20.1	1.15	85.5	B		
2	1	ODP	115/230	56C	V08721	24/12.6-12	28.6/14.3	80	1.15	70	B
		TEFC	115/230	56C	V08722	23/12-11.5	24.2/12.1	78	1.15	74	B
	3	ODP	208-230/460	56C	V08741	6.2-5.8/2.9	7.2-6.52/3.26	22	1.15	80	B
		TEFC	208-230/460	56C	V08742	6.2-5.8/2.9	7.2-6.52/3.26	22	1.15	80	B
		X-Proof	208-230/460	56C	V08743	5.4/2.7	N/A	17.5	1	78.5	B
		Prem. Eff. ODP	208-230/460	56C	V08741PE	5.5-5/2.5	6.2-5.6/2.8	22	1.15	86.5	B
Prem. Eff. TEFC	208-230/460	56C	V08742PE	5/4.75-2.5	6.4-5.8/2.9	30	1.15	86.5	B		
3	1	ODP	230	56C	V09721	14.4/13	16.4-14.8	108	1.15	82.5	B
		TEFC	115/230	56C	V09722	27/13.5	33/18/16.5	11.4	1.15	80	F
	3	ODP	208-230/460	56C	V09741	8.5-8/4	10-9/4.5	30.9	1.15	80	F
		TEFC	208-230/460	56C	V09742	8.1-7.6/3.8	9.5-8.6/4.3	32.9	1.15	82.5	F
		X-Proof	208-230/460	56C	V09743	7.8-7.4/3.7	NA	27	1	82.5	F
		Prem. Eff. ODP	208-230/460	56C	V09741PE	7.4/3.7	9.1-8.2/4.1	29	1.15	87.5	F
Prem. Eff. TEFC	208-230/460	184TC	V09742PE	6.8/3.4	8.5-7.7/3.8	32	1.15	88.5	F		
5	1	ODP	208-230	184TC	V10721A	24-23	30.1-27.2	125	1.15	75	F
		TEFC	208-230	184TC	V10722A	23.5	41.8-37.8	110	1.15	84	F
	3	ODP	208-230/460	184TC	V10741A	13.1-11.5/5.7	15.3-13.8/6.9	48	1.15	84	F
		TEFC	208-230/460	184TC	V10742A	13.2-12/6	15-13.6/6.8	47	1.15	85.5	F
		X-Proof	230/460	184TC	V10743A	13.2-12/6	NA	47	1	85.5	F
		Prem. Eff. ODP	208-230/460	184TC	V10741APE	11.2/5.6	14.4-13/6.5	55	1.15	90.2	B
Prem. Eff. TEFC	208-230/460	184TC	V10742APE	11.2/5.7	14.4-13/6.5	55	1.15	90.2	F		

## Motor Data

### 3500 RPM, 60Hz

HP	Phase	Enclosure	Nameplate Voltage	NEMA Frame	Goulds PN <sup>②</sup>	FLA	SFA	LRA <sup>①</sup>	S.F.	Efficiency	Insulation Class
7.5	1	ODP	230	213TC	V11721	29	35	185	1.15	84	F
		TEFC	230	213TC	V11722	35	NA	220	1	83	F
	3	ODP	208-230/460	184TC	V11741A	19	22.3-20.2/10.1	76	1.15	88.5	F
		ODP	208-230/460	184TC	V11741BB	19-18/9	22.3-20.2/10.1	76	1.15	85.5	B
		TEFC	208-230/460	184TC	V11742BB	18.3-17.4/8.7	21.7-19.7/9.8	99	1.15	88.5	F
		TEFC	208-230/460	184TC	V11742A	18.5/17.4	21.7-19.6/9.8	94	1.15	88.5	F
		X-Proof	230/460	184TC	V11743A	17.6/8.8	N/A	76	1.15	87.5	B
		Prem. Eff. ODP	208-230/460	184TC	V11741APE	16.8/8.4	21.2-19.2/9.6	87	1.15	90.2	F
Prem. Eff. TEFC	230/460	213TC	V11742APE	17.8/8.9	20.2/10.1	75	1.15	90.2	F		
10	1	ODP	230	213TC	V12721	48-46	51.6	280	1.15	83	F
		TEFC	230	213TC	V12722	40	NA	284	1	82	F
	3	ODP	208-230/460	213TC	V12741	25.6-23.2/11.6	29.9-27/13.5	67	1.15	88.5	F
		TEFC	208-230/460	215TC	V12742	25-24/12	30.5-27.6/13.8	105	1.15	85.5	F
		X-PROOF	230/460	215TC	V12743	23.2/11.6	35.2/17.6	99.2	1.15	89.5	F
		Prem. Eff. ODP	208-230/460	213TC	V12741PE	23/11.5	29.2-26.4/13.2	98	1.15	91.7	F
Prem. Eff. TEFC	230/460	215TC	V12742PE	23.8/11.9	27.6/13.8	112	1.15	89.5	F		
15	3	ODP	208-230/460	215TC	V13741	35/17.5	43.8-39.6/19.8	124	1.15	89.5	F
		TEFC	208-230/460	254TC	V13742	35/17.5	43-39/19.5	165	1.15	86.5	F
		X-Proof	230/460	254TC	V13743	35.6/16.8	38.8/19.4	108	1.15	90.2	F
		Prem. Eff. ODP	208-230/460	215TC	V13741PE	34/17	43.8-39.6/19.8	143	1.15	91.7	F
		Prem. Eff. TEFC	208-230/460	254TC	V13742PE	34.4/17.2	43.8-39.6/19.8	112	1.15	91.7	F
20	3	ODP	230/460	254TC	V14741	46/23	51.4/25.7	175	1.15	87.5	F
		TEFC	208-230/460	256TC	V14742	46/23	59.3-53.6/26.8	160	1.15	89.5	F
		X-Proof	230/460	256TC	V14743	46/23	51.6/25.8	153	1.15	90.2	F
		Prem. Eff. ODP	208-230/460	254TC	V14741PE	45/22.5	57.5-52/26	144.8	1.15	92.4	F
		Prem. Eff. TEFC	208-230/460	256TC	V14742PE	46/23	57.5-52/26	201	1.15	92.4	F
25	3	ODP	208-230/460	256TC	V15741	60/30	75.9-68.6/34.3	160	1.15	88.5	F
		TEFC	208-230/460	284TC	V15742	59/29.5	74.8-67.6/33.8	182	1.15	88.5	F
		ODP	208-230/460	256TC	V15741BB	65-60/30	75.9-68.6/34.3	160	1.15	88.5	B
		TEFC	208-230/460	256TC	V15742BB	62-56/28	72.3-65.4/32.7	184	1.15	90.2	F
		X-Proof	230/460	284TC	V15743	57/28.5	66/33	204	1.15	91	F
		Prem. Eff. ODP	230/460	256TC	V15741PE	58/29	66.8/33.4	204	1.15	92.4	F
		Prem. Eff. TEFC	230/460	284TC	V15742PE	56/28	69.9-63.2/31.6	236	1.15	93	F
30	3	ODP	208-230/460	284TC	V16741	70/35	80.6/40.3	190	1.15	91	F
		TEFC	208-230/460	284TC	V16742	68/34	86.7-78.4/39.2	225	1.15	91	F
		X-Proof	230/460	286TC	V16743	70/35	80.5/40.25	248	1.15	91	F
		Prem. Eff. ODP	230/460	284TC	V16741PE	68/34	77.4/38.7	234	1.15	93.6	F
		Prem. Eff. TEFC	230/460	286TC	V16742PE	66/33	83.8-75.8/37.9	281	1.15	93	F
40	3	ODP	230/460	284TC	V17741	96/48	108.4/54.2	271	1.15	91	F
		TEFC	230/460	284TC	V17742	90/45	103.2/51.6	322	1.15	90.2	F
		X-Proof	230/460	324TSC	V17743	90/45	104.2/52.1	285	1.15	91.7	F
		Prem. Eff. ODP	230/460	286TC	V17741PE	110/55	127.4/63.7	408	1.15	94.1	F
		Prem. Eff. TEFC	230/460	324TSC	V17742PE	90/45	102.2/51.1	286	1.15	93.6	F
50	3	ODP	230/460	326TSC	V18741S	118/59	137/68.5	320	1.15	89.5	F
		TEFC	230/460	326TSC	V18742S	112/56	141.8-128.2/64.1	430	1.15	92.4	F
		X-Proof	230/460	326TSC	V18743S	112.00/56	129/64.5	407	1.15	92.4	F
		Prem. Eff. ODP	230/460	324TSC	V18741SPE	110/55	127.4/63.7	408	1.15	94.1	F
		Prem. Eff. TEFC	230/460	326TSC	V18742SPE	108/54	124.8/62.4	422	1.15	94.1	F

## Motor Data

HP	Phase	Enclosure	Nameplate Voltage	NEMA Frame	Goulds PN ②	FLA	SFA	LRA ①	S.F.	Efficiency	Insulation Class
60	3	ODP	230/460	326TSC	V19741S	136/68	157.4/78.7	472	1.15	93	F
		TEFC	230/460	364TSC	V19742S	138/69	173.6-157/78.5	422	1.15	90.2	F
		X-Proof	230/460	364TSC	V19743S	134/67	154.4/77.2	448	1.15	93	F
		Prem. Eff. ODP	230/460	326TSC	V19741SPE	130/65	149.4/74.7	493	1.15	94.5	F
		Prem. Eff. TEFC	230/460	364TSC	V19742SPE	134/67	150.8/75.4	580	1.15	94.1	F
75	3	ODP	230/460	365TSC	V20741S	168/84	213-193/96.5	639	1.15	93	F
		TEFC	230/460	365TSC	V20742S	168/84	213-192.8/96.4	650	1.15	91	F
		X-Proof	230/460	365TSC	V20743S	164/82	189/94.5	618	1.15	93	F
		Prem. Eff. ODP	230/460	364TSC	V20741SPE	164/82	188.8/94.4	557	1.15	94.5	F
		Prem. Eff. TEFC	230/460	365TSC	V20742SPE	166/83	188.8/94.4	740	1.15	94.5	F

**NOTES:**

① Locked rotor amps are for high voltage only.

② Vertical footless motor PN.

- Motors are suitable for AQUAVAR® Variable Speed Drive.

Above data is for Baldor® TC and TSC frame motors. Specifications subject to change without notice.

# Dimensions and Weights

## 1SV Series 3500 RPM

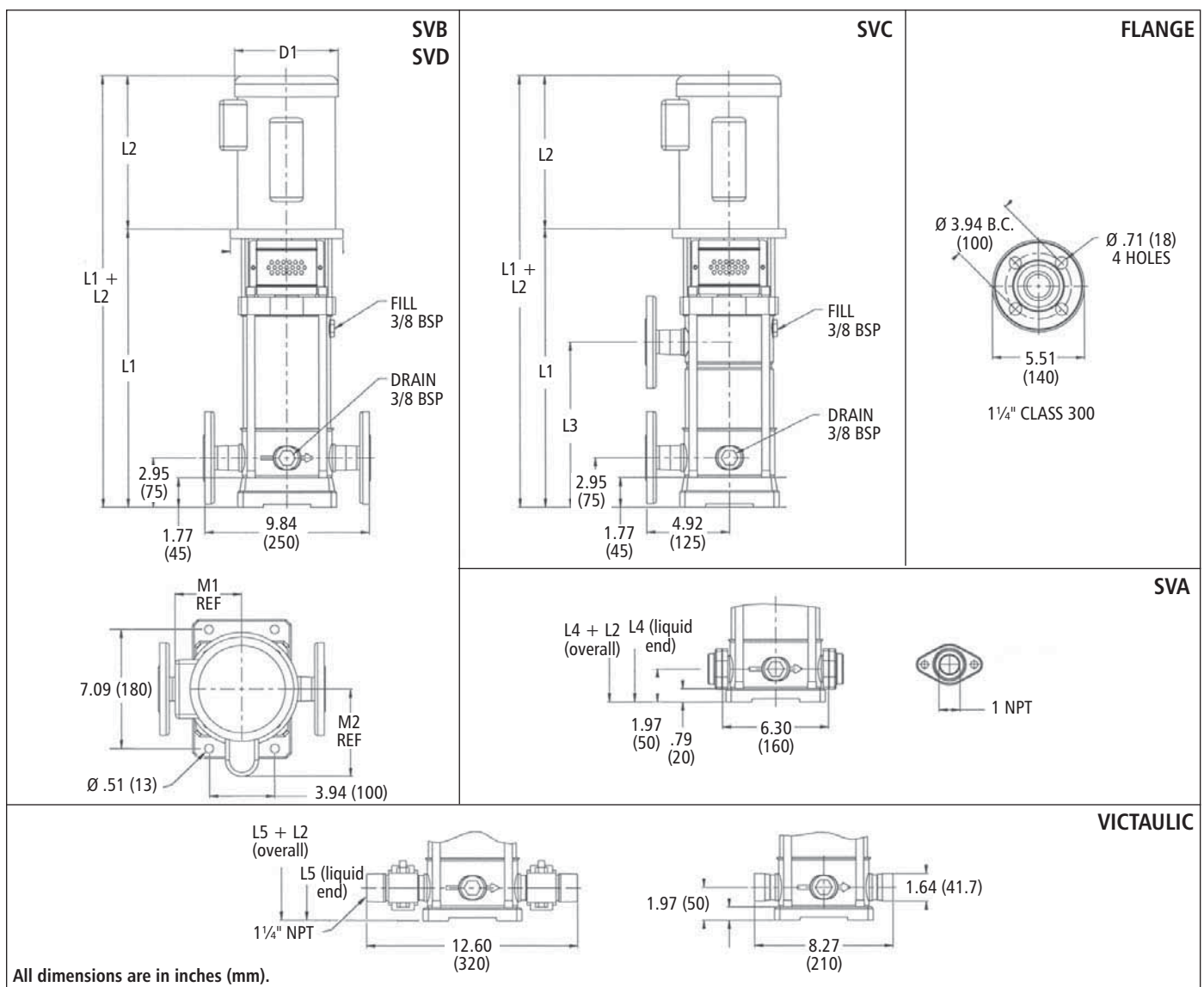

Stage	Frame (1-Phase)		Frame (3-Phase)										D1 (max.)		Weights (lb)											
	ODP	TEFC	ODP	TEFC	HP	L1	ODP	TEFC	L3	L4	L5	M1 (ref.)	M2 (ref.)	ODP	TEFC	Liquid End	ODP	TEFC								
2	56C	56C	1/2	12.69	9.16	9.29	11.19	11.69	11.69	5.06	5.19	6.19	6.19	6.19	6.19	21	22	22								
3			3/4	13.63	10.79	9.91										12.69	12.69	22	24	28						
4			1	14.63	10.66	11.19										13.63	13.63	23	32	40						
5			1 1/2	15.63	10.67	8.88										14.63	14.63	25	40	43						
6			2	16.63	11.19	12.06										9.88	15.63	15.63	27	43	51					
7			17.56	11.19	10.81	16.63										16.63	5.73	28	51	56						
8			18.56	11.19	11.81	17.56										17.56	5.55	29	51	56						
9			19.56	11.57	12.81	18.56										18.56	5.50	30	51	56						
11			20.50	11.57	13.44	18.56										18.56	7.16	33	51	56						
13			182-4TC	182-4TC	5	23.50										13.93	15.43	16.75	22.50	6.87	6.62	8.50	8.50	35	75	85
15						18.69												24.44						37		
16	19.69	25.81				39																				
18	27.50	41																								
20	213TC	213TC	7 1/2	30.44	13.93	15.43	29.50	31.50	6.87	6.62	8.50	8.50	44	101	124											
22				32.44			31.50						46													

# 1SV Curve 3500 RPM

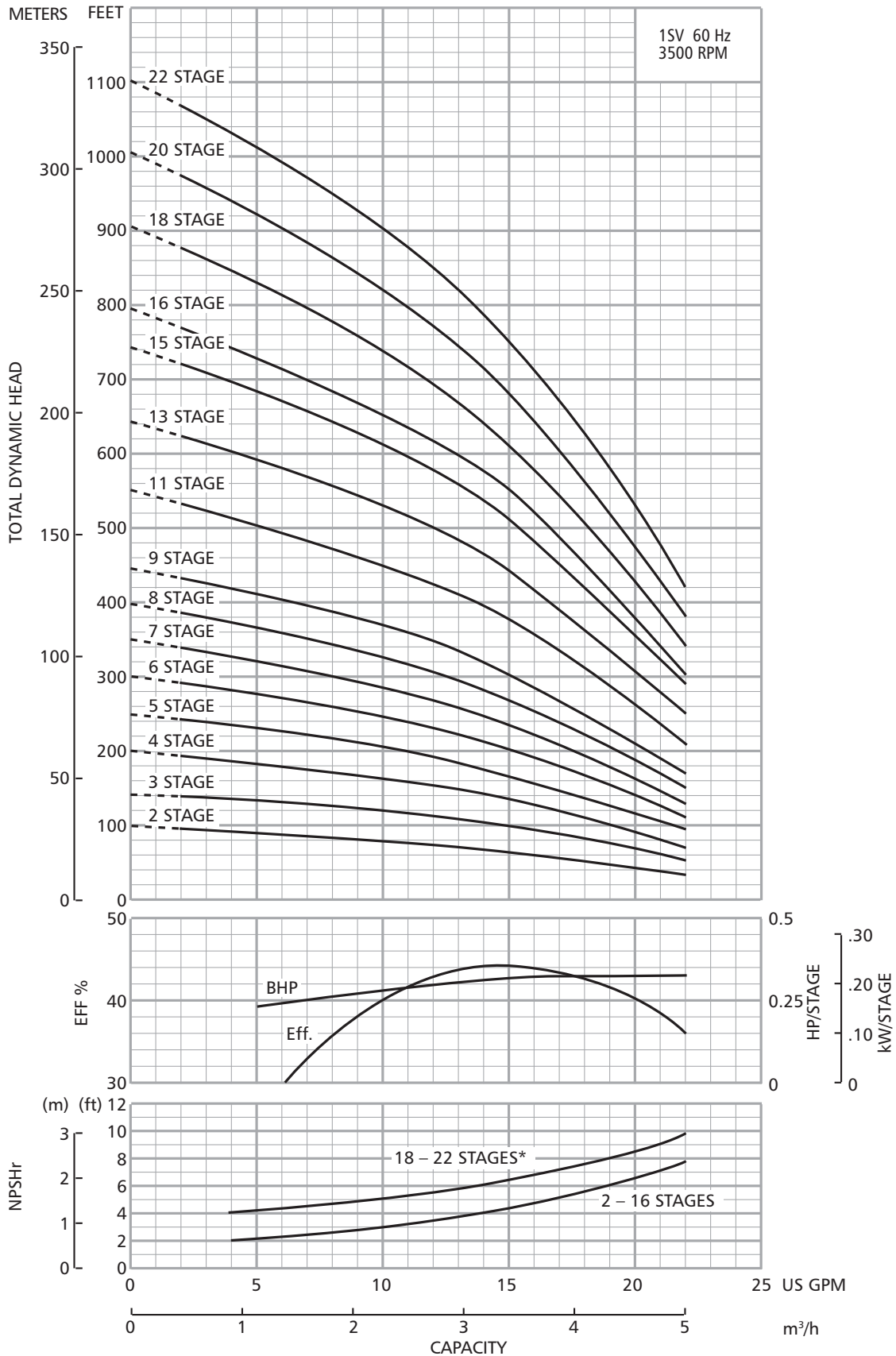

\* For vertical shaft installation only.

# Dimensions and Weights

## 2SV Series 3500 RPM

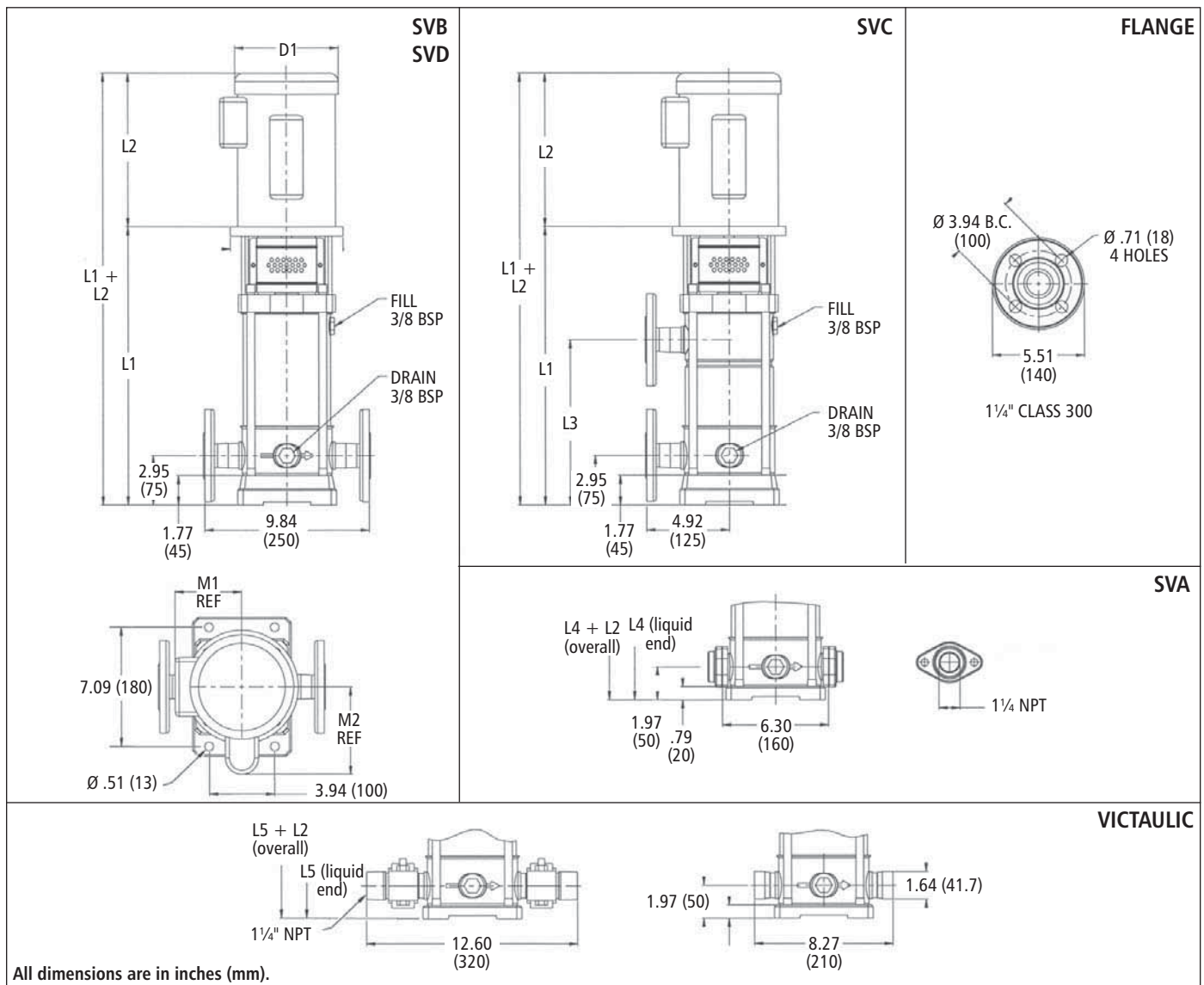

Stage	Frame (1-Phase)		Frame (3-Phase)				L2					D1 (max.)		Weights (lb)								
	ODP	TEFC	ODP	TEFC	HP	L1	ODP	TEFC	L3	L4	L5	M1 (ref.)	M2 (ref.)	ODP	TEFC	Liquid End	ODP	TEFC				
2	56C		56C		3/4	12.69	10.75	9.94	11.19	11.69	11.69	5.06	5.19	6.19	6.19	21	24	28				
3					1	13.63	10.63	12.69		12.69	5.75	5.56	22			32	40					
4					1 1/2	14.63	10.69	13.63		13.63			24			40	43					
5					56C		56C		2	15.63	11.19	12.06	8.88	14.63	14.63	5.50	5.56	7.19	7.19	25	43	51
6										16.63			9.88	15.63	15.63					26		
7									17.56	10.81	16.63	16.63	28									
8									3	18.56	11.56	13.88	11.81	17.56	17.56					30	51	56
9										19.56			12.81	18.56	18.56					31		
11					182-4TC		182-4TC		5	21.50	13.94	15.44	14.75	20.56	20.56	6.88	6.63	8.50	8.50	33	75	85
13	23.50	18.69	22.50	35																		
15	25.44			24.44						39												
16	26.44			26.44						40												
18	184TC		184TC		7 1/2	28.44	13.94	15.44	18.69	28.44	32.44	6.88	6.63	8.50	8.50	42	101	124				
20						30.44										30.44			44			
22						32.44										32.44			46			

# 2SV Curve 3500 RPM

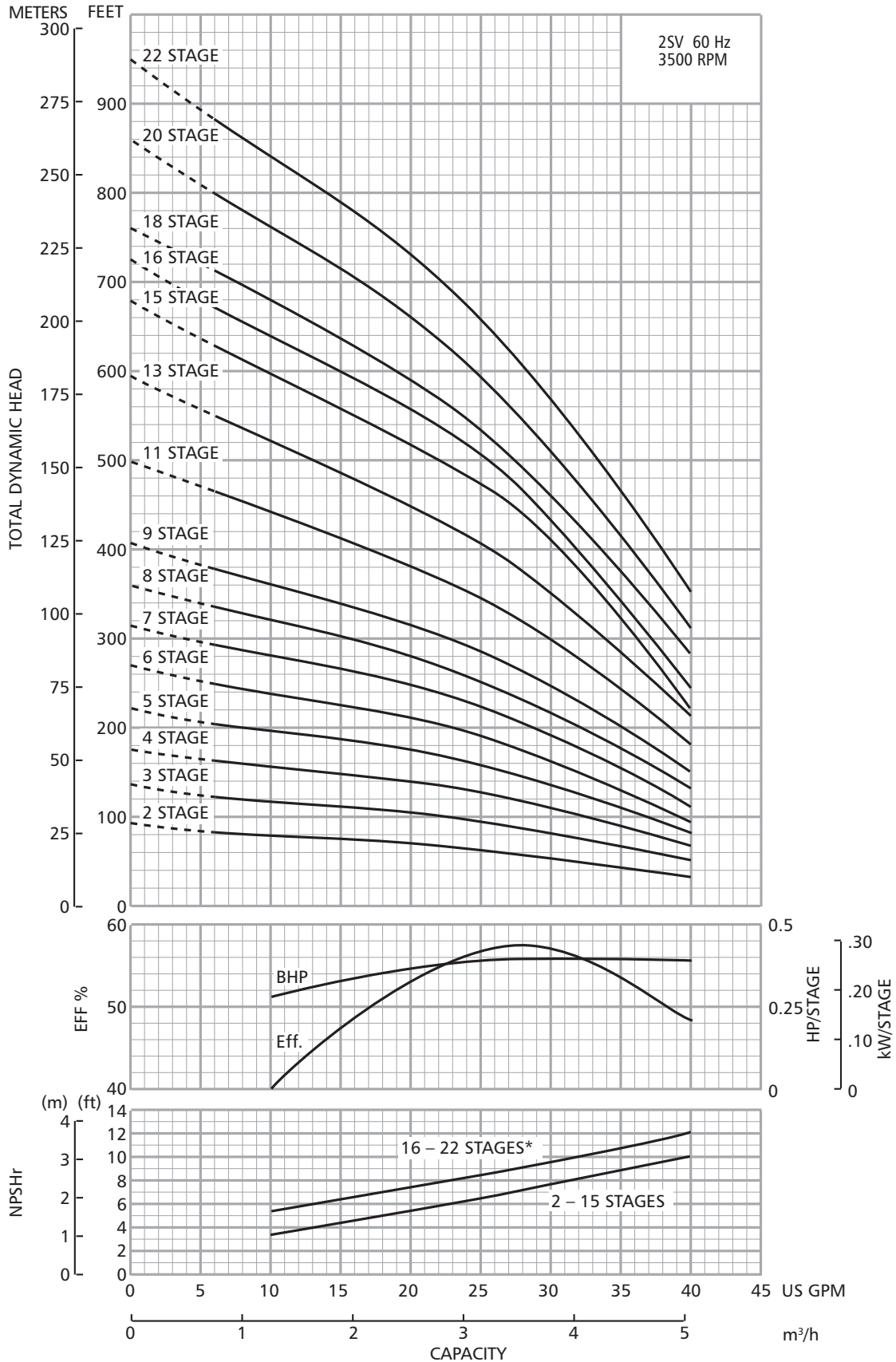

\* For vertical shaft installation only.

# Dimensions and Weights 3SV Series 3500 RPM

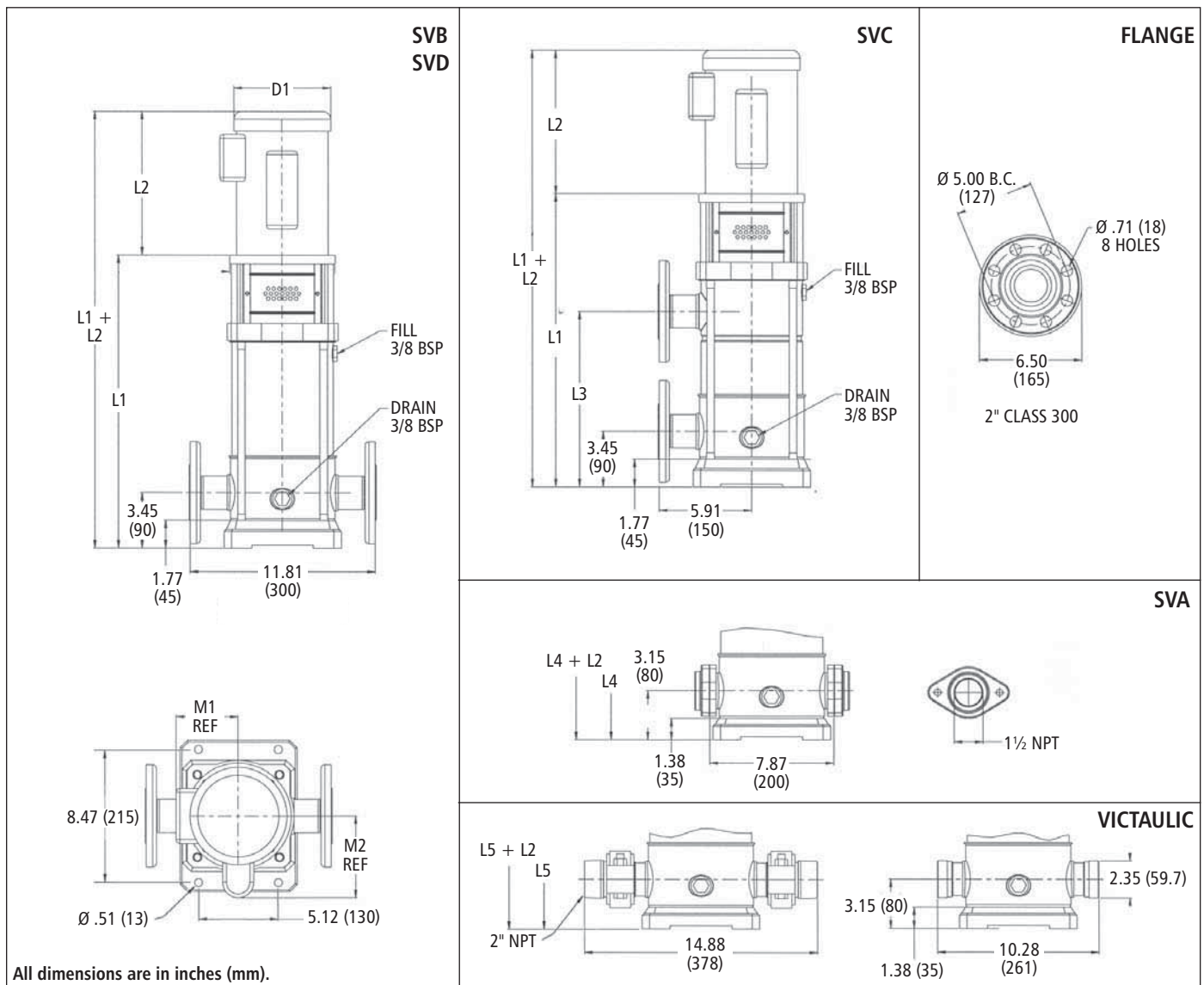

Stage	Frame (1-Phase)		Frame (3-Phase)		HP	L1	L2		L3	L4	L5	M1 (ref.)	M2 (ref.)	D1 (max.)		Weights (lb)		
	ODP	TEFC	ODP	TEFC			ODP	TEFC						L3	L4	L5	ODP	TEFC
2	56C		56C		2	15.75	11.19	12.06		15.31	15.31	5.75	5.56	7.19	7.19	33	43	51
3					3	17.25	11.56	13.88		16.81	16.81		5.50			35	51	56
4	182-4TC		182-4TC		5	18.75	13.94	15.44	11.81	18.31	18.31	6.88	6.63	8.50	8.50	37	75	85
5						20.25			12.69	19.81	19.81							
6					7½	23.25	13.94	15.44	15.69	22.81	22.81	6.88	6.63	8.50	8.50	44	101	124
7	213TC		182-4TC			24.69			17.19	24.25	24.25							
8																		
9					10	28.88	15.56	15.50	20.19	28.44	8.06	8.77	10.25	10.25	47	130	151	
10	213TC		213TC	215TC		30.38			21.69						29.94			
11																		
12					15	33.38	15.56	16.56	24.63	32.94	9.25	10.19	10.83	64	128	250		
13			215TC	254TC		34.50			34.19					37.19				
14																		
16			254TC	256TC	20	35.88									72	220	280	

# 3SV Curve 3500 RPM

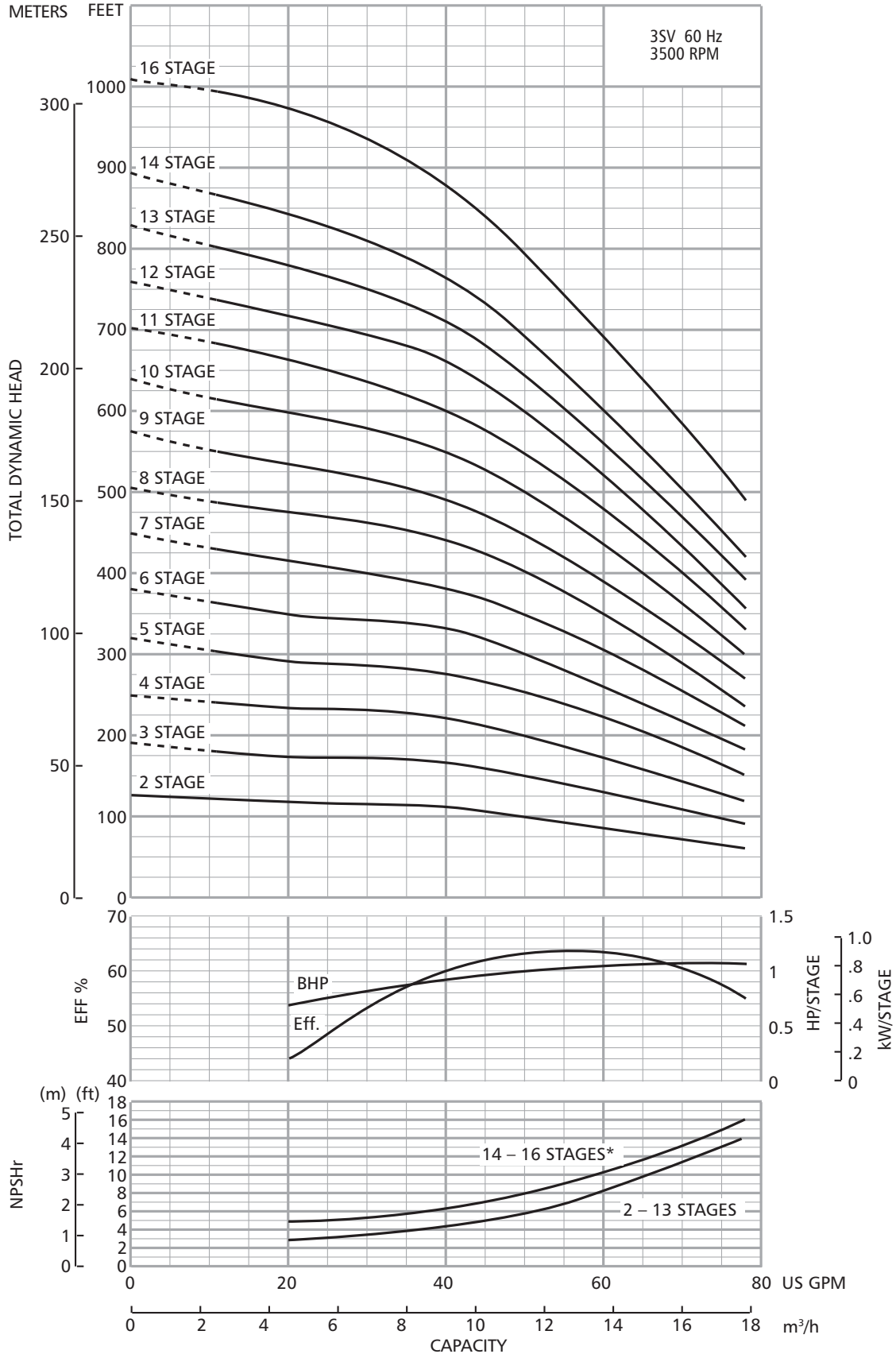

\* For vertical shaft installation only.

# Dimensions and Weights

## 4SV Series 3500 RPM

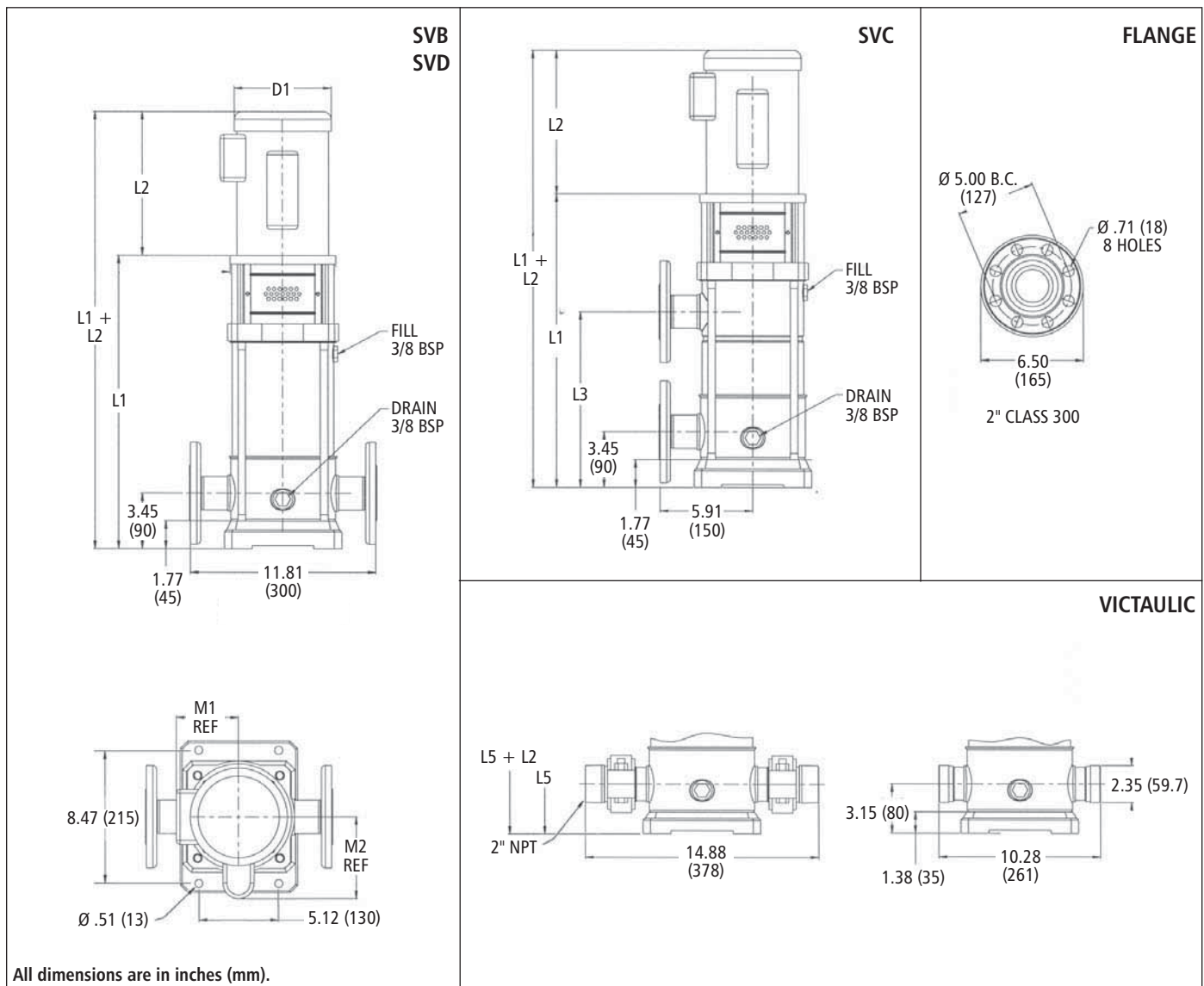

Stage	Frame (1-Phase)		Frame (3-Phase)		HP	L1	L2		L3	L5	M1 (ref.)	M2 (ref.)	D1 (max.)		Weights (lb)						
	ODP	TEFC	ODP	TEFC			ODP	TEFC					ODP	TEFC	Liquid End	ODP	TEFC				
2	182-4TC		182-4TC		5	15.75	13.94	15.44	15.75	17.25	6.88	6.63	8.50	8.50	33	75	85				
3	213TC				7½	17.25									35	101	124				
4					7½	18.75									39	101	124				
5			213TC	215TC	10	21.44	15.56	16.56	12.69	21.44	8.06	8.77	10.25	48	130	151					
6			215TC	254TC	15	24.44								15.69	24.44	9.25	10.19	10.31	50	128	250
7					15	24.44								15.69	24.44				52		
8			254TC	256TC	20	28.88	17.19	25.94	55	220	280										
9					20	28.88	17.19	25.94	55												
10			256TC	25	31.88	15.56	16.56	20.19	28.88	9.25	10.19	10.31	65	220	280						
11													25			31.88	15.56	16.56	20.19	28.88	9.25
12			256TC		25	31.88	15.56	16.56	31.88	9.25	10.19	10.31	11.63	79	240	300					

# 4SV Curve

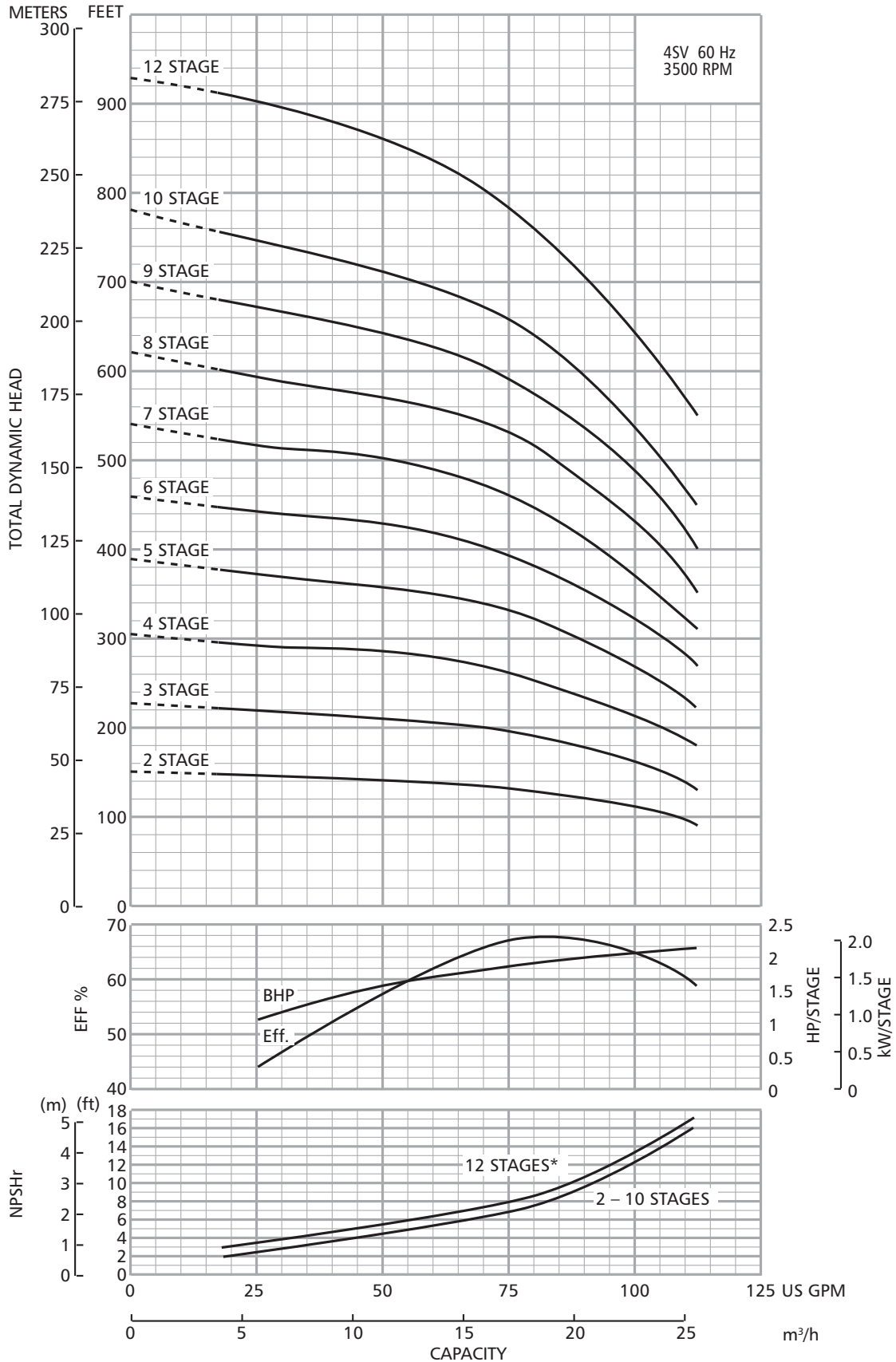

\* For vertical shaft installation only.

# Dimensions and Weights

## 33SV Series 3500 RPM

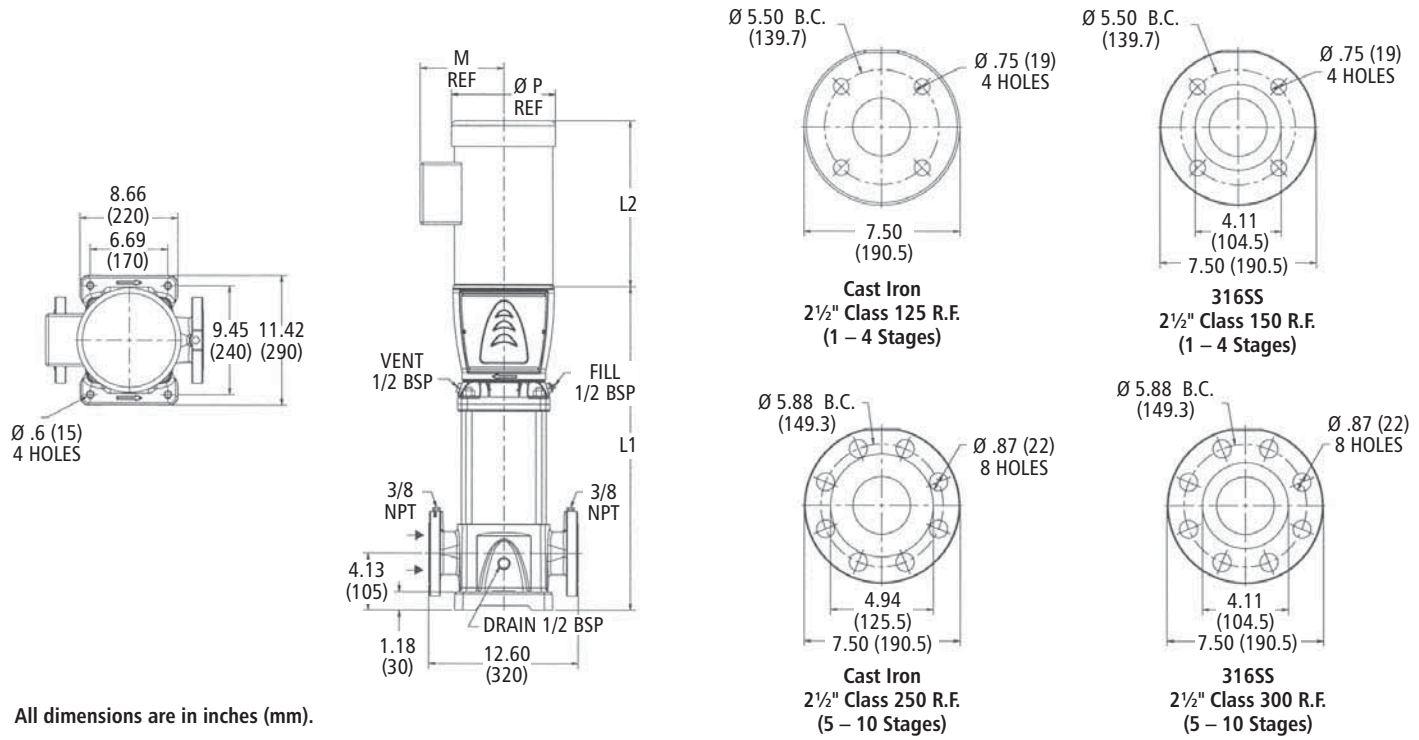

All dimensions are in inches (mm).

Stage	Frame (1-Phase)		Frame (3-Phase)		HP	L1	L2		M (ref.)	D1		Weights (lb)		
	ODP	TEFC	ODP	TEFC			ODP	TEFC		ODP	TEFC	Liquid End	ODP	TEFC
1/1	182-4TC		182-4TC		5	20.62	13.94	15.44	6.88	8.50	8.50	132	75	85
1					7½									
2/2	213TC		213TC 215TC		10	23.58	15.50	15.56	8.06	10.19	10.25	143	130	151
2/1														
2														
3/2														
3/1	254TC		254TC 256TC		15	26.54	15.56	16.56	9.25	10.19	10.31	152	128	250
3														
4/2														
4/1														
4														
5/2					256TC									
5/1														
5	284TC		284TC		30	35.40	20.12	23.38	13.12	13.25	15.30	172	240	420
6/2														
6/1														
6														
7/2														
7/1														
7														
8/2														
8/1	326TSC		326TSC		40	44.25	22.5	23.38	13.12	13.25	15.30	172	240	420
8														
9/2														
9/1														
9	326TSC		326TSC		50	47.20	22.5	23.38	13.12	13.25	15.30	172	240	420
10/2														
10/1														
10														

# 33SV Curve 3500 RPM

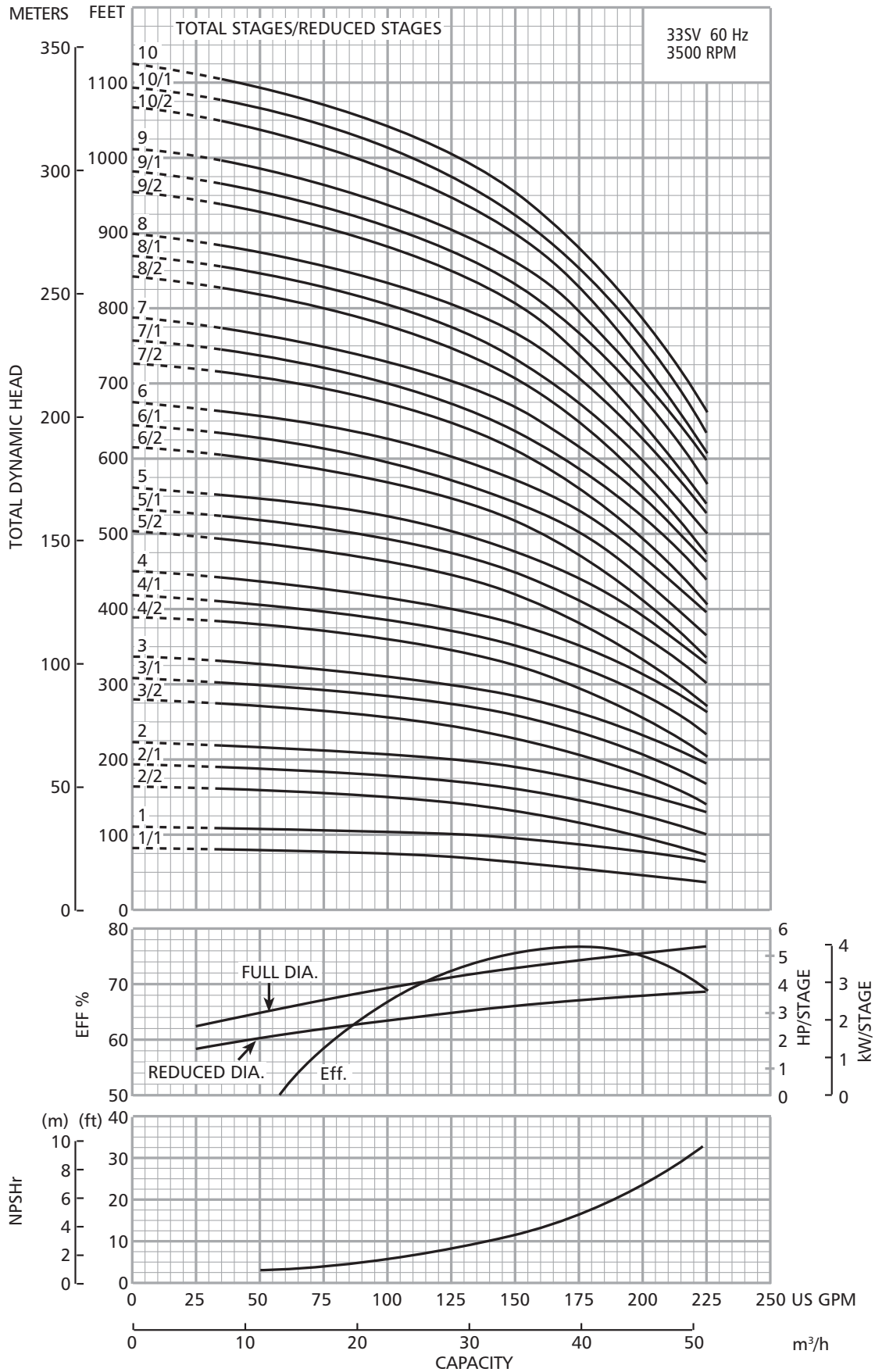

# Dimensions and Weights

## 46SV Series 3500 RPM

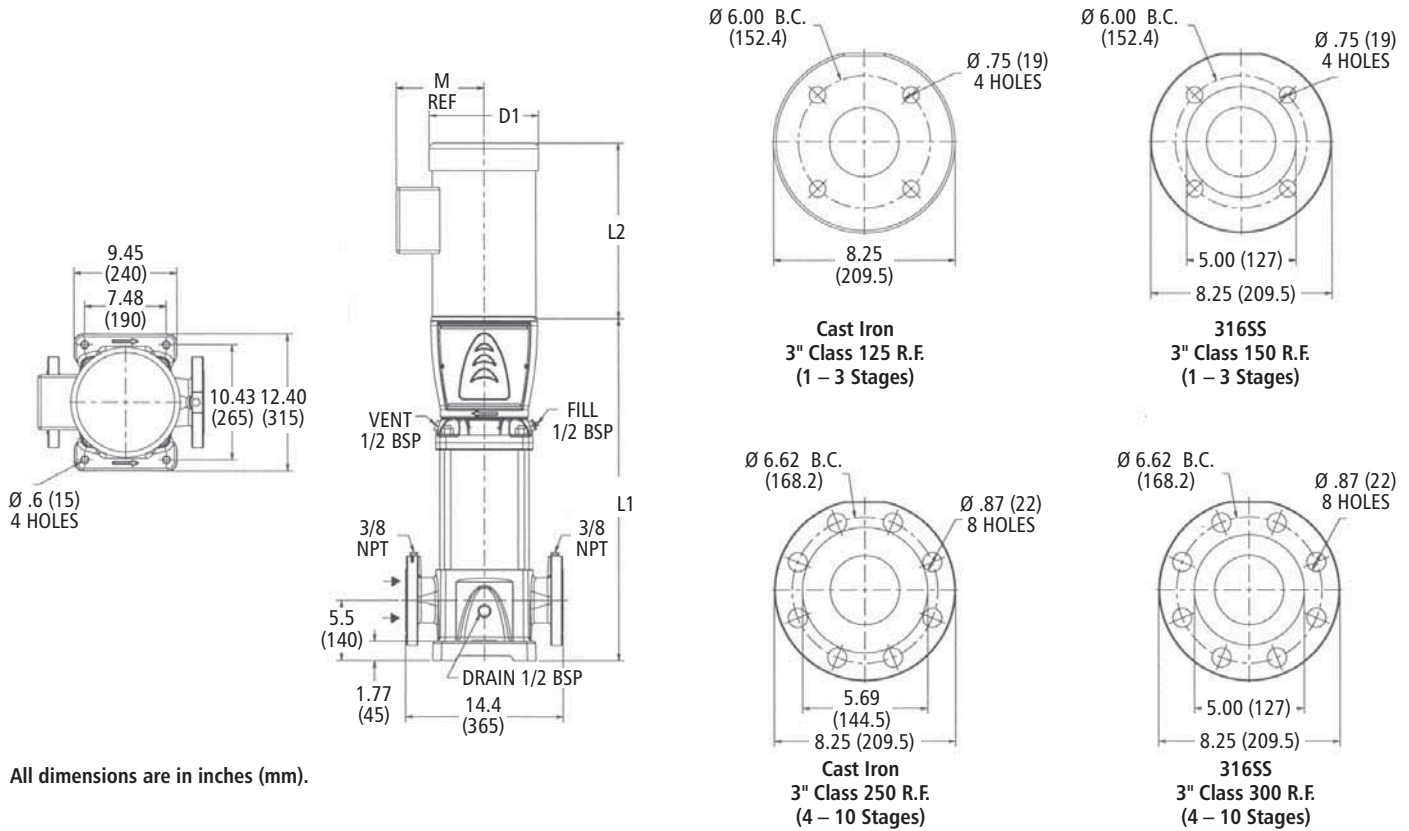

All dimensions are in inches (mm).

Stage	Frame (1-Phase)		Frame (3-Phase)		HP	L1	L2		M (ref.)	D1		Weights (lb)						
	ODP	TEFC	ODP	TEFC			ODP	TEFC		ODP	TEFC	Liquid End	ODP	TEFC				
1/1	213TC		182-4TC		7½	22.19	13.94	15.44	6.88	8.5	8.5	147	101	124				
1			213TC	215TC	10		15.5	8.06	10.25	130	151							
2/2	213TC		215TC	254TC	15	25.19	15.56	16.56	9.25	10.19	10.31	158	128	250				
2/1			254TC	256TC	20	28.12							169	220	280			
2			256TC	284TC	25	29.63							18	11.63	183	240	420	
3/2			284TC			30	32.63	20.12	23.38	13.12	13.25	15.31	192	325	445			
3/1														40	35.56	199	328	448
3														38.5	208			
4/2	38	216												382	592			
4/1	326TSC		50	38	40.94	22.5	27.22	14.96	19	233	242	474	736					
4														43.94	242	474	736	
5/2	326TSC	364TSC	60	43.94	46.88	24.12	27.22	14.96	19	253	500	762	264					
5/1														46.88	253	500	762	
5														49.81	264			
6/2														365TSC	75	46.88	24.12	27.22
6/1	365TSC		75	46.88	49.81	24.12	27.22	14.96	15.12	19	253	500	762					
6														49.81	264			
7/2														49.81	264			
7/1	365TSC		75	46.88	49.81	24.12	27.22	14.96	15.12	19	253	500	762					
7														49.81	264			
8/2	365TSC		75	46.88	49.81	24.12	27.22	14.96	15.12	19	253	500	762					
8/1														49.81	264			
8	365TSC		75	46.88	49.81	24.12	27.22	14.96	15.12	19	253	500	762					
9/2														49.81	264			
9/1	365TSC		75	46.88	49.81	24.12	27.22	14.96	15.12	19	253	500	762					
9														49.81	264			
10/2	365TSC		75	46.88	49.81	24.12	27.22	14.96	15.12	19	253	500	762					
10/1														49.81	264			

**46SV Curve 3500 RPM**

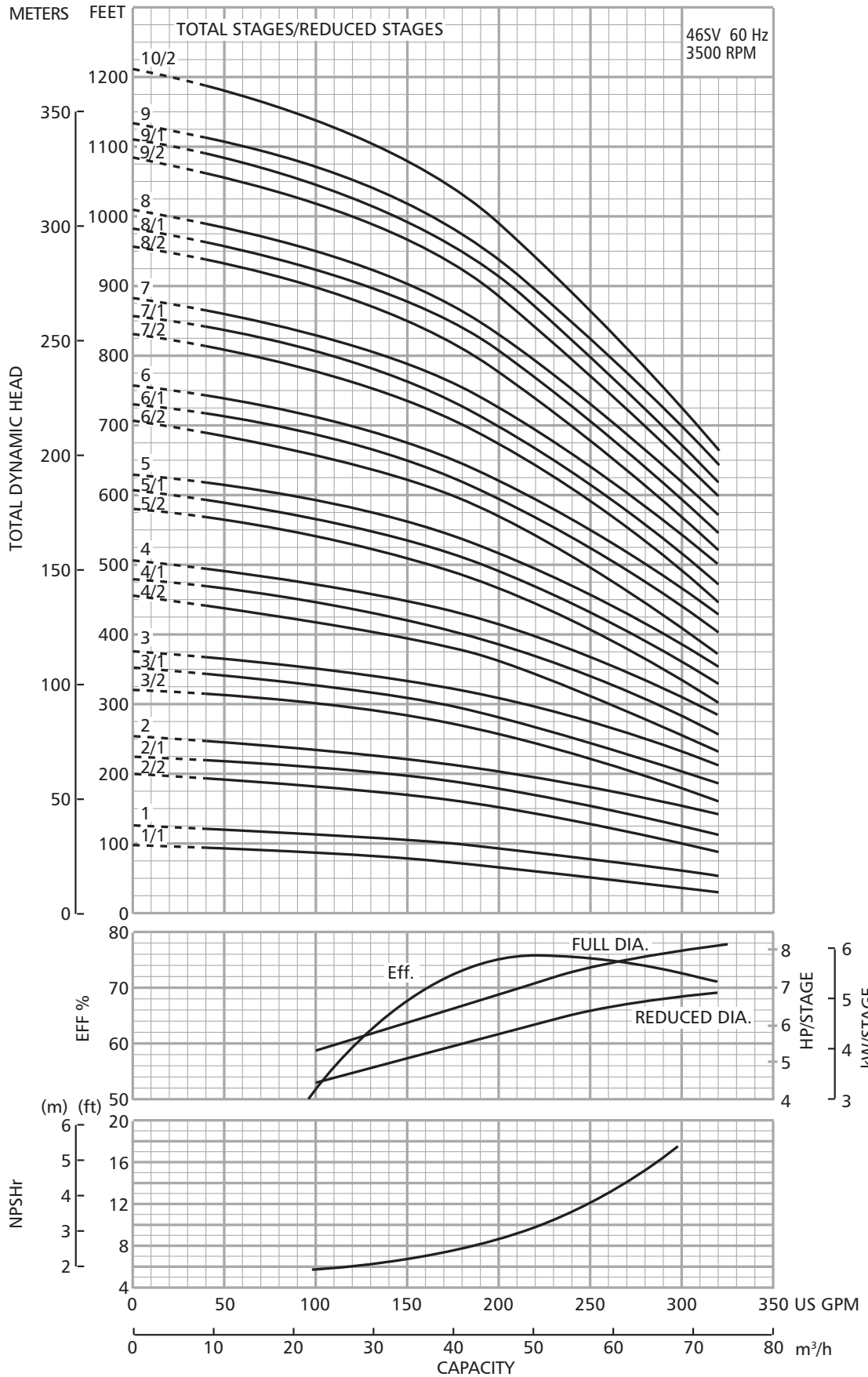

# Dimensions and Weights

## 66SV Series 3500 RPM

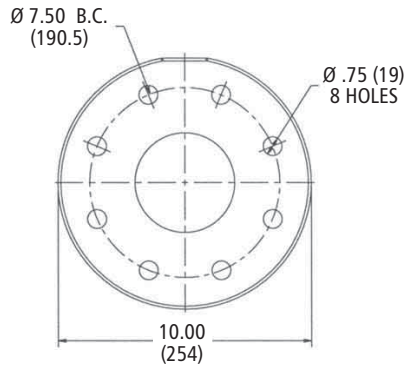
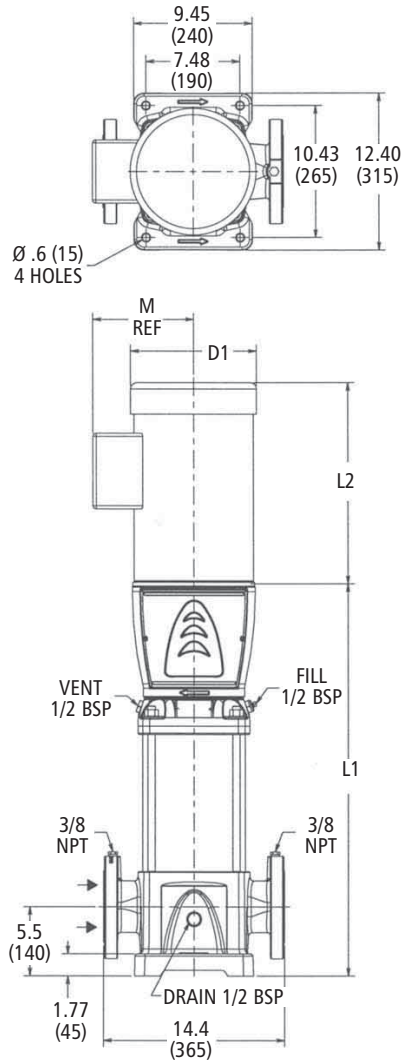

**Cast Iron**  
4" Class 125 R.F.  
(1 – 3 Stages)

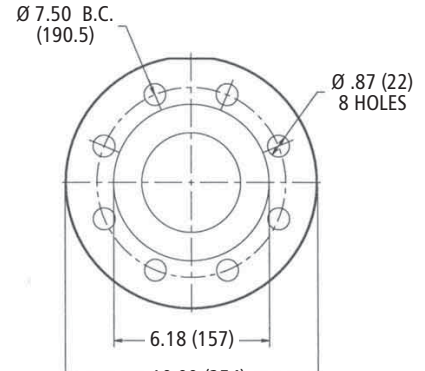

**316SS**  
4" Class 150 R.F.  
(1 – 3 Stages)

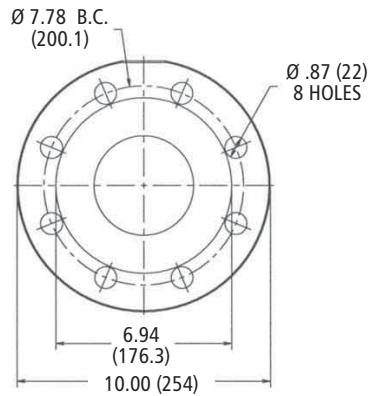

**Cast Iron**  
4" Class 250 R.F.  
(4 – 6 Stages)

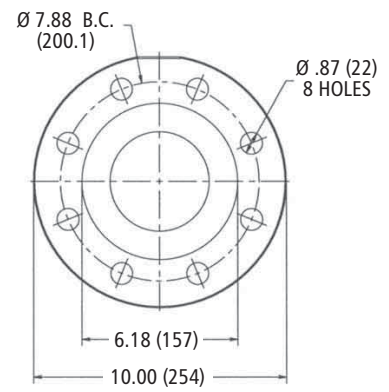

**316SS**  
4" Class 300 R.F.  
(4 – 6 Stages)

All dimensions are in inches (mm).

Stage	Frame (1-Phase)		Frame (3-Phase)		HP	L1	L2		M (ref.)	D1		Weights (lb)									
	ODP	TEFC	ODP	TEFC			ODP	TEFC		ODP	TEFC	Liquid End	ODP	TEFC							
1/1	213TC		213TC	215TC	10	23.19	15.56	15.5	8.06	10.19	10.25	185	130	151							
1			215TC	254TC	15								128	250							
2/2			254TC	256TC	20	26.75	23.38	13.12	13.25	15.31	196	220	280								
2/1					25	28.31						18	210	240	420						
3/2			284TC		30	31.81	20.12	23.38	13.12	15.31	223	325	445								
3/1					40							35.38	234	328	448						
3					326TSC		50	34.88	22.5	14.96	15.12	19	242	382	592						
4/2			60	38.44			252	474						736							
4/1			365TSC		75	41.94	24.12	27.22	14.96	15.12	19	266	500	762							
4													60	38.44	22.5	14.96	15.12	19	266	500	762
5/2																					
5/1					75	41.94	24.12	27.22	14.96	15.12	19	266	500	762							
5															326TSC	364TSC	60	38.44	22.5	14.96	15.12
6/2					75	41.94	24.12	27.22	14.96	15.12	19	266	500	762							
6/1															365TSC	75	41.94	24.12	27.22	14.96	15.12
6					75	41.94	24.12	27.22	14.96	15.12	19	266	500	762							
6															365TSC	75	41.94	24.12	27.22	14.96	15.12

66SV Curve 3500 RPM

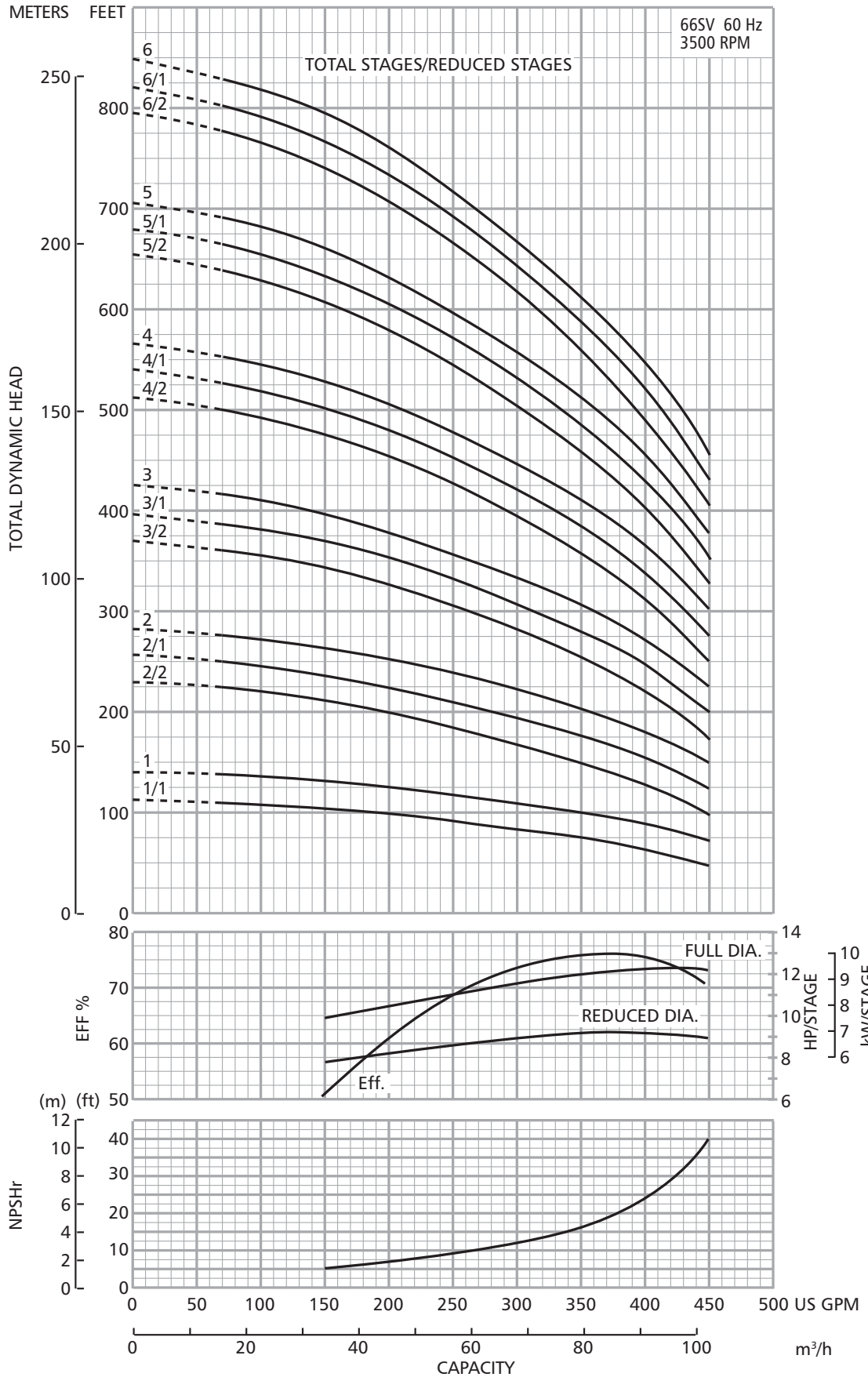

# Dimensions and Weights

## 92SV Series 3500 RPM

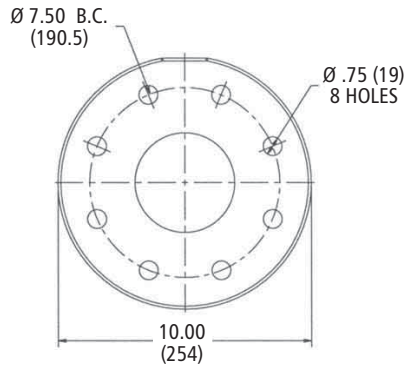
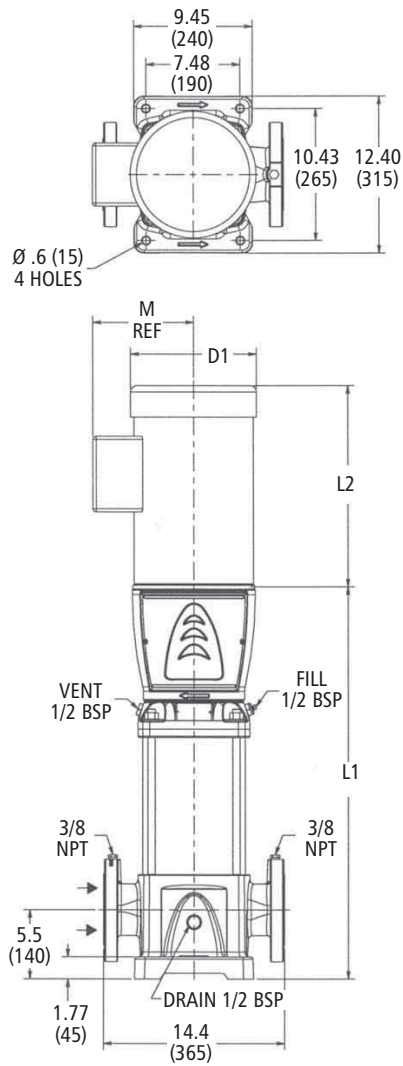

**Cast Iron**  
4" Class 125 R.F.  
(1 – 3 Stages)

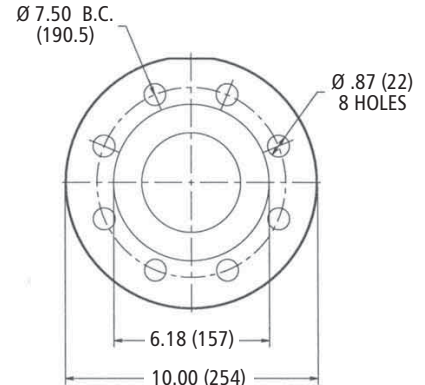

**316SS**  
4" Class 150 R.F.  
(1 – 3 Stages)

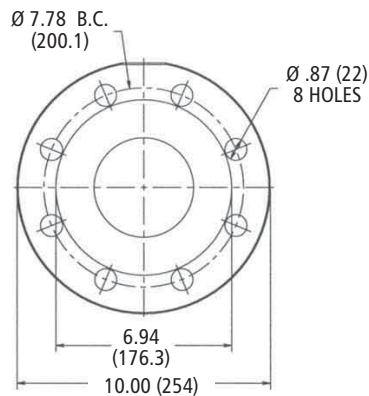

**Cast Iron**  
4" Class 250 R.F.  
(4 – 6 Stages)

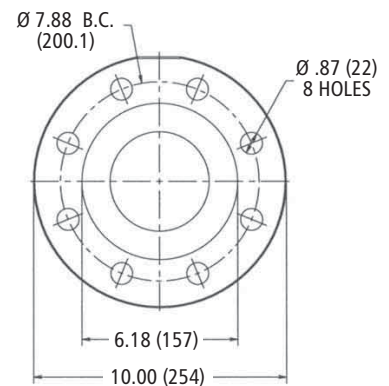

**316SS**  
4" Class 300 R.F.  
(4 – 6 Stages)

All dimensions are in inches (mm).

Stage	Frame (1-Phase)		Frame (3-Phase)		HP	L1	L2		M (ref.)	D1		Weights (lb)								
	ODP	TEFC	ODP	TEFC			ODP	TEFC		ODP	TEFC	Liquid End	ODP	TEFC						
1/1			215TC	254TC	15	23.19	15.56	16.56	9.25	10.19	10.31	185	128	250						
1			256TC	284TC	25	28.31	18	23.38	13.12	11.63	15.31	210	240	420						
2/2			284TC		30								325	445						
2/1					40	31.81	223	328	448											
2					50	31.28	231	382	592											
3/2			326TSC	364TSC	60	34.88	22.5	27.22	14.96	15.12	19	242	474	736						
3/1															75	38.44	24.12	252	500	762
3																				
4/2																				
4/1																				
4																				
5/2																				
5/1																				

# 92SV Curve 3500 RPM

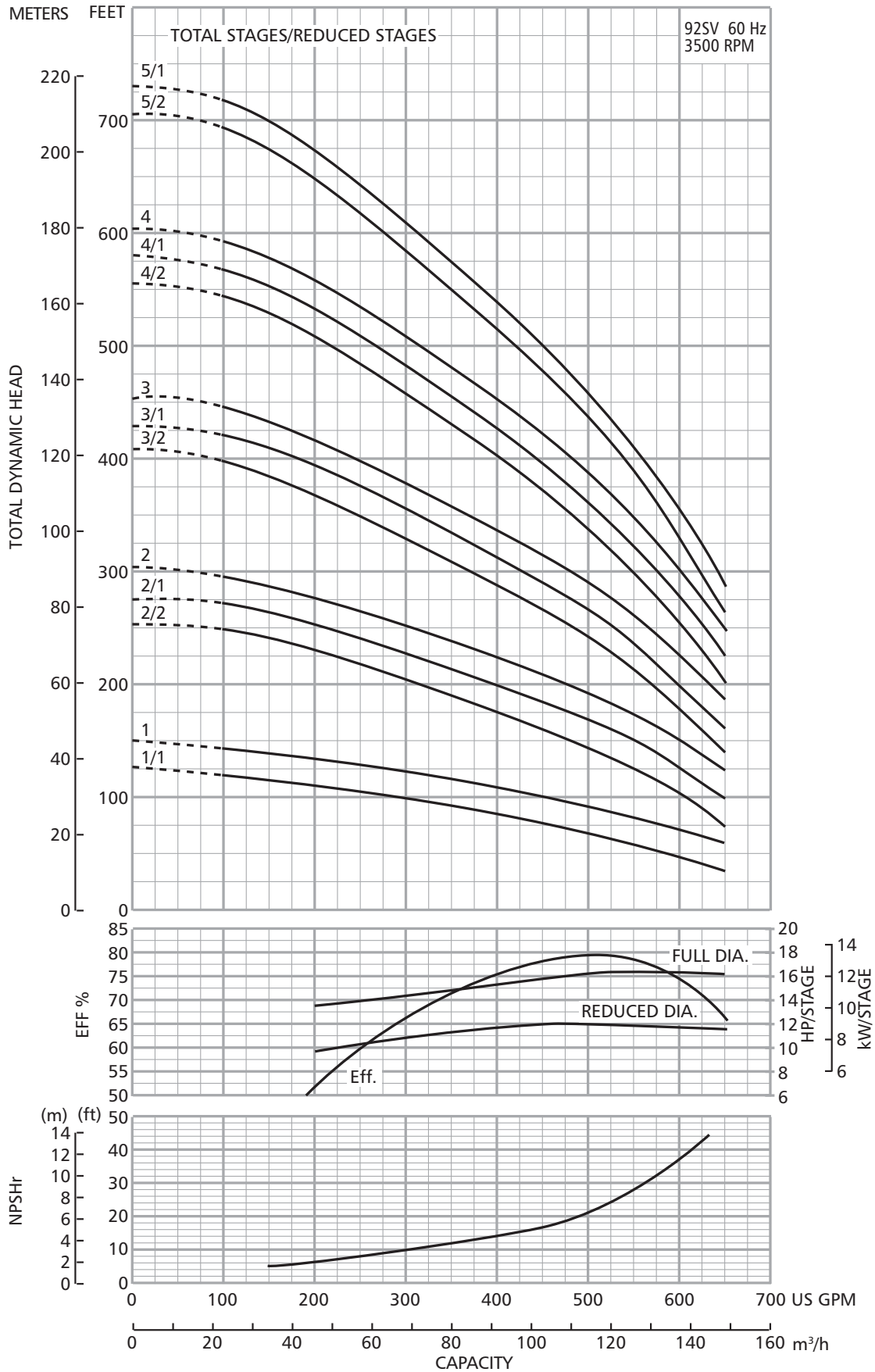

# Dimensions and Weights

## 1SV Series 2900 RPM

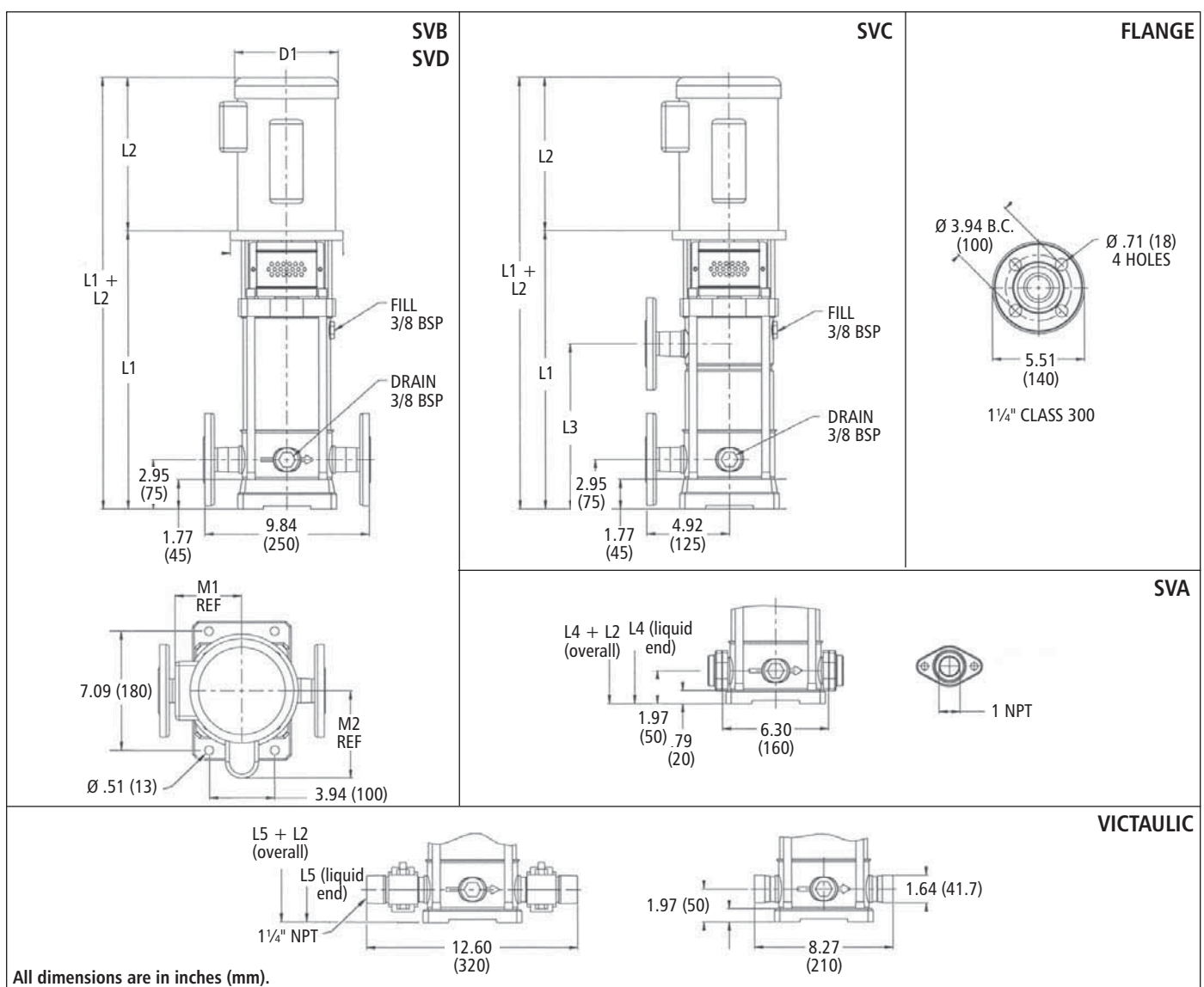

All dimensions are in inches (mm).

Stage	Frame (1-Phase)		Frame (3-Phase)				L2					D1 (max.)		Weights (lb)													
	ODP	TEFC	ODP	TEFC	HP	L1	ODP	TEFC	L3	L4	L5	M1 (ref.)	M2 (ref.)	ODP	TEFC	Liquid End	ODP	TEFC									
2	56C				1/2	12.69	10.75	9.94		11.69	11.69			6.19	6.19	21	24	28									
3						13.63										22											
4						14.63										23											
5					3/4	15.63	10.63	11.19		8.88	14.63					14.63	5.75	5.56	25	32	40						
6						16.63				27																	
7						17.63				28																	
8					1 1/2	18.56	11.19	12.06		11.81	17.56					17.56	7.19	7.19	29	43	51						
9						19.56				30																	
11						20.50				33																	
12					2	21.50	11.56	13.44		14.75	21.50					21.50	8.50	8.50	34	51	56						
14						23.50				36																	
16						26.44				39																	
18					182-4TC					3	28.44					13.94	15.44			27.50	6.88	6.63	8.50	8.50	41	75	85
20											30.44									44							
22	32.44	46																									
24	34.44	48																									

# 1SV Curve 2900 RPM

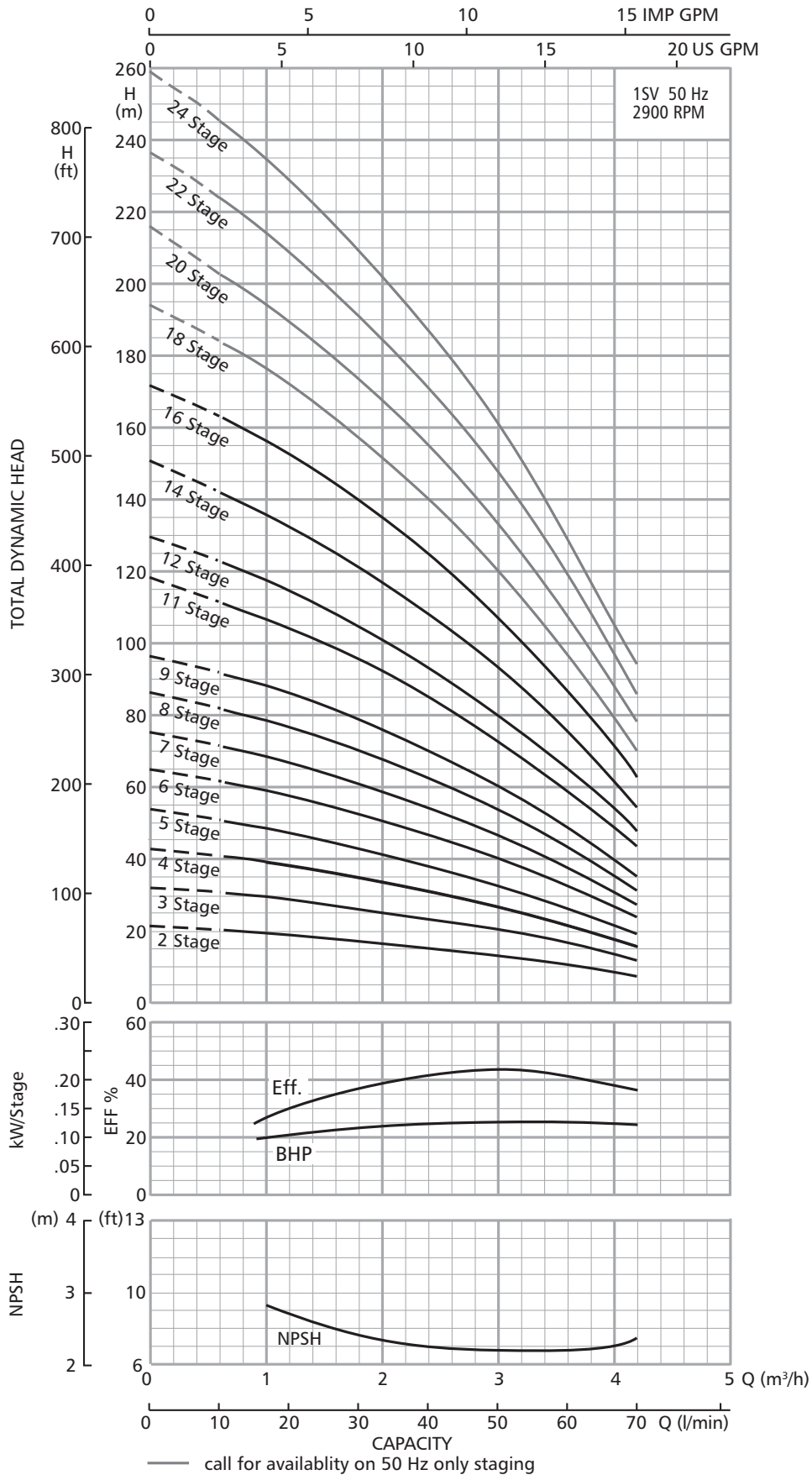

# Dimensions and Weights

## 2SV Series 2900 RPM

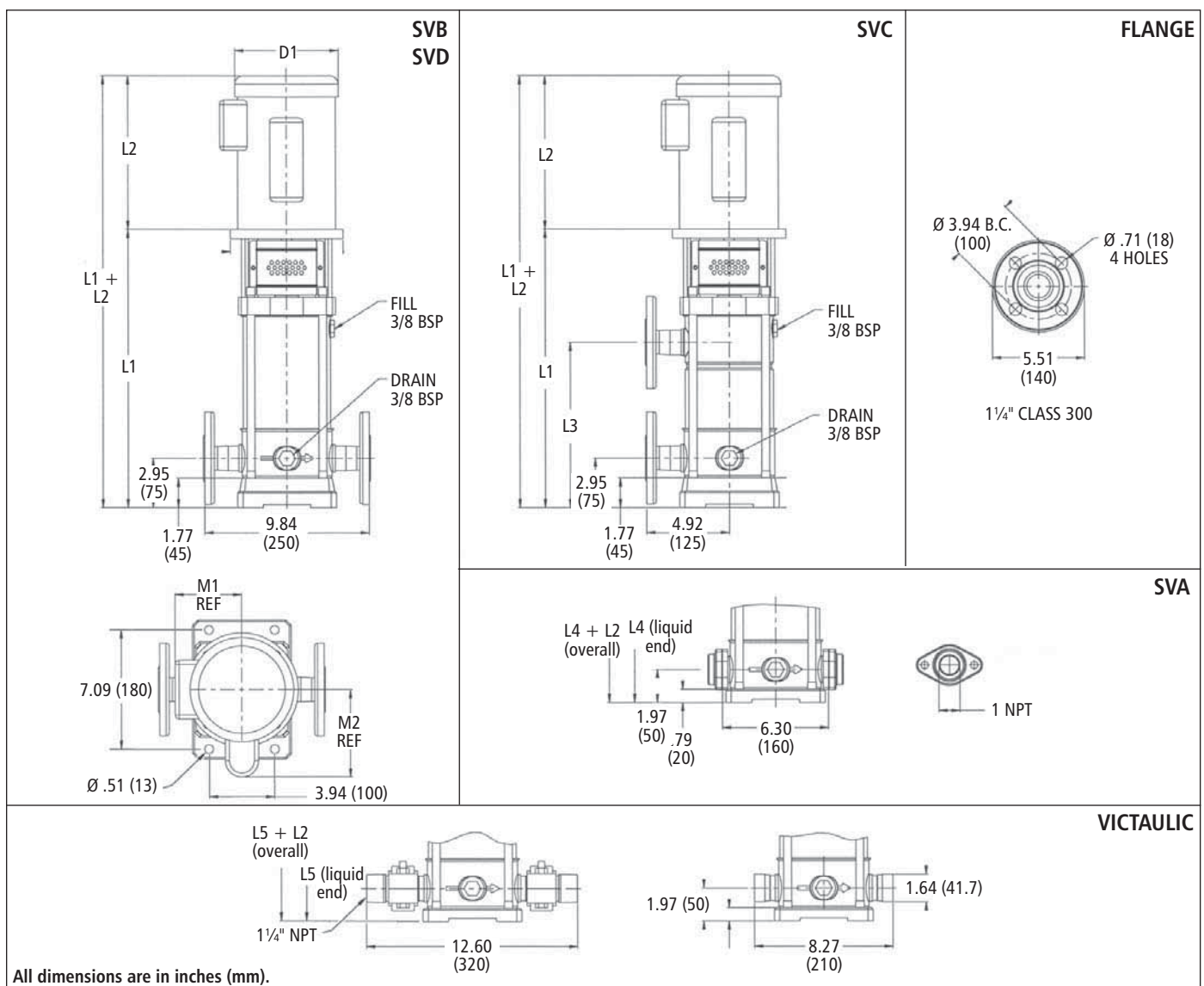

All dimensions are in inches (mm).

Stage	Frame (1-Phase)		Frame (3-Phase)				L2					D1 (max.)		Weights (lb)														
	ODP	TEFC	ODP	TEFC	HP	L1	ODP	TEFC	L3	L4	L5	M1 (ref.)	M2 (ref.)	ODP	TEFC	Liquid End	ODP	TEFC										
2	56C		56C		1/2	12.69	10.75	9.94		11.69	11.69	5.06	5.19	6.19		21	24	28										
3						13.63										22												
4					3/4	14.63	10.63	11.19		8.88	14.63	14.63	5.75			5.56	7.19	24	32	40								
5					1	15.63												25										
6					16.63	26	11.19	12.06		10.81	16.63	16.63	7.19			28	43	51										
7					1 1/2	17.56										30												
8					18.56	31	11.56	13.44		12.81	18.56	18.56	7.19			31	51	56										
9					2	19.56										33												
11					21.50	35	182-4TC			3	23.50	13.94	15.44			16.75	22.50	22.50	6.88	6.63	8.50	8.50	35	75	85			
13					24.50	37																						
14					26.44	40																						
16	28.44	42																										
18	30.44	44																										
20	32.44	46	213TC	5	32.44	33.50			31.50		6.88			6.63	8.50								8.50			46	101	124
22	34.44	50																										
24																												

# 2SV Curve 2900 RPM

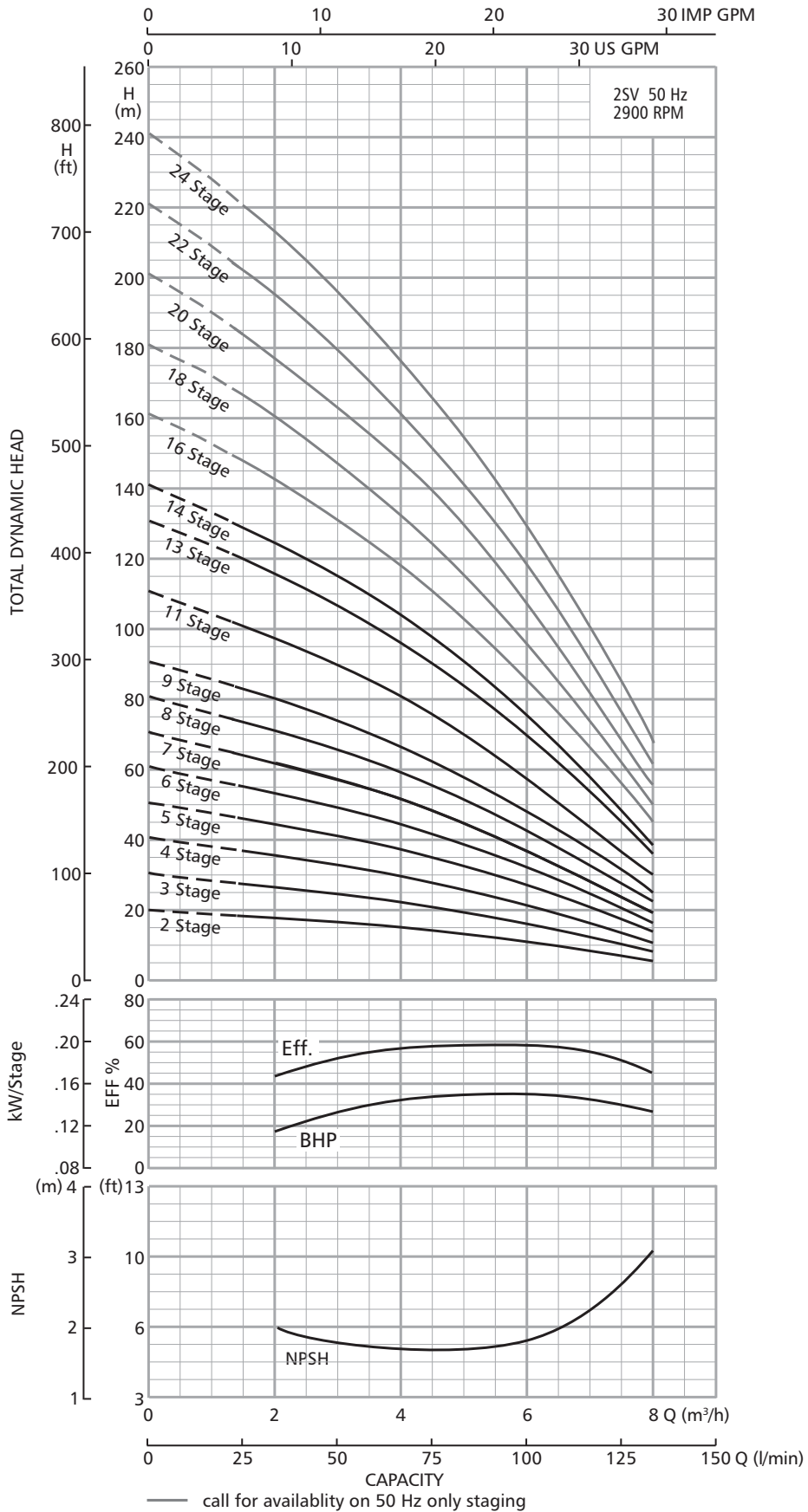

# Dimensions and Weights 3SV Series 2900 RPM

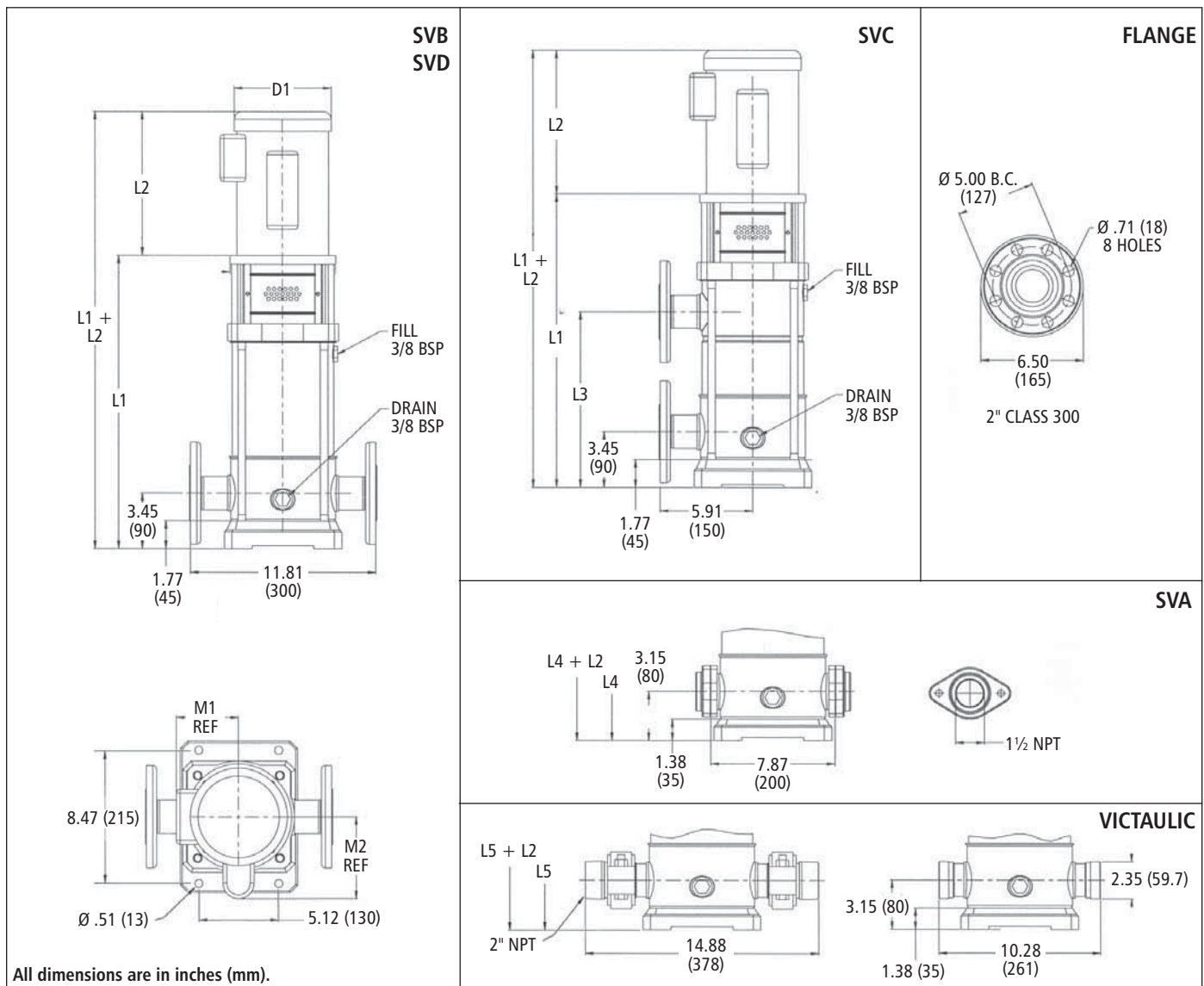

Stage	Frame (1-Phase)		Frame (3-Phase)				L2					M1 (ref.)		M2 (ref.)		D1 (max.)		Weights (lb)		
	ODP	TEFC	ODP	TEFC	HP	L1	ODP	TEFC	L3	L4	L5			ODP	TEFC	Liquid End	ODP	TEFC		
2	56C		56C		1½	15.31	11.19	12.06		15.31	15.31	5.75	5.56	7.19	7.19	33	43	51		
3						16.81				16.81	35									
4						18.31				18.31	37									
5	184TC		184TC		2	18.31	11.56	13.44		18.31	18.31					40	75	85		
6	213TC		184TC		3	19.81	13.94	15.44		12.69	19.81	19.81	6.88	6.63	8.50	8.50	44	101	124	
8						22.81				17.19	24.25	24.25					45			
9						24.25				20.19	25.38	25.38					47			
11	213TC	213TC	215TC	7½	28.38	15.56	15.50			21.69	28.38	28.38	8.06	8.77	10.19	10.25	62	130	151	
12					29.88					24.63	29.38	64								
14					32.88						32.88	68								
16			215TC	254TC	10	35.88	16.56			35.88		9.25		10.31	72	128	250			

# 3SV Curve 2900 RPM

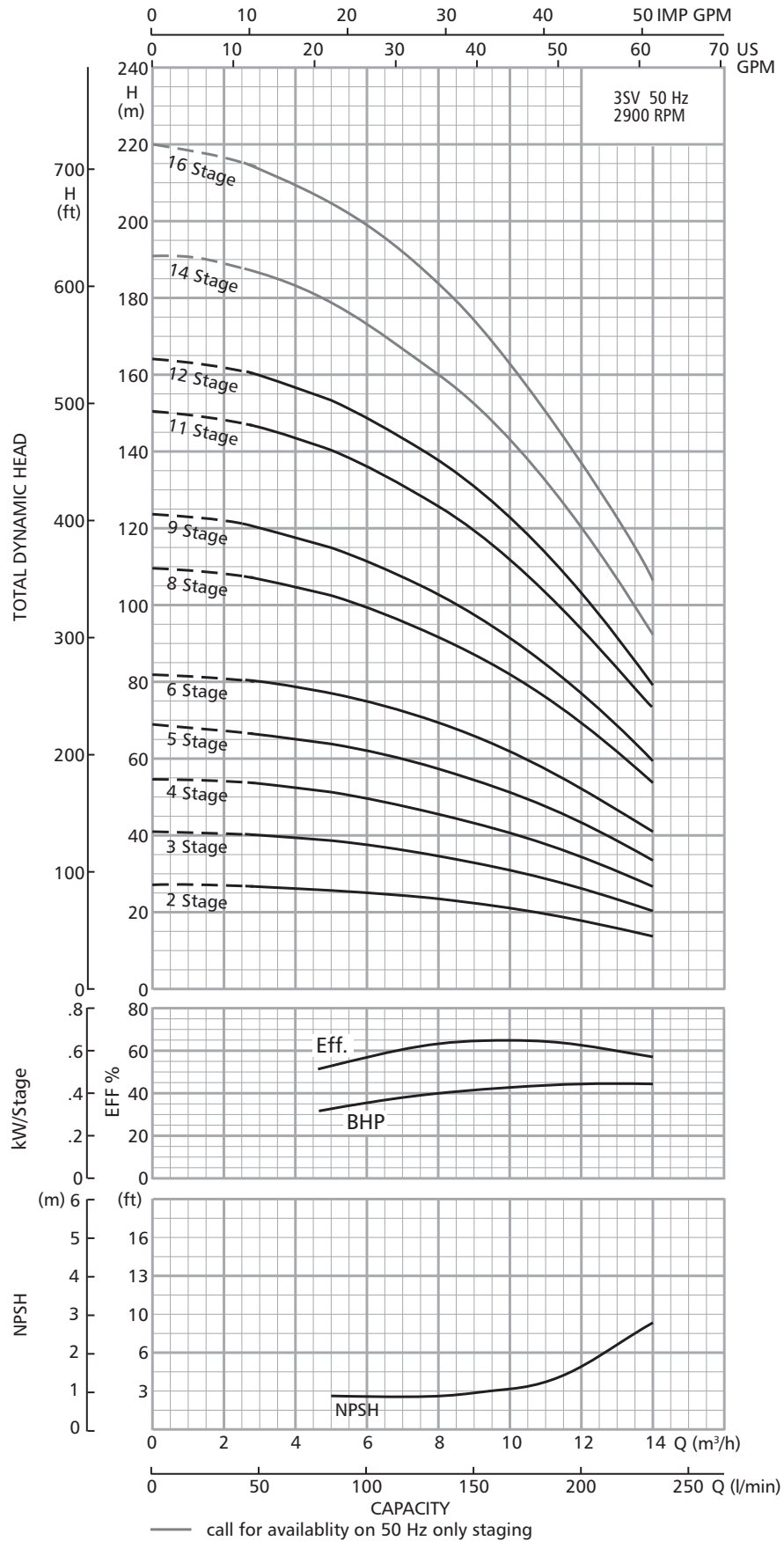

# Dimensions and Weights

## 4SV Series 2900 RPM

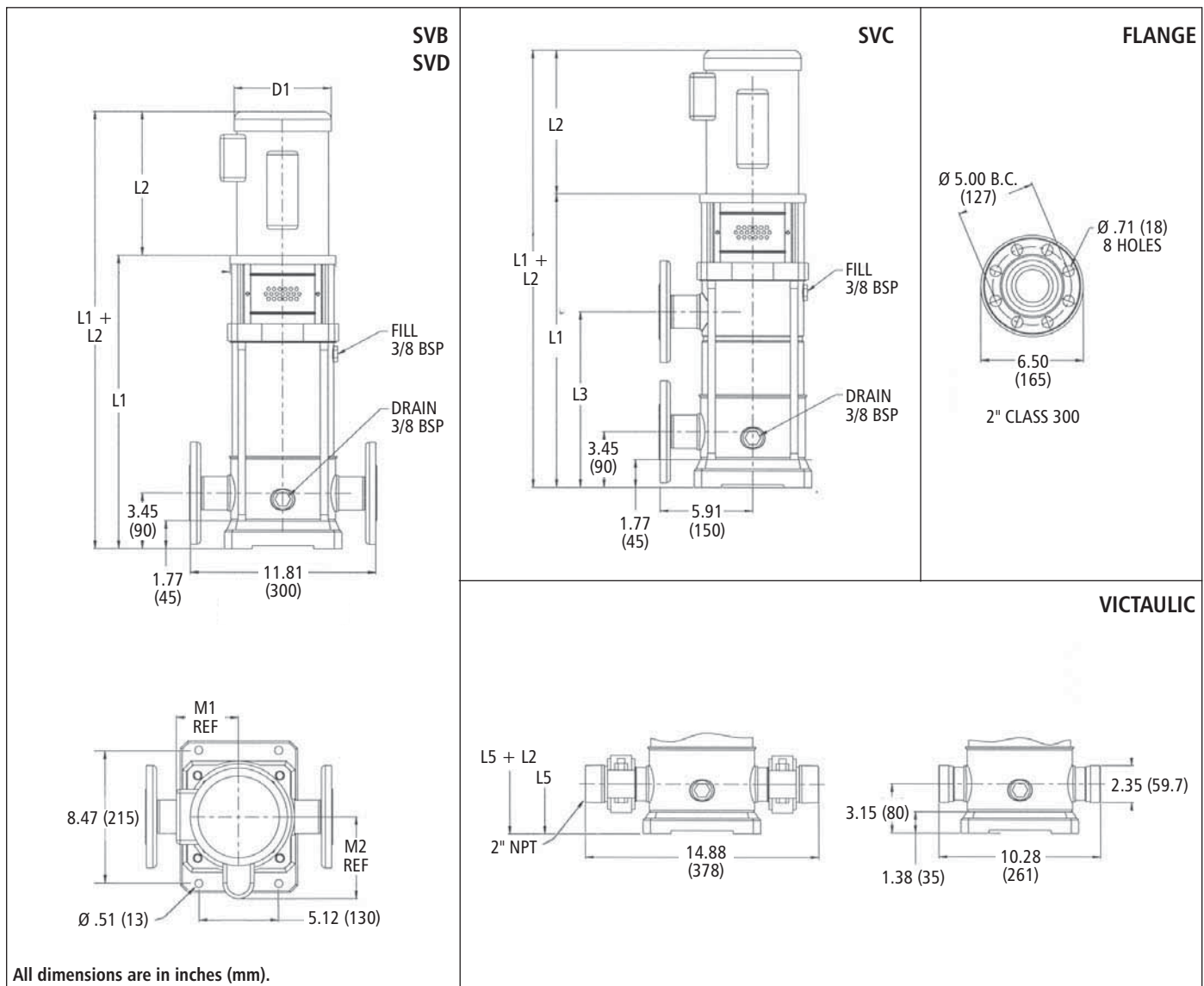

Stage	Frame (1-Phase)		Frame (3-Phase)		HP	L1	L2		L3	L5	M1 (ref.)	M2 (ref.)	D1 (max.)		Weights (lb)		
	ODP	TEFC	ODP	TEFC			ODP	TEFC					L3	L5	ODP	TEFC	Liquid End
3	182-4TC		182-4TC		3	17.25	13.94	15.44		17.25	6.88	6.63	8.50	8.50	35	75	85
4					5	18.75			11.19	18.75					39	101	124
5						21.44			12.69	21.44					48		
6	213TC		213TC	215TC	7½	24.44		15.50	15.69	24.44	8.06	8.77		10.25	50	130	151
7															52		
8			215TC	254TC	10	25.94	15.56		17.19	25.94			10.19		55	128	250
10						28.88		16.56	20.19	28.88	9.25				75		
12			254TC	256TC	15	31.88				31.88				10.31	79	220	280
14						34.88				34.88					84		
15			256TC	284TC	20	36.75	18.00	23.38		36.75	13.13		11.63		86	240	420

# 4SV Curve 2900 RPM

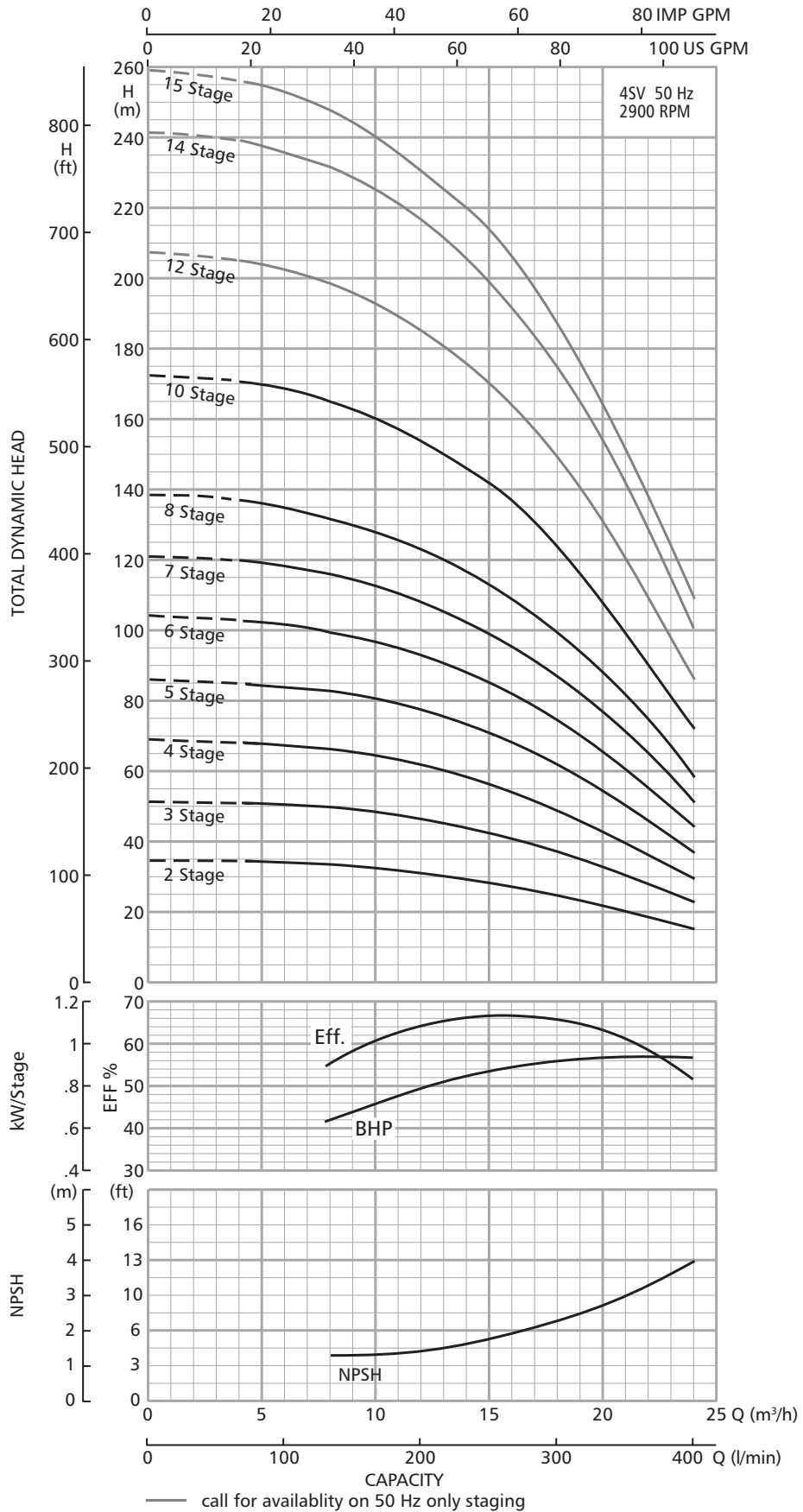

# Dimensions and Weights

## 33SV Series 2900 RPM

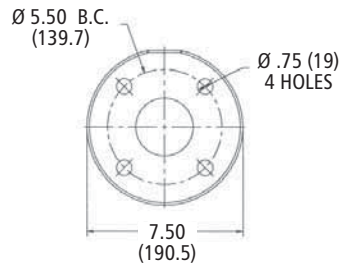
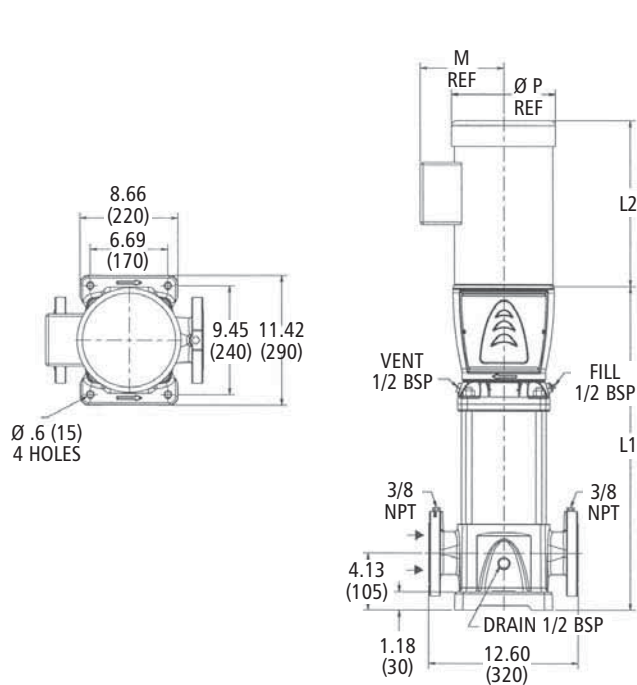

**Cast Iron**  
2 1/2" Class 125 R.F.  
(1 – 4 Stages)

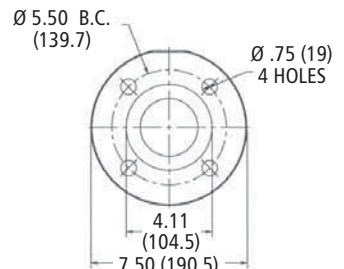

**316SS**  
2 1/2" Class 150 R.F.  
(1 – 4 Stages)

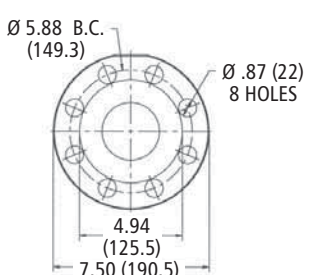

**Cast Iron**  
2 1/2" Class 250 R.F.  
(5 – 10 Stages)

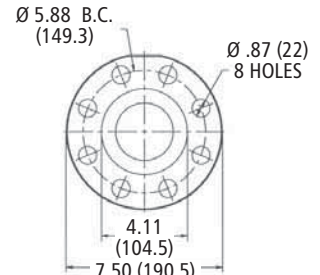

**316SS**  
2 1/2" Class 300 R.F.  
(5 – 10 Stages)

All dimensions are in inches (mm).

Stage	Frame (1-Phase)		Frame (3-Phase)		HP	L1	L2		M (ref.)	D1		Weights (lb)		
	ODP	TEFC	ODP	TEFC			ODP	TEFC		ODP	TEFC	Liquid End	ODP	TEFC
1/1	182-4TC		182-4TC		2	20.62	13.94	15.44	6.88	8.5	8.5	132	75	85
1					3									
2/2					5									
2/1	213TC		213TC	215TC	7 1/2	23.58	15.5	8.06	10.25	152	130	151		
2					29.50									
3/2					215TC								254TC	10
3/1	254TC		256TC	256TC	15	32.44	16.56	9.25	10.31	172	220	280		
3					35.40									
4/2					256TC								284TC	20
4/1	284TC		284TC	284TC	25	38.35	23.38	13.12	15.31	204	240	420		
4					41.30									
5/2					25								44.25	20.12
5/1	284TC		284TC	284TC	30	47.20	20.12	13.25	15.31	230	325	445		
5					44.25									
6/2					30								47.20	20.12
6/1	284TC		284TC	284TC	30	47.20	20.12	13.25	15.31	249	382	592		
6					47.20									
7/2					30								47.20	20.12
7/1	284TC		284TC	284TC	30	47.20	20.12	13.25	15.31	249	382	592		
7					47.20									
8/2					30								47.20	20.12
8/1	284TC		284TC	284TC	30	47.20	20.12	13.25	15.31	249	382	592		
8					47.20									
9/2					30								47.20	20.12
9/1	284TC		284TC	284TC	30	47.20	20.12	13.25	15.31	249	382	592		
9					47.20									
10/2					30								47.20	20.12
10/1	284TC		284TC	284TC	30	47.20	20.12	13.25	15.31	249	382	592		
10					47.20									

# 33SV Curve 2900 RPM

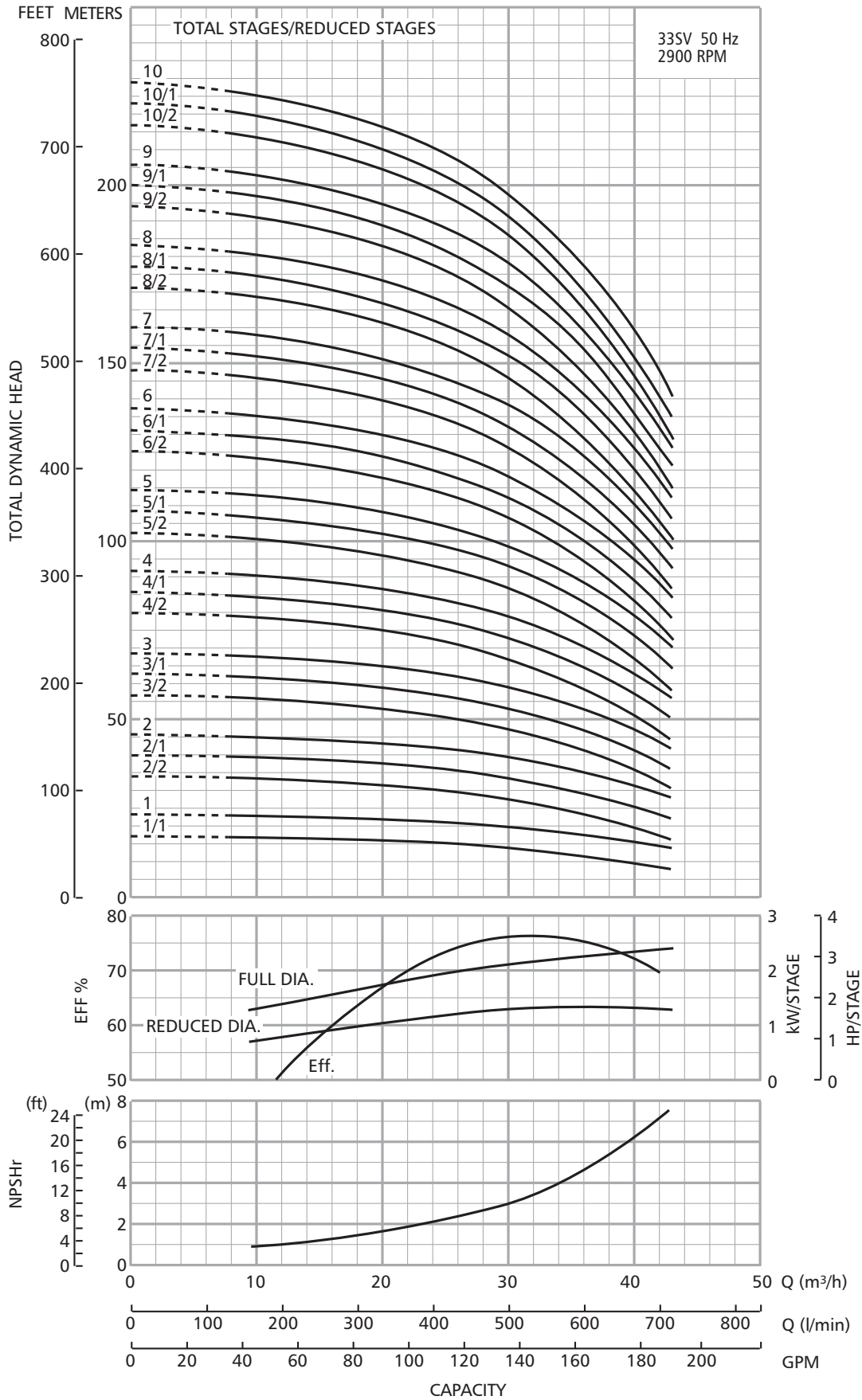

# Dimensions and Weights

## 46SV Series 2900 RPM

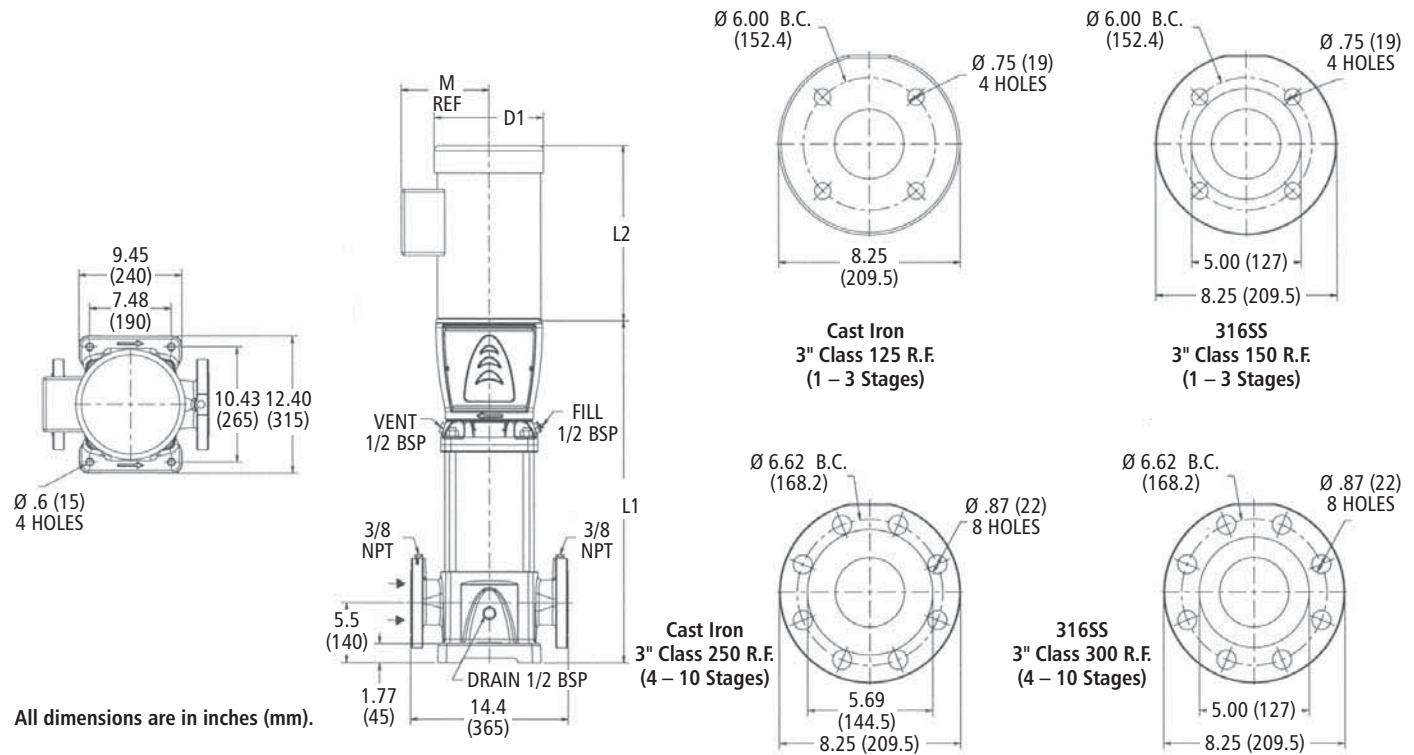

Stage	Frame (1-Phase)		Frame (3-Phase)		HP	L1	L2		M (ref.)	D1		Weights (lb)		
	ODP	TEFC	ODP	TEFC			ODP	TEFC		ODP	TEFC	Liquid End	ODP	TEFC
1/1	182-4TC		182-4TC		5	22.19	13.94	15.44	6.88	8.5	8.5	147	101	124
1														
2/2														
2/1	213TC		213TC	215TC	7½	25.19	15.56	16.56	9.25	10.19	10.25	158	130	151
2	215TC	254TC	10	28.12										
3/2														
3/1														
3	254TC	256TC	15	32.63	18	20.12	23.38	13.12	10.31	15.31	169	220	280	
4/2														
4/1														
4	256TC	284TC	20	35.56	18	20.12	23.38	13.12	15.31	15.31	185	220	280	
5/2														
5/1														
5	284TC	284TC	25	38.5	20.12	23.38	13.12	15.31	15.31	15.31	208	325	445	
6/2														
6/1														
6	284TC	284TC	30	40.94	20.12	23.38	13.12	15.31	15.31	15.31	225	328	448	
7/2														
7/1														
7	326TSC	326TSC	40	43.94	22.5	22.5	22.5	22.5	22.5	22.5	234	382	592	
8/2														
8/1														
8	326TSC	326TSC	40	46.88	22.5	22.5	22.5	22.5	22.5	22.5	253	382	592	
9/2														
9/1														
9	326TSC	326TSC	40	49.81	22.5	22.5	22.5	22.5	22.5	22.5	264	382	592	
10/2														
10/1														
10														

# 46SV Curve 2900 RPM

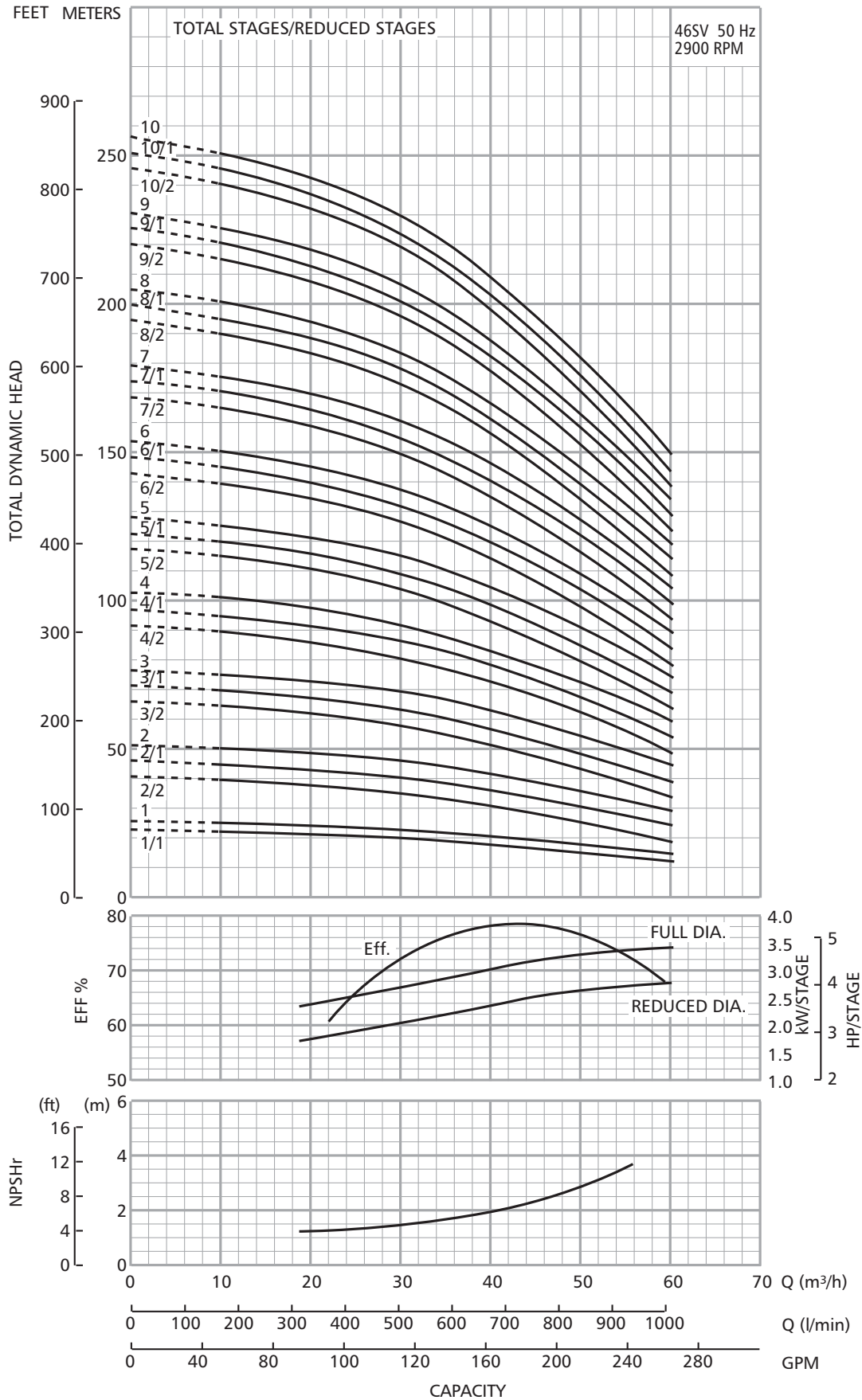

# Dimensions and Weights

## 66SV Series 2900 RPM

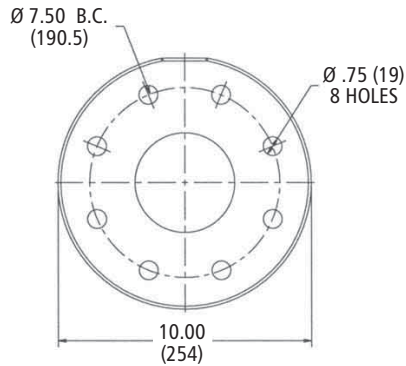
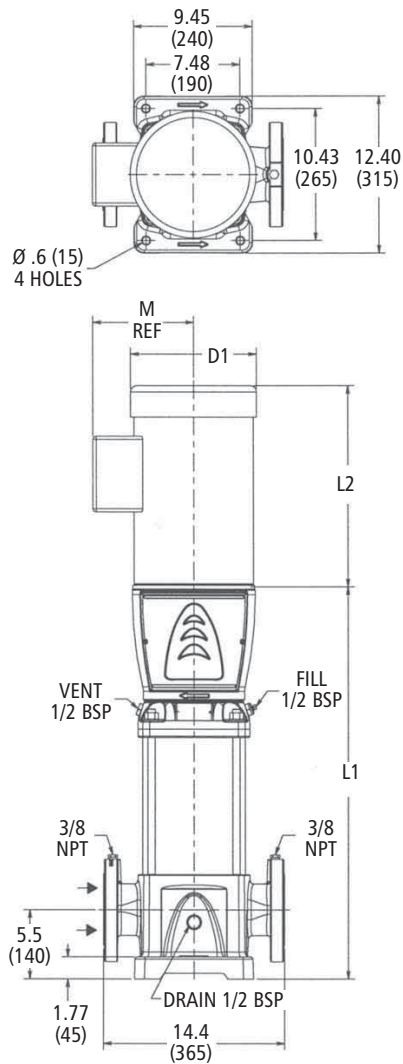

**Cast Iron**  
4" Class 125 R.F.  
(1 – 3 Stages)

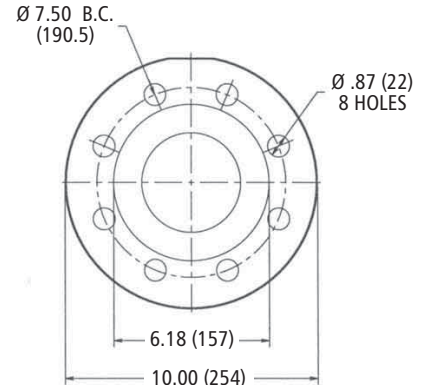

**316SS**  
4" Class 150 R.F.  
(1 – 3 Stages)

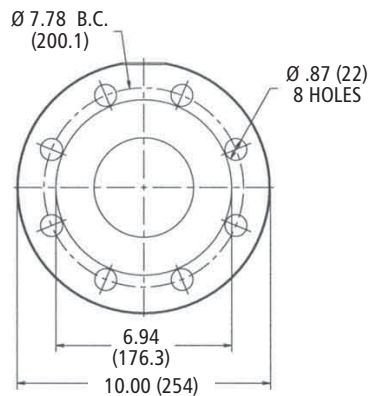

**Cast Iron**  
4" Class 250 R.F.  
(4 – 6 Stages)

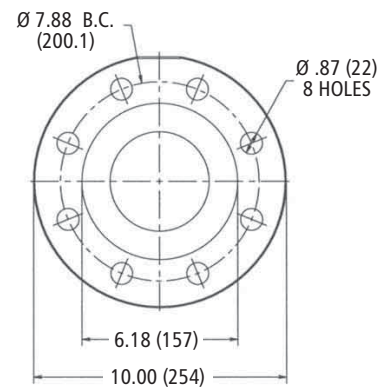

**316SS**  
4" Class 300 R.F.  
(4 – 6 Stages)

All dimensions are in inches (mm).

Stage	Frame (1-Phase)		Frame (3-Phase)		HP	L1	L2		M (ref.)	D1		Weights (lb)		
	ODP	TEFC	ODP	TEFC			ODP	TEFC		ODP	TEFC	Liquid End	ODP	TEFC
1/1	182-84TC		182-84TC		5	23.19	13.94	15.44	6.88	8.5	8.5	185	101	124
1	213TC		213TC	215TC	7.5		15.5	8.06		10.25			130	151
2/2			215TC	254TC	10	26.75	15.6	16.56	9.25	10.19	10.31	196	128	250
2/1			254TC	256TC	15								220	280
3/2			256TC	284TC	20	31.81	18			11.63		223	240	420
3/1													240	420
4/2			284TC		25	35.38	20.12	23.38	13.12	13.25	15.31	234	325	445
4/1													325	445
4													328	448
5/2													244	448
5/1			326TSC		40	41.94	22.5					266	382	592
5													382	592
6/2													382	592
6/1														
6														

# 66SV Curve 2900 RPM

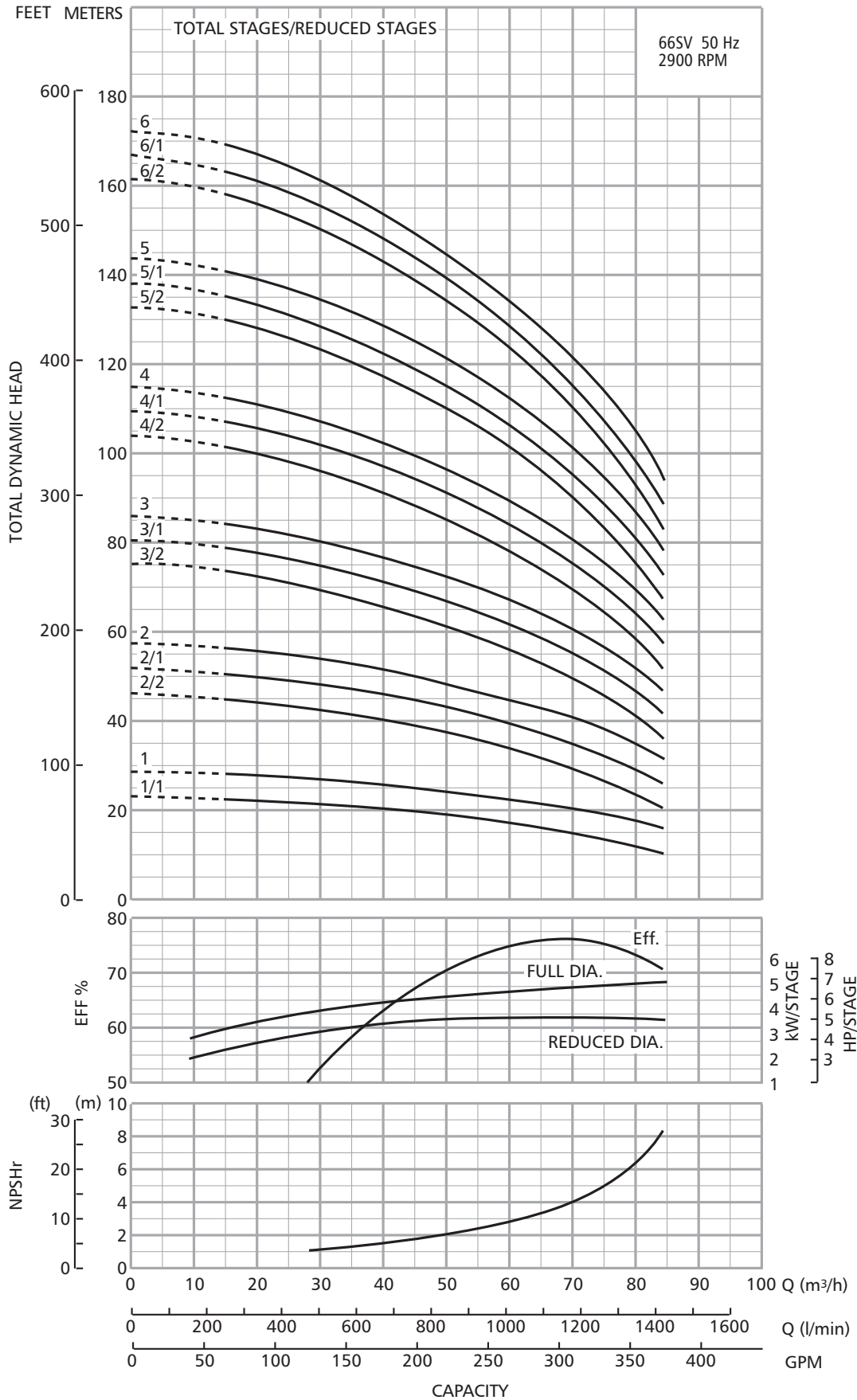

# Dimensions and Weights

## 92SV Series 2900 RPM

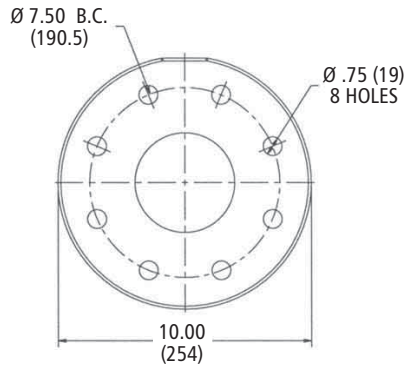
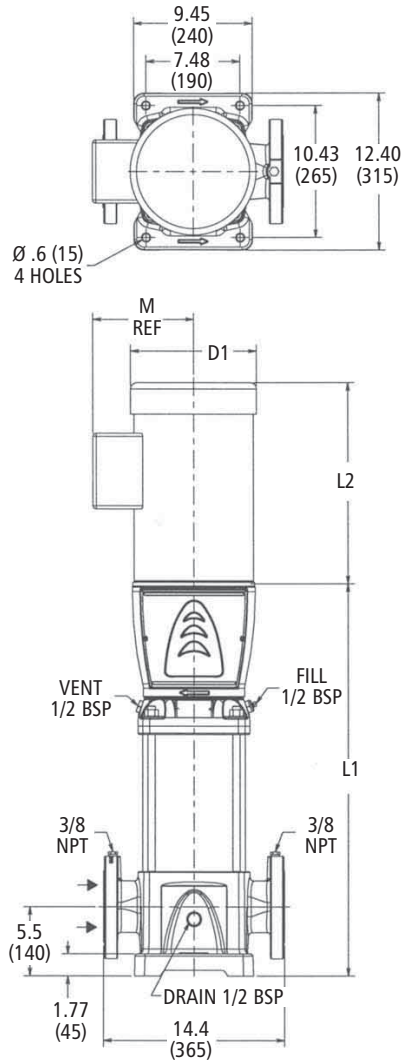

**Cast Iron**  
4" Class 125 R.F.  
(1 – 3 Stages)

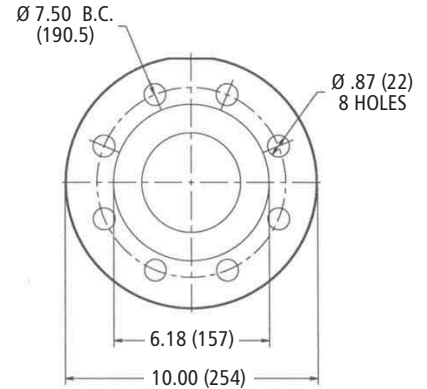

**316SS**  
4" Class 150 R.F.  
(1 – 3 Stages)

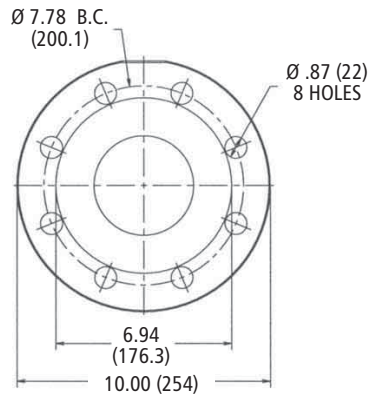

**Cast Iron**  
4" Class 250 R.F.  
(4 – 6 Stages)

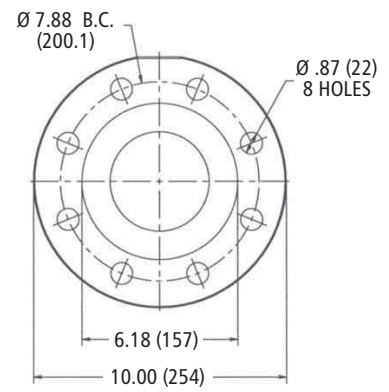

**316SS**  
4" Class 300 R.F.  
(4 – 6 Stages)

All dimensions are in inches (mm).

Stage	Frame (1-Phase)		Frame (3-Phase)		HP	L1	L2		M (ref.)	D1		Weights (lb)		
	ODP	TEFC	ODP	TEFC			ODP	TEFC		ODP	TEFC	Liquid End	ODP	TEFC
1/1	213TC		213TC		7.5	23.19	15.5	8.06	10.19	10.25	185	130	151	
1			215TC	254TC	10							128	250	
2/2			254TC	256TC	15	26.75	16.56	9.25	10.31	210	220	280		
2/1			256TC	284TC	20						240	420		
2			284TC		25	31.81	18	11.63	15.31	223	325	445		
3/2					30						20.12	23.38	242	328
3/1					40	34.88	20.12	23.38	13.12	15.31	242	328	448	
3					30							20.12	23.38	242
4/2					40	38.44	22.5	13.12	13.25	252	382	592		
4/1					40						38.44	22.5	13.25	252
4					50	41.94	22.5	27.22	19	266	500	762		
5/2			326TSC	364TSC	50						41.94	27.22	19	266
5/1					50	41.94	27.22	19	266	500	762			
5					50	41.94	27.22	19	266	500	762			
6/2					50	41.94	27.22	19	266	500	762			
6/1					50	41.94	27.22	19	266	500	762			
6					50	41.94	27.22	19	266	500	762			

# 92SV Curve 2900 RPM

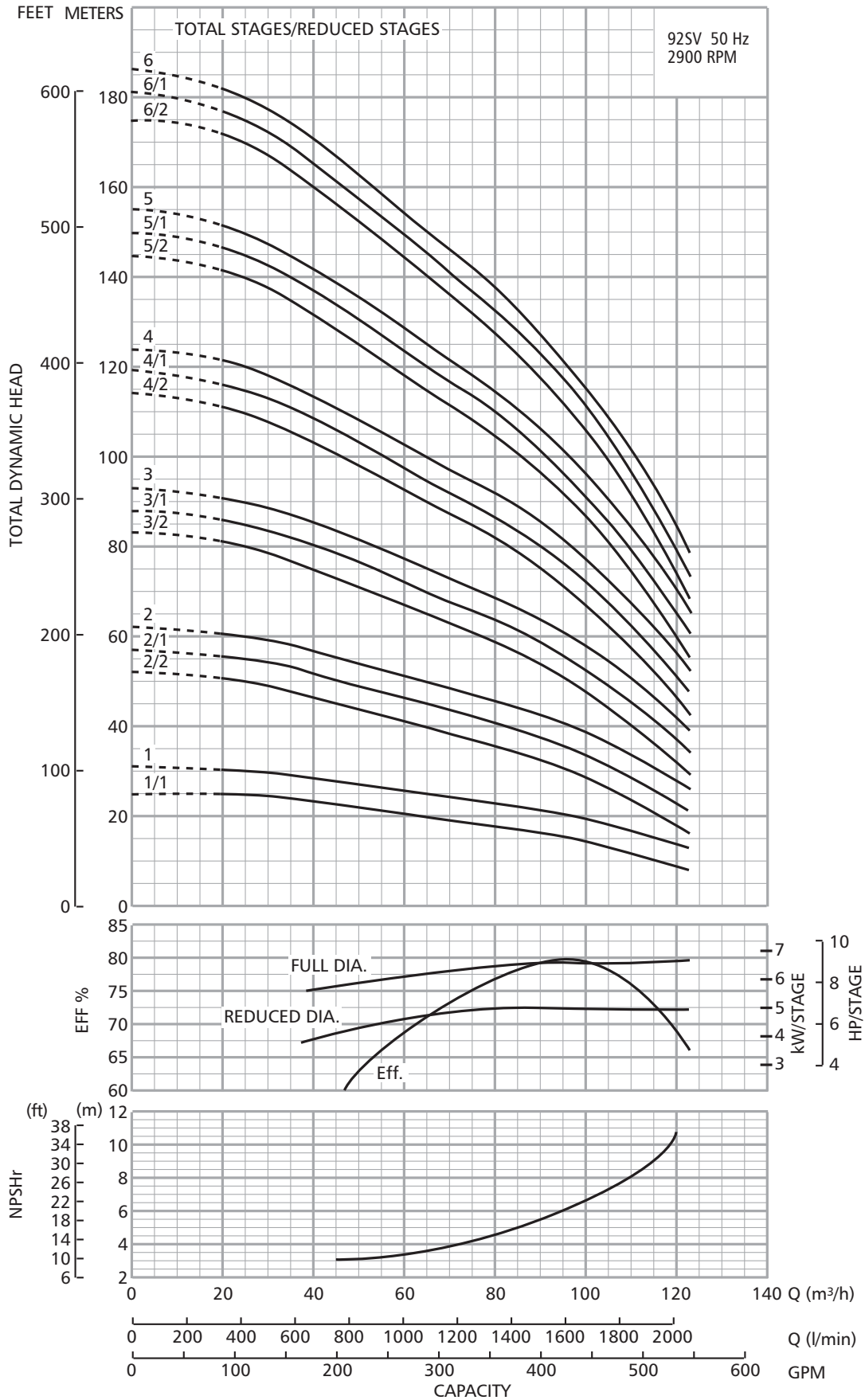

---

## Round Mating Flanges

---

Standard supply (included with pump)

- 1SV, 2SV and 3SV (SVA);

On request

- 1SV, 2SV and 3SV (versions SVB, SVC, SVD) oval flanges, threaded: kit containing 2 threaded mating flanges made of AISI 316 stainless steel plus hardware and gaskets.
- SV33, 46, 66, 92 (SVB version): kit containing mating flanges (class 150 and class 300) threaded made of carbon steel. Each kit contains 2 mating flanges plus hardware and gaskets.
- SV33, 46, 66, 92 (SVD versions): kit containing mating flanges (class 150 and class 300) threaded made of AISI 316 stainless steel. Each kit contains 2 mating flanges plus hardware and gaskets.

### **Victaulic® Accessories (on request)**

- 1, 2, 3 and 4SV version: kit containing 1 Victaulic® coupling with AISI 316L stainless steel weld-on or threaded sleeve, plus EPDM or viton o-ring gasket.

## Horizontal Mounting Option

- Available for all SSV sizes and all of their configurations.
- Consists of SSV pump with base mounting foot and footed motor for horizontal installations.
- Unit depicted may not show actual pump configuration. Use for mounting location only.

**Not available  
less motor.**

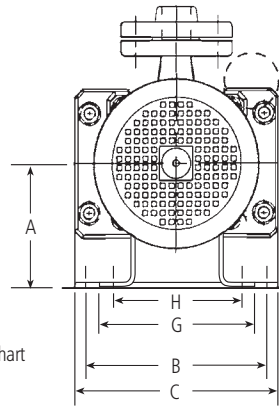
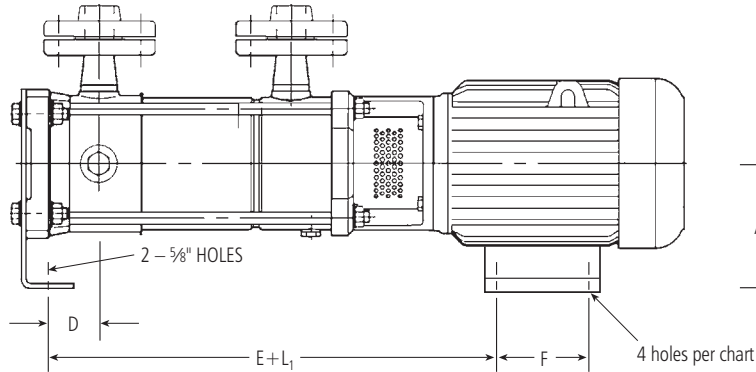

Frame	Hole Diameter
56	1 <sup>1</sup> / <sub>32</sub>
140	1 <sup>1</sup> / <sub>32</sub>
180	1 <sup>3</sup> / <sub>32</sub>
210	1 <sup>3</sup> / <sub>32</sub>
250	1 <sup>1</sup> / <sub>32</sub>
280	1 <sup>1</sup> / <sub>32</sub>

Flanges can be rotated 90° left or right.

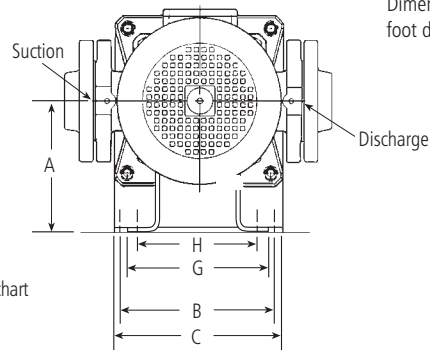
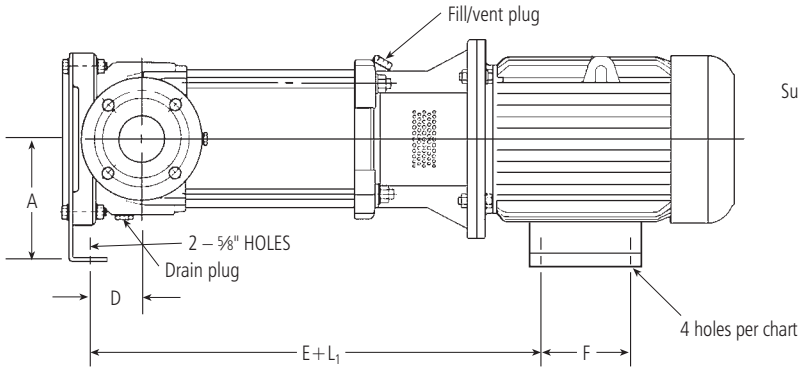

**NOTE**  
Dimensions H and G are motor foot dimensions.  
Dimensions B and C are pump foot dimensions.

Series	Motor Frame	A	B	C	D	E	F	G	H	Motor Shim Thickness	Pump Shim Thickness
1SVA	56C	4½	7	9	¾	1	3	6 <sup>7</sup> / <sub>16</sub>	4 <sup>7</sup> / <sub>8</sub>	1	—
1SVB/1SVD	56C	4½	7	9	1 <sup>1</sup> / <sub>8</sub>	1	3	6 <sup>7</sup> / <sub>16</sub>	4 <sup>7</sup> / <sub>8</sub>	1	—
	184TC	4½	7	9	1 <sup>3</sup> / <sub>8</sub>	1	5½	8 <sup>7</sup> / <sub>8</sub>	7½	—	—
1SVC	56C	4½	10½	12	1 <sup>1</sup> / <sub>8</sub>	1	3	6 <sup>7</sup> / <sub>16</sub>	4 <sup>7</sup> / <sub>8</sub>	—	—
	184TC	4½	10½	12	1 <sup>1</sup> / <sub>8</sub>	1	5½	8 <sup>7</sup> / <sub>8</sub>	7½	—	—
2SVA	56C	4½	7	9	¾	1	3	6 <sup>7</sup> / <sub>16</sub>	4 <sup>7</sup> / <sub>8</sub>	1	—
	184TC	4½	7	9	¾	1	5½	8 <sup>7</sup> / <sub>8</sub>	7½	—	—
2SVB/2SVD	56C	4½	7	9	1 <sup>3</sup> / <sub>8</sub>	1	3	6 <sup>7</sup> / <sub>16</sub>	4 <sup>7</sup> / <sub>8</sub>	1	—
	184TC	4½	7	9	1 <sup>3</sup> / <sub>8</sub>	1	5½	8 <sup>7</sup> / <sub>8</sub>	7½	—	—
2SVC	56C	4½	10½	12	1 <sup>1</sup> / <sub>8</sub>	1	3	6 <sup>7</sup> / <sub>16</sub>	4 <sup>7</sup> / <sub>8</sub>	—	—
	184TC	4½	10½	12	1 <sup>1</sup> / <sub>8</sub>	1	5½	8 <sup>7</sup> / <sub>8</sub>	7½	—	—
3SVA	56C	3½	9 <sup>7</sup> / <sub>8</sub>	10½	1 <sup>1</sup> / <sub>8</sub>	1 <sup>1</sup> / <sub>16</sub>	3	6 <sup>7</sup> / <sub>16</sub>	4 <sup>7</sup> / <sub>8</sub>	—	—
	184TC	4½	9 <sup>7</sup> / <sub>8</sub>	10½	1 <sup>1</sup> / <sub>8</sub>	1 <sup>1</sup> / <sub>16</sub>	5½	8 <sup>7</sup> / <sub>8</sub>	7½	—	—
3SVB/3SVD	56C	6¼	9 <sup>7</sup> / <sub>8</sub>	10½	2	1 <sup>1</sup> / <sub>16</sub>	3	6 <sup>7</sup> / <sub>16</sub>	4 <sup>7</sup> / <sub>8</sub>	2¼	—
	184TC	6¼	9 <sup>7</sup> / <sub>8</sub>	10½	2	1 <sup>1</sup> / <sub>16</sub>	5½	8 <sup>7</sup> / <sub>8</sub>	7½	1¾	—
	213TC	6¼	9 <sup>7</sup> / <sub>8</sub>	10½	2	2 <sup>1</sup> / <sub>16</sub>	5½	9½	8½	1	—
	215TC	6¼	9 <sup>7</sup> / <sub>8</sub>	10½	2	2 <sup>1</sup> / <sub>16</sub>	7	9½	8½	1	—
	254TC	6¼	9 <sup>7</sup> / <sub>8</sub>	10½	2	2 <sup>15</sup> / <sub>16</sub>	8¼	11¼	10	—	—
3SVC	184TCH	6¼	11 <sup>1</sup> / <sub>8</sub>	13¼	2	1 <sup>1</sup> / <sub>16</sub>	5½	8 <sup>7</sup> / <sub>8</sub>	7½	1¾	—
	213TC	6¼	11 <sup>1</sup> / <sub>8</sub>	13¼	2	2 <sup>1</sup> / <sub>16</sub>	5½	9½	8½	1	—
	215TC	6¼	11 <sup>1</sup> / <sub>8</sub>	13¼	2	2 <sup>1</sup> / <sub>16</sub>	7	9½	8½	1	—
	254TC	6¼	11 <sup>1</sup> / <sub>8</sub>	13¼	2	2 <sup>15</sup> / <sub>16</sub>	8¼	11¼	10	—	—
	184TCH	6¼	9 <sup>7</sup> / <sub>8</sub>	10½	2	1 <sup>1</sup> / <sub>16</sub>	5½	8 <sup>7</sup> / <sub>8</sub>	7½	1¾	—
4SVB/4SVD	213TC	6¼	9 <sup>7</sup> / <sub>8</sub>	10½	2	2 <sup>1</sup> / <sub>16</sub>	5½	9½	8½	1	—
	215TC	6¼	9 <sup>7</sup> / <sub>8</sub>	10½	2	2 <sup>1</sup> / <sub>16</sub>	7	9½	8½	1	—
	254TC	6¼	9 <sup>7</sup> / <sub>8</sub>	10½	2	2 <sup>15</sup> / <sub>16</sub>	8¼	11¼	10	—	—
	256TC	6¼	9 <sup>7</sup> / <sub>8</sub>	10½	2	2 <sup>15</sup> / <sub>16</sub>	10	11¼	10	—	—
	184TCH	6¼	11 <sup>1</sup> / <sub>8</sub>	13¼	2	1 <sup>1</sup> / <sub>16</sub>	5½	8 <sup>7</sup> / <sub>8</sub>	7½	1¾	—
4SVC	213TC	6¼	11 <sup>1</sup> / <sub>8</sub>	13¼	2	2 <sup>1</sup> / <sub>16</sub>	5½	9½	8½	1	—
	215TC	6¼	11 <sup>1</sup> / <sub>8</sub>	13¼	2	2 <sup>1</sup> / <sub>16</sub>	7	9½	8½	1	—
	254TC	6¼	11 <sup>1</sup> / <sub>8</sub>	13¼	2	2 <sup>15</sup> / <sub>16</sub>	8¼	11¼	10	—	—
	256TC	6¼	11 <sup>1</sup> / <sub>8</sub>	13¼	2	2 <sup>15</sup> / <sub>16</sub>	10	11¼	10	—	—
	184TCH	6¼	11 <sup>1</sup> / <sub>8</sub>	13¼	2	1 <sup>1</sup> / <sub>16</sub>	5½	8 <sup>7</sup> / <sub>8</sub>	7½	1¾	—

For all other dimensions see dimensions and weights table.  
All dimensions are in inches.

**NOTE:** L1 dimensions located on vertical version drawings.

## 33SV – 92SV Horizontal Mounting Option

- Consists of SSV pump with base mounting foot and footed motor for horizontal installations.
- Unit depicted may not show actual pump configuration. Use for mounting location only.

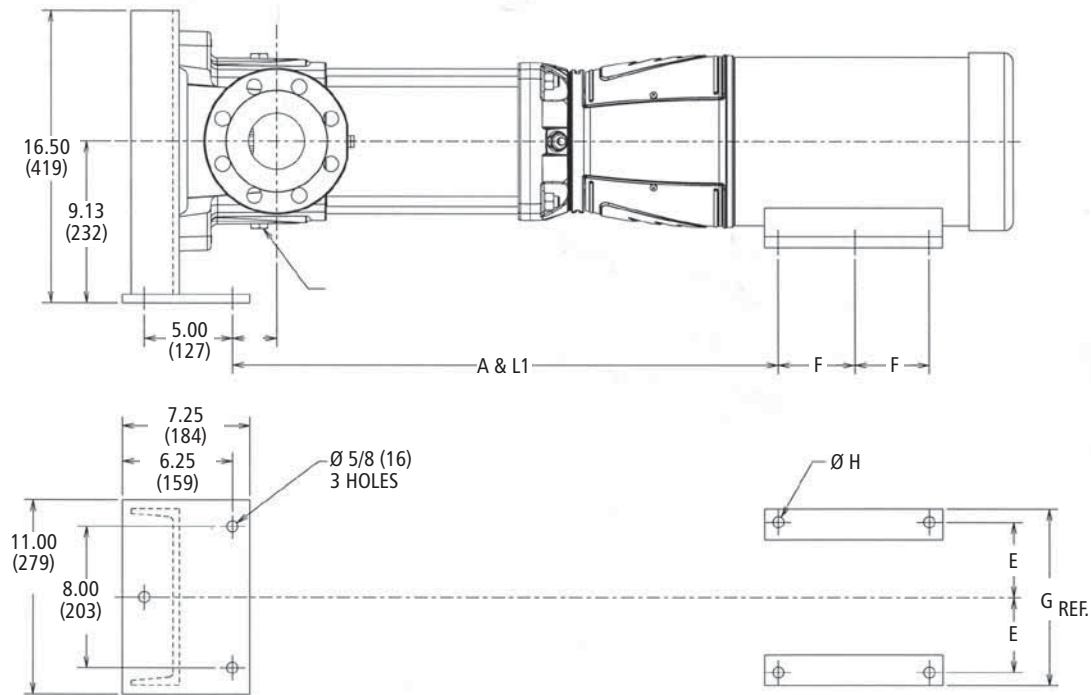

Pump	Frame	A	B	E	F	G (ref.)	H - Dia.
33SVB 33SVD	182TC	0.50	1.13	3.50	2.25	8.63	13/32
	184TC				2.75		
	213TC	1.25		4.25	2.75	9.50	
	215TC			3.50			
	254TC	1.75		5.00	4.12	11.25	17/32
	256TC			5.00			
	284TC			5.50	4.75	12.25	
	286TC			5.50			
	324TSC	2.25		6.25	5.25	16.00	21/32
	326TSC			6.00			
	364TSC	2.88		7.00	5.63	18.00	
	365TSC			6.12			
46SVB 46SVD 66SVB 66SVD 92SVB 92SVD	182TC	0.50	2.50	3.70	2.25	8.63	13/32
	184TC				2.75		
	213TC	1.25		4.25	2.75	9.50	
	215TC			3.50			
	254TC	1.75		5.00	4.12	11.25	17/32
	256TC			5.00			
	284TC			5.50	4.75	13.50	
	286TC			5.50			
	324TSC	2.25		6.25	5.25	15.25	21/32
	326TSC			6.00			
	364TSC	2.88		7.00	5.63	17.00	
	365TSC			6.12			

## Technical Data – Pump Hydraulics / Motor Sizing

### 1SV 3500 RPM

Number of Stages	Maximum HP Draw	Motor HP for use With 1.15 SF Motor	Motor HP for use With AQUAVAR (1.0 SF)	Shutoff TDH (Feet)	Shutoff TDH (Bar)	MAWP	Motor Rotation
22	6.7	7.5	7.5	1100	32.8	580 PSI (40 Bar)	CCW
20	6.1	7.5	7.5	1005	30.0		
18	5.4	5	7.5	905	27.0		
16	4.8	5	5	795	23.7	362 PSI (25 Bar)	CW
15	4.6	5	5	742	22.2		
13	4	5	5	642	19.2		
11	3.4	3	5	550	16.4		
9	2.7	3	3	445	13.3		
8	2.4	3	3	398	11.9		
7	2	2	2	350	10.4		
6	1.8	2	2	300	9.0		
5	1.5	1.5	1.5	250	7.5		
4	1.1	1	1.5	200	6.0		
3	0.9	3/4	1	142	4.2		
2	0.6	1/2	3/4	100	3.0		

### 2SV 3500 RPM

Number of Stages	Maximum HP Draw	Motor HP for use With 1.15 SF Motor	Motor HP for use With AQUAVAR (1.0 SF)	Shutoff TDH (Feet)	Shutoff TDH (Bar)	MAWP	Motor Rotation
22	7.7	7.5	NA	950	28.4	580 PSI (40 Bar)	CCW
20	6.8	7.5	7.5	860	25.7		
18	6.2	7.5	7.5	760	22.7		
16	5.3	5	7.5	726	21.7	362 PSI (25 Bar)	CW
15	4.9	5	5	680	20.3		
13	4.6	5	5	595	17.8		
11	4	5	5	500	14.9		
9	3.3	3	5	407	12.2		
8	2.9	3	3	360	10.7		
7	2.4	3	3	315	9.4		
6	2.1	2	3	270	8.1		
5	1.8	2	2	222	6.6		
4	1.5	1.5	1.5	175	5.2		
3	1.1	1	1.5	137	4.1		
2	0.7	3/4	1	92	2.7		

### 3SV 3500 RPM

Number of Stages	Maximum HP Draw	Motor HP for use With 1.15 SF Motor	Motor HP for use With AQUAVAR (1.0 SF)	Shutoff TDH (Feet)	Shutoff TDH (Bar)	MAWP	Motor Rotation
16	17.6	20	20	1010	30.2	580 PSI (40 Bar)	CCW
14	15	15	15	894	26.7		
13	14	15	15	830	24.8		
12	12.8	15	15	760	22.7	362 PSI (25 Bar)	CW
11	11.5	10	15	700	20.9		
10	10.7	10	15	640	19.1		
9	9.7	10	10	575	17.2		
8	8.5	7.5	10	505	15.1		
7	7.5	7.5	7.5	450	13.4		
6	6.5	7.5	7.5	380	11.3		
5	5.4	5	7.5	320	9.6		
4	4.3	5	5	250	7.5		
3	3.3	3	5	190	5.7		
2	2.2	2	3	128	3.8		

## Technical Data – Pump Hydraulics / Motor Sizing

### 4SV 3500 RPM

Number of Stages	Maximum HP Draw	Motor HP for use With 1.15 SF Motor	Motor HP for use With AQUAVAR (1.0 SF)	Shutoff TDH (Feet)	Shutoff TDH (Bar)	MAWP	Motor Rotation
12	26.4	25	NA	930	27.8	580 PSI (40 Bar)	CCW
10	21.6	20	25	780	23.3	362 PSI (25 Bar)	CW
9	19.2	20	20	700	20.9		
8	16.9	15	20	620	18.5		
7	14.9	15	15	540	16.1		
6	12.9	15	15	460	13.7		
5	10.7	10	15	390	11.6		
4	8.6	7.5	10	305	9.1		
3	6.3	7.5	7.5	228	6.8		
2	4.3	5	5	150	4.5		

### 33SV 3500 RPM

# of Impellers / # reduced Diameter	Maximum HP Draw	Motor HP for use with 1.15 SF Motor	Motor HP for use with Aquavar (1.0 SF)	Shutoff TDH (Feet)	Shutoff TDH (Bar)	Casing / Sleeve Pressure rating (Standard Assy.)	Stages requiring Thrust Balancing Piston	Pump Flange Rating		
10	54.3	50	60	1125	34	40 Bar (580 PSI)	Thrust Piston Required	Class 250 / 300		
10/2	52.8			1096	33					
10/1	51.3			1066	32					
9	48.8			50	50				1012	30
9/1	47.4								983	29
9/2	45.9								954	28
8	43.4	900	27							
8/1	41/9	871	26							
8/2	40.5	842	25							
7	38	40	40	787	23				25 Bar (362 PSI) ①	Class 125 / 150
7/1	36.5			758	23					
7/2	35			729	22					
6	32.6			30	30	576	20			
6/1	31.1					646	19			
6/2	29.6					617	18			
5	27.1	25	25			562	17			
5/1	25.7					533	16			
5/2	24.2					504	15			
4	21.7			20	20	450	13			
4/1	20.2					421	13			
4/2	18.8					392	12			
3	16.3	15	15			337	10			
3/1	14.7					310	9			
3/2	13.2					281	8			
2	10.9			10	10	225	7			
2/1	9.4					196	6			
2/2	7.9					167	5			
1	5.4	5	5			113	3			
1/1	4					84	3			

① Pump assembly may be modified for 40 bar (580 psi) application – contact factory.

## Technical Data – Pump Hydraulics / Motor Sizing

### 46SV 3500 RPM

# of Impellers / # reduced Diameter	Maximum HP Draw	Motor HP for use with 1.15 SF Motor	Motor HP for use with Aquavar (1.0 SF)	Shutoff TDH (Feet)	Shutoff TDH (Bar)	Casing / Sleeve Pressure rating (Standard Assy.)	Stages requiring Thrust Balancing Piston	Pump Flange Rating
10/2	77.8	75	75	1210	36.1	40 Bar (580 PSI)	Thrust Piston Required	Class 250 / 300
9	73.2			1137	33.9			
9/1	71.5			1111	33.2			
9/2	69.7			1085	32.4			
8	65	60	60	1010	30.2			
8/1	63.3			984	29.4			
8/2	61.6			959	28.6			
7	56.9	50	50	884	26.4			
7/1	55.2			858	25.6			
7/2	53.4			832	24.8			
6	48.8			758	22.6			
6/1	47.1	40	40	732	21.9			
6/2	45.3			706	21.1			
5	40.7			632	18.9			
5/1	38.9			605	18.1			
5/2	37.2	30	30	580	17.3			
4	32.5			505	15.1			
4/1	30.8			479	14.3			
4/2	29			453	13.5			
3	24.4	25	25	379	11.3	25 Bar (362 PSI) ①		Class 125 / 150
3/1	22.7	20	20	353	10.5			
3/2	20.9			327	9.8			
2	16.3	15	15	253	7.6			
2/1	14/5			226	6.7			
2/2	12.8			200	6.0			
1	8.5			10	10			
1/1	6.7	7.5	7.5	102	3.0			

### 66SV 3500 RPM

# of Impellers / # reduced Diameter	Maximum HP Draw	Motor HP for use with 1.15 SF Motor	Motor HP for use with Aquavar (1.0 SF)	Shutoff TDH (Feet)	Shutoff TDH (Bar)	Casing / Sleeve Pressure rating (Standard Assy.)	Stages requiring Thrust Balancing Piston	Pump Flange Rating
6	73.2	75	75	850	25.4	40 Bar (580 PSI)	Thrust Piston Required	Class 250 / 300
6/1	70.2			822	24.5			
6/2	67.2			796	23.8			
5	61	60	60	707	21.1	25 Bar (362 PSI) ①		Class 125 / 150
5/1	58			681	20.3			
5/2	55			655	19.6			
4	48.8	50	50	566	16.9			
4/1	45.8			540	16.1			
4/2	42.8			513	15.3			
3	36.6	40	40	424	12.7			
3/1	33.6			398	11.9			
3/2	30.6			372	11.1			
2	24.4	25	25	283	8.4			
2/1	21.4			257	7.7			
2/2	18.4			230	6.9			
1	12.2	20	20	142	4.2			
1/1	9.2			10	10	115	3.4	

① Pump assembly may be modified for 40 bar (580 psi) application – contact factory.

## Technical Data – Pump Hydraulics / Motor Sizing

### 92SV 3500 RPM

# of Impellers / # reduced Diameter	Maximum HP Draw	Motor HP for use with 1.15 SF Motor	Motor HP for use with Aquavar (1.0 SF)	Shutoff TDH (Feet)	Shutoff TDH (Bar)	Casing / Sleeve Pressure rating (Standard Assy.)	Stages requiring Thrust Balancing Piston	Pump Flange Rating
5/1	73.8	75	75	732	21.9	25 Bar (362 PSI) ①	Thrust Piston Required	Class 250 / 300
5/2	70.3			707	21.1			
4	61.9			605	18.1			
4/1	58.3	60	580	17.3				
4/2	54.8		556	16.6				
3	46.5	50	50	454	13.6			
3/1	42.9	40	40	429	12.8			
3/2	39.4			405	12.1			
2	31	30	30	305	9.1			
2/1	27.4			278	8.3			
2/2	23.4			253	7.6			
1	15.5	15	15	151	4.5			
1/1	12			127	3.8			

① Pump assembly may be modified for 40 bar (580 psi) application – contact factory.

## Technical Data – Pump Hydraulics / Motor Sizing

### 1SV 2900 RPM

Number of Stages	Maximum HP Draw	Motor HP	Shutoff TDH (Meters)	Shutoff TDH (Bar)	MAWP	Motor Rotation
24	3.72	5	258	25.0	362 PSI (25 Bar)	CW
22	3.41	3	237	23.2		
20	3.10		217	21.3		
18	2.79		194	19.0		
16	2.48		172	16.8		
14	2.17		2	152		
12	1.86	130		12.7		
11	1.71	1½		118		
9	1.40		97	9.5		
8	1.24		87	8.5		
7	1.09		75	7.3		
6	0.93	¾	65	6.4		
5	0.78		54	5.3		
4	0.62	½	43	4.2		
3	0.47		33	3.2		
2	0.31		23	2.3		

### 2SV 2900 RPM

Number of Stages	Maximum HP Draw	Motor HP	Shutoff TDH (Meters)	Shutoff TDH (Bar)	MAWP	Motor Rotation
24	4.80	5	242	23.7	362 PSI (25 Bar)	CW
22	4.40		222	21.7		
20	4.00		202	19.8		
18	3.60	3	182	17.8		
16	3.20		162	15.9		
14	2.80		142	13.9		
13	2.60		132	12.9		
11	2.20	2	112	11.0		
9	1.80		92	9.0		
8	1.60	1½	82	8.0		
7	1.40		72	7.1		
6	1.20	1	62	6.1		
5	1.00		52	5.1		
4	0.80		¾	42		
3	0.60	32		3.1		
2	0.40	½	20	2.0		

### 3SV 2900 RPM

Number of Stages	Maximum HP Draw	Motor HP	Shutoff TDH (Meters)	Shutoff TDH (Bar)	MAWP	Motor Rotation
16	9.6	10	220	21.6	362 PSI (25 Bar)	CW
14	8.4	7½	192	18.8		
12	7.2		164	16.1		
11	6.6		150	14.7		
9	5.4	5	124	12.1		
8	4.8		110	10.8		
6	3.6		82	8.0		
5	3	3	68	6.7		
4	2.4	2	55	5.4		
3	1.8	1½	41	4.0		
2	1.2		28	2.7		

#### NOTES:

½ – 1 HP = 1.25 S.F. @ 50 Hz.

1½ – 75 HP = 1.15 S.F. @ 50 Hz.

## Technical Data – Pump Hydraulics / Motor Sizing

### 4SV 2900 RPM

Number of Stages	Maximum HP Draw	Motor HP	Shutoff TDH (Meters)	Shutoff TDH (Bar)	MAWP	Motor Rotation
15	18	20	258	25.0	362 PSI (25 Bar)	CW
14	16.8	15	242	23.7		
12	14.4		208	20.4		
10	12		173	16.9		
8	9.6	10	138	13.5		
7	8.4	7½	122	12.0		
6	7.2		104	10.2		
5	6		86	8.4		
4	4.8		5	68		
3	3.6	3	53	5.2		
2	2.3	2	35	3.4		

### 33SV 2900 RPM

# of Impellers / # reduced Diameter	Maximum HP Draw	Motor HP for use with 1.15 SF Motor (@ 50 Hz)	Shutoff TDH (Feet)	Shutoff TDH (Bar)	Casing / Sleeve Pressure rating (Standard Assy.)	Stages requiring Thrust Balancing Piston	Pump Flange Rating	
10	32	30	750	22.4	25 Bar (362 PSI) ①	Thrust Piston Required	Class 250 / 300	
10/1	30.5		731	21.8				
10/2	29		712	21.3				
9	28.8	25	675	20.2				
9/1	27.3		656	19.6				
9/2	25.8		637	19				
8	25.6		600	17.9				
8/1	24.1	20	582	17.4				Class 125 / 150
8/2	22.6		562	16.8				
7	22.4		525	15.7				
7/1	20.9		506	15.1				
7/2	19.4		487	14.5				
6	19.2		450	13.4				
6/1	17.7	15	431	12.9				
6/2	16.2		412	12.3				
5	16		376	11.2				
5/1	14.5		356	10.6				
5/2	13		337	10.1				
4	12.8	10	300	9				
4/1	11.3		281	8.4				
4/2	9.8		262	7.8				
3	9.6		225	6.7				
3/1	8.1	7.5	206	6.2				
3/2	6.6		187	5.6				
2	6.4		150	4.5				
2/1	4.9	5	131	3.9				
2/2	3.5		111	3.3				
1	3.2	3	75	2.2				
1/1	1.7	2	56	1.7				

① Pump assembly may be modified for 40 bar (580 psi) application – contact factory.

## Technical Data – Pump Hydraulics / Motor Sizing

### 46SV 2900 RPM

# of Impellers / # reduced Diameter	Maximum HP Draw	Motor HP for use with 1.15 SF Motor (@ 50 Hz)	Shutoff TDH (Feet)	Shutoff TDH (Bar)	Casing / Sleeve Pressure rating (Standard Assy.)	Stages requiring Thrust Balancing Piston	Pump Flange Rating
10	45.9	40	256	7.6	25 Bar (362 PSI) ①		Class 125 / 150
10/1	44.1		251	7.5			
10/2	42.4		246	7.3			
9	41.3		231	6.9			
9/1	39.6		225	6.7			
9/2	37.8		220	6.6			
8	36.7		205	6.1			
8/1	35.0	30	200	6.0			
8/2	33.3		194	5.8			
7	32.0		180	5.4			
7/1	30.3	25	174	5.2			
7/2	28.6		169	5.0			
6	27.5		154	4.6			
6/1	25.7	20	148	4.4			
6/2	24.0		143	4.3			
5	22.9		128	3.8			
5/1	21.2	15	123	3.7			
5/2	19.4		117	3.5			
4	18.4		103	3.1			
4/1	16.6	10	97	2.9			
4/2	14.9		92	2.7			
3	13.8		77	2.3			
3/1	12.1	5	72	2.1			
3/2	10.3		66	2.0			
2	9.1		51	1.5			
2/1	7.5	7.5	46	1.4			
2/2	5.6	5	41	1.2			
1	4.6		26	0.8			
1/1	3.8		23	0.7			

① Pump assembly may be modified for 40 bar (580 psi) application – contact factory.

## Technical Data – Pump Hydraulics / Motor Sizing

### 66SV 2900 RPM

# of Impellers / # reduced Diameter	Maximum HP Draw	Motor HP for use with 1.15 SF Motor (@ 50 Hz)	Shutoff TDH (Feet)	Shutoff TDH (Bar)	Casing / Sleeve Pressure rating (Standard Assy.)	Stages requiring Thrust Balancing Piston	Pump Flange Rating
6	41	40	564	16.8	25 Bar (362 PSI) ①	Thrust Piston Required	Class 250 / 300
6/1	39.1		545	16.3			
6/2	37.3		528	15.8			
5	34	30	469	14.0			
5/1	32.3		452	13.5			
5/2	30.5		434	13.0			
4	27.1	25	376	11.2		Class 125 / 150	
4/1	25.3		358	10.7			
4/2	23.7		340	10.2			
3	20.5	20	282	8.4			
3/1	18.7		264	7.9			
3/2	16.9		246	7.3			
2	13.6	15	188	5.6			
2/1	11.9		170	5.1			
2/2	10.1		152	4.5			
1	6.8	10	94	2.8			
1/1	5.1	5	76	2.3			

### 92SV 2900 RPM

# of Impellers / # reduced Diameter	Maximum HP Draw	Motor HP for use with 1.15 SF Motor (@ 50 Hz)	Shutoff TDH (Feet)	Shutoff TDH (Bar)	Casing / Sleeve Pressure rating (Standard Assy.)	Stages requiring Thrust Balancing Piston	Pump Flange Rating
6	53.3	50	610	18.21	25 Bar (362 PSI) ①	Thrust Piston Required	Class 250 / 300
6/1	51		594	17.73			
6/2	48.7		577	17.23			
5	44.4	40	509	15.20			
5/1	42.1		492	14.69			
5/2	40		475	14.18			
4	35.5	30	407	12.15		Class 125 / 150	
4/1	33.2		390	11.64			
4/2	31		374	11.17			
3	26.6	25	305	9.11			
3/1	24.3		289	8.63			
3/2	22		272	8.12			
2	17.8	20	204	6.09			
2/1	15.5		187	5.58			
2/2	13.1		171	5.11			
1	9	10	102	3.05			
1/1	6.8	7.5	85	2.54			

① Pump assembly may be modified for 40 bar (580 psi) application – contact factory.

### Maximum Inlet Pressure

The following table shows the maximum permissible inlet pressure. However, the actual inlet pressure + pressure against a closed valve must always be lower than the maximum permissible operating pressure.

(Refer to pressure/temperature curves on page 13 to verify MAWP of pump)

Pump	Number of Stages	Max. Inlet Pressure
1SV	2-16 Stages	250 psi (17 bar)
	17-22 Stages	
2SV	2-25 Stages	
	16-22 Stages	
3SV	2-13 Stages	
	14-16 Stages	
4SV	2-10 Stages	
	11-12 Stages	
33SV	1-10 Stages	
46SV	1-10 Stages	
66SV	1-6 Stages	
92SV	1-6 Stages	

## Technical Data – Water Property Chart

Temp °F	Temp °C	Specific Volume (Cubic ft/lb)	Specific Gravity			Weight (lb/cubic ft)	Vapor Pressure (psi Abs)
			@ 39.2°F	@ 60°F	@ 68°F		
32	0.0	0.01602	1.000	1.001	1.002	62.42	0.088
35	1.7	0.01602	1.000	1.001	1.002	62.42	0.100
40	4.4	0.01602	1.000	1.001	1.002	62.42	0.122
50	10.0	0.01603	0.999	1.001	1.002	62.38	0.178
60	15.6	0.01604	0.999	1.000	1.001	62.34	0.256
70	21.1	0.01606	0.998	0.999	1.000	62.27	0.363
80	26.7	0.01608	0.996	0.998	0.999	62.19	0.507
90	32.2	0.0161	0.995	0.996	0.997	62.11	0.698
100	37.8	0.01613	0.993	0.994	0.995	62.00	0.949
120	48.9	0.0162	0.989	0.990	0.991	61.73	1.692
140	60.0	0.01629	0.983	0.985	0.986	61.39	2.889
160	71.1	0.01639	0.977	0.979	0.979	61.01	4.741
180	82.2	0.01651	0.970	0.972	0.973	60.57	7.510
200	93.3	0.01663	0.963	0.964	0.966	60.13	11.526
212	100.0	0.01672	0.958	0.959	0.960	59.81	14.696
220	104.4	0.01677	0.955	0.956	0.957	59.63	17.186
240	115.6	0.01692	0.947	0.948	0.949	59.10	24.97
260	126.7	0.01709	0.938	0.939	0.940	58.51	35.43
280	137.8	0.01726	0.928	0.929	0.930	58.00	49.20
300	148.9	0.01745	0.918	0.919	0.920	57.31	67.01
320	160.0	0.01756	0.908	0.909	0.910	56.66	89.66
340	171.1	0.01787	0.896	0.898	0.899	55.96	118.01
360	182.2	0.01811	0.885	0.886	0.887	55.22	153.04
380	193.3	0.01836	0.873	0.874	0.875	54.47	195.77
400	204.4	0.01864	0.859	0.860	0.862	53.65	247.31
420	215.6	0.01894	0.846	0.847	0.848	52.80	308.83
440	226.7	0.01926	0.832	0.833	0.834	51.92	381.59
460	237.8	0.0196	0.817	0.818	0.819	51.02	466.9
480	248.9	0.02	0.801	0.802	0.803	50.00	566.1
500	260.0	0.0204	0.785	0.786	0.787	49.02	680.8
520	271.1	0.0209	0.765	0.766	0.767	47.85	812.4
540	282.2	0.0215	0.746	0.747	0.748	46.51	962.5
560	293.3	0.0221	0.726	0.727	0.728	45.30	1133.1
580	304.4	0.0228	0.703	0.704	0.704	43.90	1325.8
600	315.6	0.0236	0.678	0.679	0.680	42.30	1542.9
620	326.7	0.0247	0.649	0.650	0.650	40.50	1786.6
640	337.8	0.026	0.617	0.618	0.618	38.50	2059.7
660	348.9	0.0278	0.577	0.577	0.578	36.00	2365.4
680	360.0	0.0305	0.525	0.526	0.527	32.80	2708.1
700	371.1	0.0369	0.434	0.435	0.435	27.10	3093.7

## NPSH

The minimum operating values that can be reached at the pump suction end are limited by the onset of cavitation.

Cavitation is the formation of vapor-filled cavities within liquids where the pressure is locally reduced to a critical value, or where the local pressure is equal to, or just below the vapor pressure of the liquid.

The vapor-filled cavities flow with the current and when they reach a higher pressure the vapor contained in the cavities condenses. The cavities collide, generating pressure waves that are transmitted to the walls. These, being subjected to stress cycles, gradually become deformed and yield due to fatigue. This phenomenon, characterized by a metallic noise produced by the hammering on the pipe walls, is called incipient cavitation.

The damage caused by cavitation may be magnified by electrochemical corrosion and a local rise in temperature due to the plastic deformation of the walls. The materials that offer the highest resistance to heat and corrosion are alloy steels, especially austenitic steel. The conditions that trigger cavitation may be assessed by calculating the total net suction head, referred to in technical literature with the acronym NPSH (Net Positive Suction Head).

The NPSH represents the total energy (expressed in feet) of the liquid measured at suction under conditions of incipient cavitation, excluding the vapor pressure (expressed in feet) that the liquid has at the pump inlet.

To find the static height ( $h_z$ ) at which to install the machine under safe conditions, the following formula must be verified:

$$h_p + h_z \geq (\text{NPSHr} + 2 \text{ ft}) + h_f + h_{pv}$$

where:

$h_p$  is the absolute pressure applied to the free liquid surface in the suction tank, expressed in feet of liquid;  $h_p$  is the quotient between the barometric pressure and the specific weight of the liquid.

$h_z$  is the suction lift between the pump axis and the free liquid surface in the suction tank, expressed in feet;  $h_z$  is negative when the liquid level is lower than the pump axis.

$h_f$  is the flow resistance in the suction line and its accessories, such as: fittings, foot valve, gate valve, elbows, etc.

$h_{pv}$  is the vapor pressure of the liquid at the operating temperature, expressed in feet of the liquid.  $h_{pv}$  is the quotient between the  $P_v$  vapor pressure and the liquid's specific weight.

0.5 is the safety factor.

The maximum possible suction head for installation depends on the value of the atmospheric pressure (i.e. the elevation above sea level at which the pump is installed) and the temperature of the liquid.

To help the user, with reference to water temperature (40°F) and to the elevation above sea level, the following tables show the drop in hydraulic pressure head in relation to the elevation above sea level, and the suction loss in relation to temperature.

Water Temperature (°F)	68	104	140	176	194	230	248
Suction Loss (ft)	-.7	2.3	6.6	16.4	24.3	50.5	70.5

Elevation Above Sea Level (ft)	1600	3300	4900	6500	8200	9800
Suction Loss (ft)	1.8	3.6	5.4	7.2	9.0	10.8

To reduce it to a minimum, especially in cases of high suction head (over 13 – 16 feet) or within the operating limits with high flow rates, we recommend using a suction line having a larger diameter than that of the pump's suction port. It is always a good idea to position the pump as close as possible to the liquid to be pumped.

## Technical Data – Compatibility Chart for Materials in Contact with Most Commonly Used Liquids

Liquid	Concentration (%)	Temperature Min/Max °F	Specific Weight (lb/in <sup>3</sup> )	SV 2, 4, 8, 16		SV 33, 46, 66, 92		Recommended Seal	Elastomers
				304	316	Cl/316	316		
Water	100	23/248		•	•	•	•	Q <sub>1</sub> BEGG	E
Deionized, demineralized or distilled water	100	-13/230		•	•	•	•	Q <sub>1</sub> BEGG	E
Water and oil emulsion	any	23/194		•	•	•	•	Q <sub>1</sub> BVGG	V
Acetic acid (•)	80	14/158	.038	•	•	•	•	Q <sub>1</sub> BEGG	E
Citric acid	5	14/158	.056	•	•	•	•	Q <sub>1</sub> BEGG	E
Hydrochloric acid	2	23/77	.043		•		•	Q <sub>1</sub> Q <sub>1</sub> VGG	V
Phosphoric acid	10	23/86	.048		•		•	Q <sub>1</sub> BEGG	E
Nitric acid (•)	50	23/86	.053	•	•	•	•	Q <sub>1</sub> Q <sub>1</sub> VGG	V
Sulphuric acid (•)	2	14/77	.066		•		•	Q <sub>1</sub> BVGG	V
Tannic acid	20	32/122			•		•	Q <sub>1</sub> BEGG	E
Tartaric acid	50	14/77	.063	•	•	•	•	Q <sub>1</sub> Q <sub>1</sub> VGG	V
Uric acid	80	14/176	.068	•	•	•	•	Q <sub>1</sub> BEGG	E
Benzoic acid	70	32/158	.047	•	•	•	•	Q <sub>1</sub> BVGG	V
Boric acid	Saturated	14/194	.052	•	•	•	•	Q <sub>1</sub> Q <sub>1</sub> VGG	V
Formic acid (•)	5	5/77	.044	•	•	•	•	Q <sub>1</sub> BEGG	E
Ethyl alcohol (•)	100	23/104	.029	•	•	•	•	Q <sub>1</sub> BEGG	E
Methyl alcohol (•)	100	23/104	.029	•	•	•	•	Q <sub>1</sub> BEGG	E
Propyl alcohol (•)	100	23/176	.029	•	•	•	•	Q <sub>1</sub> BEGG	E
Butyl alcohol	100	23/176	.030	•	•	•	•	Q <sub>1</sub> BVGG	V
Denatured alcohol (•)	100	23/158	.030	•	•	•	•	Q <sub>1</sub> BEGG	E
Ammonia in water (•)	25	-4/122	.038	•	•	•	•	Q <sub>1</sub> BEGG	E
Chloroform		14/86	.053	•	•	•	•	Q <sub>1</sub> BVGG	V
Caustic soda	25	32/158	.077	•	•	•	•	Q <sub>1</sub> Q <sub>1</sub> EGG	E
Water, detergents, mineral oils mixture		23/176		•	•	•	•	Q <sub>1</sub> Q <sub>1</sub> VGG	V
Cleaning products		23/212		•	•	•	•	Q <sub>1</sub> Q <sub>1</sub> VGG	V
Diesel oil (•)	100	32/176	.033	•	•	•	•	Q <sub>1</sub> BVGG	V
Kerosene (•)	100	32/176		•	•	•	•	Q <sub>1</sub> BVGG	V
Fuel oil (•)		32/194	.027	•	•	•	•	Q <sub>1</sub> BVGG	V
Glycerine	100	68/194	.046	•	•	•	•	Q <sub>1</sub> BEGG	E
Sodium Hypochlorite	1	14/77			•		•	Q <sub>1</sub> Q <sub>1</sub> VGG	V
Phosphates/polyphosphates		23/194			•		•	Q <sub>1</sub> Q <sub>1</sub> VGG	V
Sodium nitrate	Saturated	14/176	.081	•	•	•	•	Q <sub>1</sub> BEGG	E
Cutting fluid	100	23/230	.033	•	•	•	•	Q <sub>1</sub> BVGG	V
Peanut oil (•)	100	23/230	.034	•	•	•	•	Q <sub>1</sub> BEGG	E
Colza oil (•)	100	23/230	.034	•	•	•	•	Q <sub>1</sub> BEGG	E
Linseed oil (•)	100	23/230	.034	•	•	•	•	Q <sub>1</sub> BEGG	E
Coconut oil (•)	100	-4/194	.033	•	•	•	•	Q <sub>1</sub> BEGG	E
Soybean oil (•)	100	32/194		•	•	•	•	Q <sub>1</sub> BEGG	E
Diathermic oil	100	23/230	.033	•	•	•	•	Q <sub>1</sub> BVGG	V
Hydraulic oil	100	23/230		•	•	•	•	Q <sub>1</sub> BVGG	V
Mineral oil	100	23/230	.034	•	•	•	•	Q <sub>1</sub> BVGG	V
Sodium sulfate	15	14/104	.094	•	•	•	•	Q <sub>1</sub> Q <sub>1</sub> EGG	E
Aluminum sulfate	30	23/122	.097		•		•	Q <sub>1</sub> Q <sub>1</sub> EGG	E
Ammonium sulfate	10	14/140	.064		•		•	Q <sub>1</sub> Q <sub>1</sub> EGG	E
Iron sulfate	10	23/86	.076		•		•	Q <sub>1</sub> BEGG	E
Copper sulfate	20	32/86	.082		•		•	Q <sub>1</sub> Q <sub>1</sub> VGG	V
Trichloroethylene		14/104	.053	•	•	•	•	Q <sub>1</sub> BVGG	V
Perchloroethylene		14/86	.057	•	•	•	•	Q <sub>1</sub> BVGG	V

### Legend

- Q<sub>1</sub> = Silicon carbide
- B = Impregnated carbon
- E = EPDM
- V = Viton
- G = AISI 316 (spring, metal components)

(•) A special version may be necessary for this fluid. For additional information, please contact our sales network.

---

**NOTES**

---

---

**NOTES**

---

Goulds Pumps is a brand of ITT Water Technology, Inc. – a subsidiary of ITT Industries, Inc.

Goulds Pumps, G&L Pumps, Aquavar and the ITT Engineered Blocks Symbol are registered trademarks and tradenames of ITT Industries.